

REVISIONS			
REV.	DESCRIPTION	DATE	APPROVED
A	INITIAL RELEASE	10/31/08	
B	TUBES CHANGED	2/4/09	

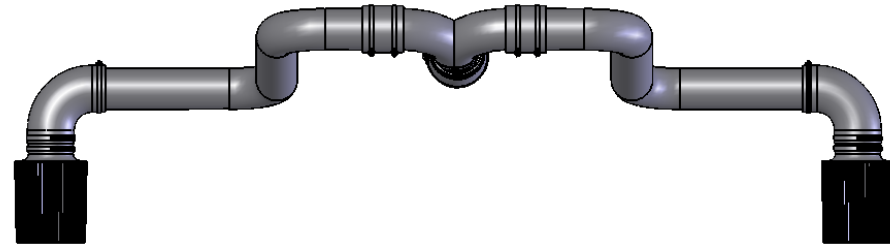
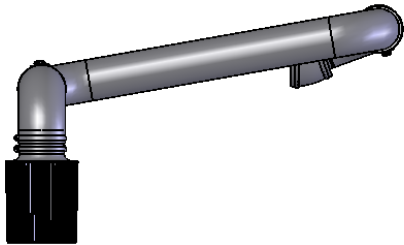
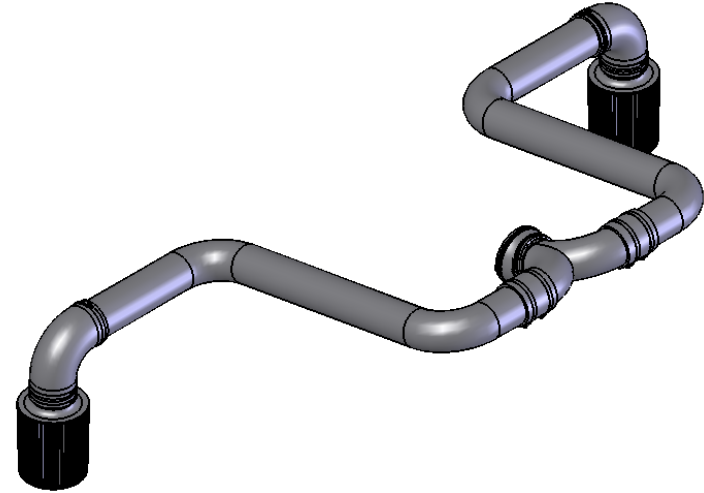
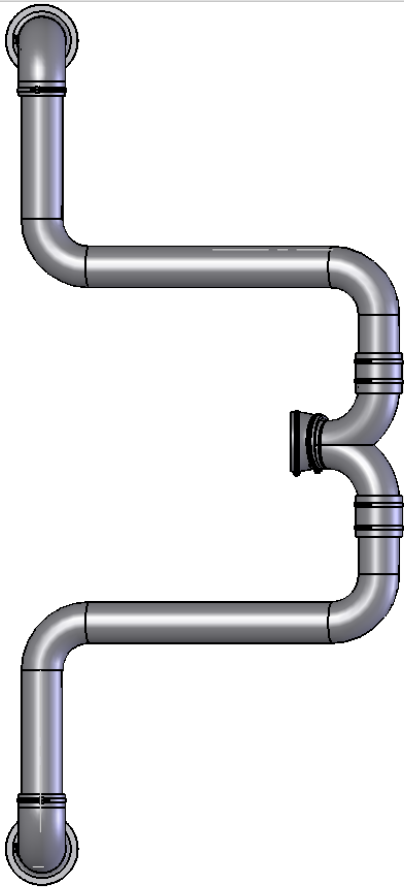

PROPRIETARY AND CONFIDENTIAL
 THE INFORMATION CONTAINED IN THIS DRAWING IS THE SOLE PROPERTY OF FACTORY FIVE RACING, INC. ANY REPRODUCTION IN PART OR AS A WHOLE WITHOUT THE WRITTEN PERMISSION OF FACTORY FIVE RACING, INC. IS PROHIBITED.

UNLESS OTHERWISE SPECIFIED:

DIMENSIONS ARE IN INCHES
 TOLERANCES:
 TWO PLACE DECIMAL ±0.01
 THREE PLACE DECIMAL ±0.005
 FOUR PLACE DECIMAL ±0.001

MATERIAL

FINISH

PRINTED
 8/14/2009

USED ON	
APPLICATION	

	NAME	DATE
DRAWN	JJ	10/28/08
CHECKED		
ENG APPR.		
MFG APPR.		
Q.A.		
COMMENTS:		



Factory Five Racing, Inc.

TITLE:

GTM COLD AIR INTAKE

SIZE
A

DWG. NO.

26054 - COLD AIR INTAKE

REV
B

SCALE: 1:14

WEIGHT:

SHEET 1 OF 2

ITEM NO.	PART NUMBER	DESCRIPTION	QTY.
1	26057 - REDUCER BEND	REDUCER ELBOW	1
2	26067 - WELDED Y TUBE	WELDED INTAKE TUBE	1
3	26060 - STRAIGHT CONNECTOR	3" STRAIGHT CONNECTOR	2
4	26066 - BENT TUBE	BENT INTAKE TUBE	2
5	26063 - 90 BEND ADAPTER	3" ELBOW	2
6	26068 - STRAIGHT TUBE	STRAIGHT TUBE	2
7	26055 - AIR FILTER		2
8	HARHS56	#56 Hose Clamp	8
9	HARHS80	#80 Hose Clamp	1
10	HARHS72	#72 Hose Clamp	1

REVISIONS			
REV.	DESCRIPTION	DATE	APPROVED
A	INITIAL RELEASE	10/31/08	
B	TUBES CHANGED	2/4/09	

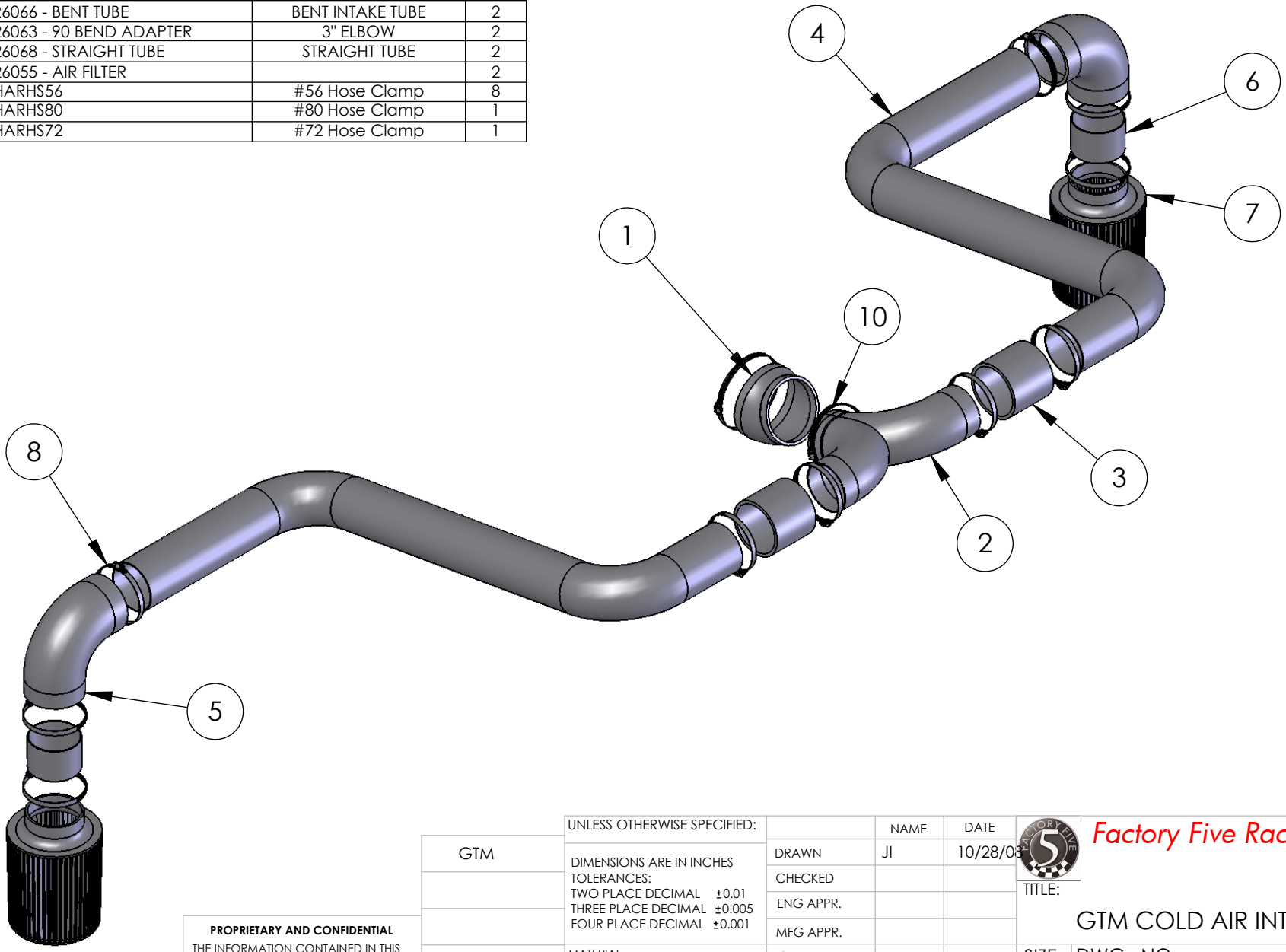

PROPRIETARY AND CONFIDENTIAL
 THE INFORMATION CONTAINED IN THIS DRAWING IS THE SOLE PROPERTY OF FACTORY FIVE RACING, INC. ANY REPRODUCTION IN PART OR AS A WHOLE WITHOUT THE WRITTEN PERMISSION OF FACTORY FIVE RACING, INC. IS PROHIBITED.

UNLESS OTHERWISE SPECIFIED:		NAME	DATE
GTM	DIMENSIONS ARE IN INCHES	DRAWN	JI 10/28/08
	TOLERANCES:	CHECKED	
	TWO PLACE DECIMAL ±0.01	ENG APPR.	
	THREE PLACE DECIMAL ±0.005	MFG APPR.	
	FOUR PLACE DECIMAL ±0.001	Q.A.	
	MATERIAL	COMMENTS:	
	FINISH	LOOSLY FIT ALL TUBES AND HOSES BEFORE TIGHTENING HOSE CLAMPS	
USED ON	PRINTED		
APPLICATION	8/14/2009		

5 Factory Five Racing, Inc.
 TITLE: GTM COLD AIR INTAKE
 SIZE DWG. NO. REV
A 26054 - COLD AIR INTAKE **B**
 SCALE: 1:8 WEIGHT: SHEET 2 OF 2