

Part Number: 33871

Revision:T

Effective Date: 11/30/16

By: J. INGERSLEV

Document Type (indicate):

◦ Bill of Material

◦ Drawing (may be attached)

◦ Specification

• **Assembly Instructions**

◦ Operating Procedure

◦ Other

Hot Rod Coyote Engine

Installation Instructions



Parts needed	2
Ford Racing Parts	2
Ford Motor Co. Parts	3
Summit Racing	3
Fuel System	3
Air Intake System	3
Other vendors	3
Autozone	3
Supplies	4
Information	4
Engine Prep	5
Exhaust	5
Oil Pressure sender	5
Water Temp Sender	7
Engine Bolts	11
Alternator Boss	12
Oil Filter nipple (2015 Coyote & Newer only)	13
CMCV (2015 Coyote & Newer only)	13
Transmission Prep	15
Engine/Transmission Installation	16
Fuel System	18
Fuel pressure regulator	19
Fuel lines	20
Fuel pressure regulator vacuum	21

Cooling system.....	23
Vacuum ports and PCV vent.....	31
Tough emissions.....	32
Relaxed Emissions	35
Steering shaft.....	38
Wiring	40
Speed Dial – 2011-2014.....	41
Speed Dial connections.....	44
Harness install	44
Computer mounting.....	44
Black circuit Board box	50
Fuel Pump	55
Neutral Safety switch	57
Clutch position switches.....	58
Radiator Cooling Fan.....	64
Power/start	66
2011-2014	67
2015 & newer.....	68
Starter Solenoid.....	70
2011-2014	71
2015 & Newer	73
O ₂ Harness.....	74
2011-14	74
2015 & Newer	76
Intercooler wire	77
Power Distribution	77
OBD 2 Port	78
Gauges.....	78
Tach	78
Water Temp Sender	80
Oil Temp sender.....	81
Alternator	83
Wiring	90
Air Intake	94
Mass Air Meter	94
Intake tube.....	99
Spectre MAF Sensor	99
Treadstone MAF Sensor	101
Accelerator Pedal	103
Exhaust.....	117
Starting the engine.....	117

Parts needed

Ford Racing Parts

- M-6007-M50A - 5.0L Engine
- M-6017-A504VA – 2011-14 5.0L engine control pack with speed dial
- M-6017-A504V – 2015 & newer 5.0L engine control pack
- M-7003-R58C - TKO transmission
- M-7771-A – Bellhousing bolt kit
- M-9680-M50 – 5.0L engine cover kit
- M-7007-A – Transmission Sandwich plate
- M-6392-M46 - Bellhousing
- M-7560-T46 – Clutch kit
- M-7515-A – Clutch fork



M-6375-G46A – Flywheel (If not already on engine)
M-7548-A – Clutch Release Bearing or Ford motor F7ZZ.7548.AA
M-6397-B46 – Clutch bolt kit
M-7600-B – Pilot bearing (If not already on engine)
M-4209ADPT-AC - Speed Dial (speedo signal changer, 2011-2014 only)

Ford Motor Co. Parts

F3LY-6C070-A – Flywheel access hole plug
BR3Z-8260-BA – Mustang upper radiator hose
W500310.S438- Starter bolts (3 needed)
BR3Z-6379-A – Flywheel bolt (8 needed)
AL3Z-6890-A – 2015 & newer only - Oil filter nipple to eliminate oil cooler spacer plate.

Summit Racing

FUEL SYSTEM

AEI-13129 – 6AN Fuel pressure regulator
SUM-220166B – 6AN O-ring to straight 6AN Adapter (2 needed)
SUM-220701-B – 6AN to -6AN Hose Barb (1 needed)
FRA-495110-BL – 6AN O-ring to straight -4AN Adapter (1 needed)
SUM-220700-B – 4AN Hose Barb (1 needed)
SUM-220711-B – 90° -6AN to -6AN Hose Barb (1 needed)
SUM-800199 – 0-100 EFI fuel pressure gauge
GSL392BX – Fuel Pump or VOR-8F002-265 Fuel pump
VPN-400-939 – Fuel pump mount/barbs for GSL392BX pump

AIR INTAKE SYSTEM

👉 Two possibilities

SPE-9741 – 4” to 3.50” Reducer adapter
SPE-9771 - 4” hose coupling
SPE-9799 - 4” 90 ° intake tube
SPE-9705 - Mass Air Sensor filter adapter
KNN-RU-5149 – 4” ID x 6.50” long Air Filter

Or use

www.treadstoneperformance.com – MAPHL35
90° 3.50” Silicone hose
FFR air filter

Other vendors

AUTOZONE

2005 Ford Mustang GT Starter – DL3299S or similar*
Short oil filter - Fram PH10060 or Mobil M1-113 or STP S10060



☞ If not running A/C, a small 1-wire alternator can be used in the stock compressor location. If A/C is being used, the following alternator can be used with the brackets described.

2001-03 Honda Civic DX 1.7L MFI SOHC Alternator – 12308



Supplies

Oil – See instructions with engine - 8 quart
Coolant –2-3 gallons of **Dex-Cool concentrate**
Transmission fluid
Teflon tape

Information

These instructions assume that the customer has the Coyote Installation kit from Factory Five Racing. Make sure to download the latest version of the engine controls instructions from the Ford Performance parts website: www.performanceparts.ford.com . Do a parts search for: M-6017-A504V and click on the instructions pdf.

Use the following diagram as a guide for harness locations.

1	Engine starter
2	Engine computer
3	Power distribution
4	Black circuit board box
5	OBD 2 port
6	Accelerator pedal

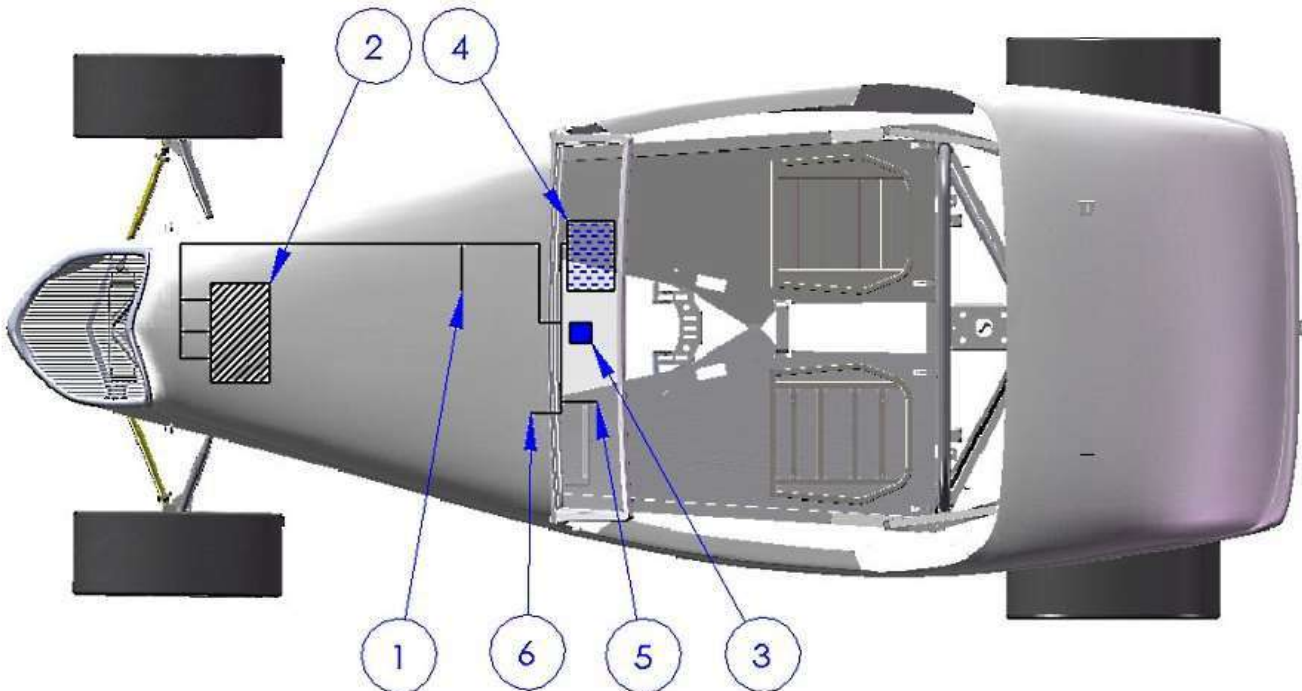

Engine Prep

Exhaust

Remove the Stock Mustang headers.

Remove all of the header studs using a 6mm 6 point socket.

Oil Pressure sender

- 🛠 Pipe fittings, Gauge assembly
- ✂ H14 Hex key, 12mm deep, $\frac{13}{16}$ " , $1\frac{1}{16}$ " sockets, ratchet, Teflon tape, ratchet extensions, $\frac{3}{8}$ " , (2) $\frac{9}{16}$ " , $\frac{11}{16}$ " , $\frac{7}{8}$ " wrenches, vise grips

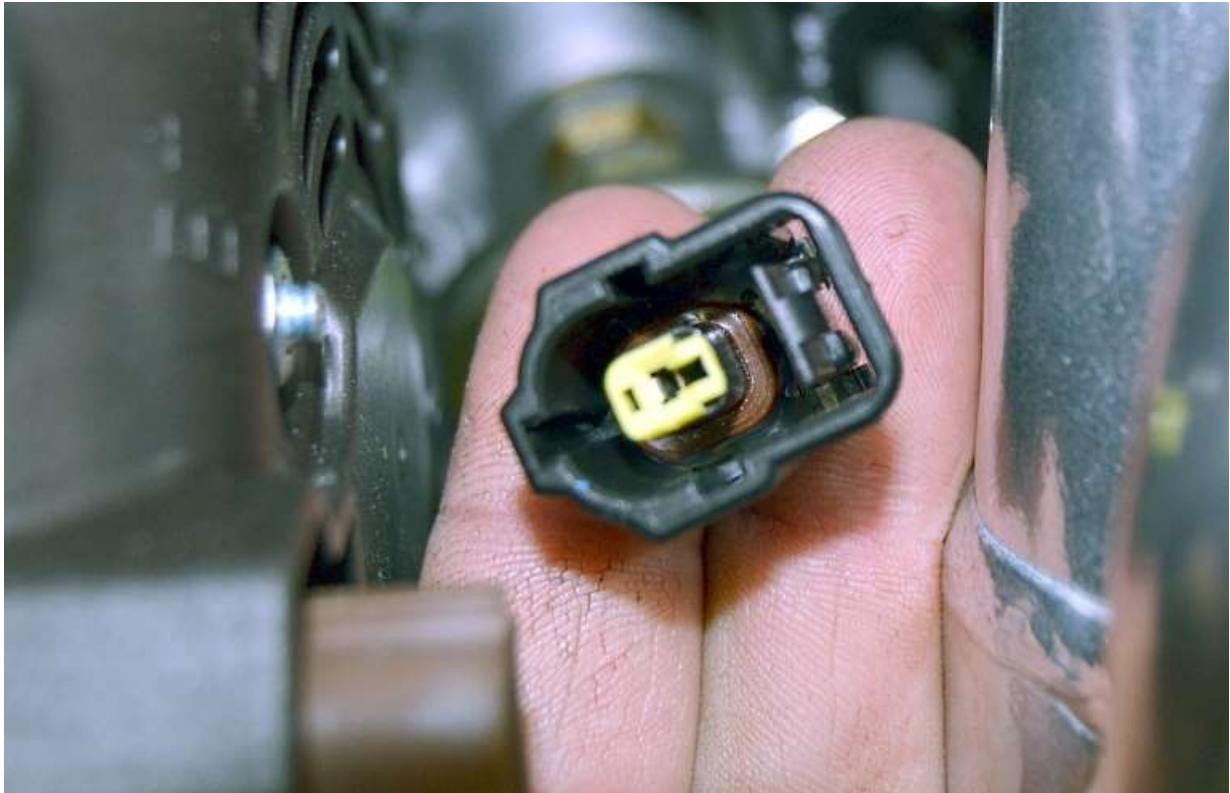

Remove the stock oil pressure gauge sender plug from the block located on the left front side of the engine. This plug will not be used again.



Remove the stock oil pressure gauge sender from the block located behind the alternator. This Sending unit will not be used again.

☞ Actual sending unit used depends on the gauges, shown are the Autometer senders.



Use Teflon tape and install the oil pressure gauge sender.



From the gauge box, screw on the 1/4" NPT adapter then screw the Sending unit into the block.

Water Temp Sender

- ✂ H14 Hex key or socket, 1 1/16" socket, 12mm deep socket, extension, ratchet, Teflon tape
- 🔩 Water temp gauge sending unit

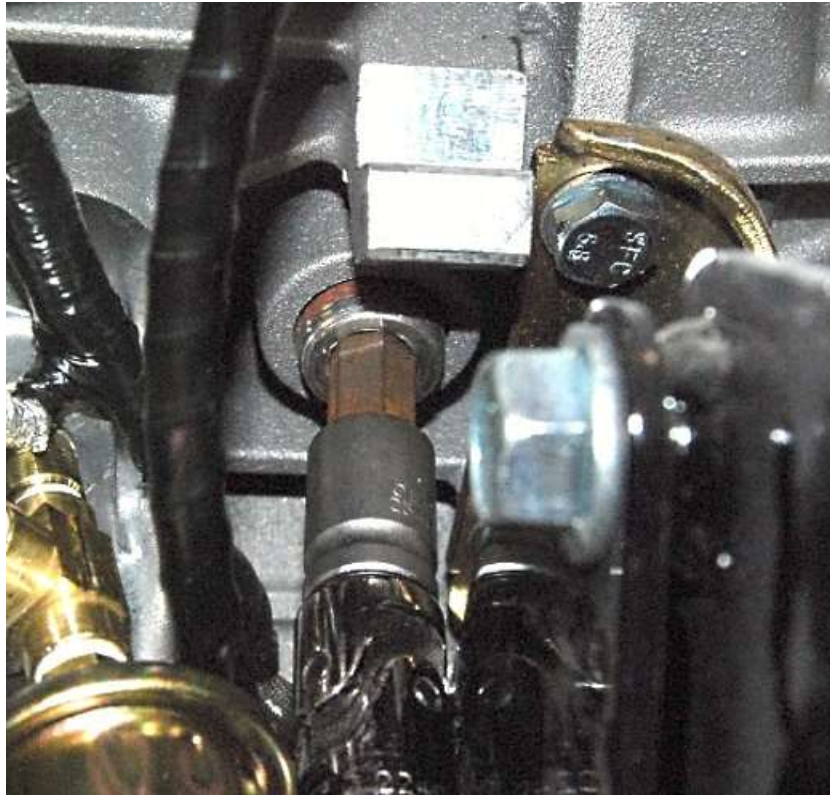

Remove the $\frac{3}{4}$ " NPT plug from the side of the block using a H14 Hex key or socket.



Put Teflon tape on the $\frac{3}{4}$ " NPT to $\frac{1}{2}$ " NPT adapter.

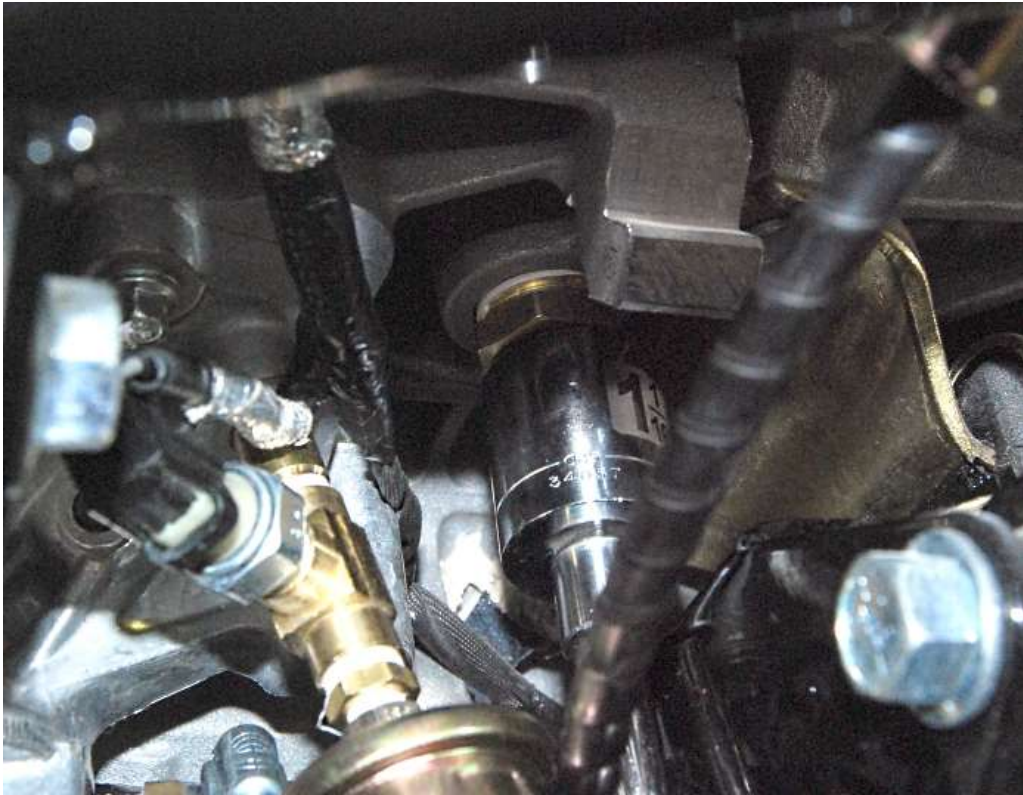

Screw the adapter into the block using a 1 1/16" socket.



Use Teflon tape on the 1/8" NPT to 1/2" NPT adapter included with the gauge.



Screw the adapter into the larger adapter on the block.



Put Teflon tape on the sending unit.



Use a 12mm deep socket to screw the sender into the adapters.

Engine Bolts

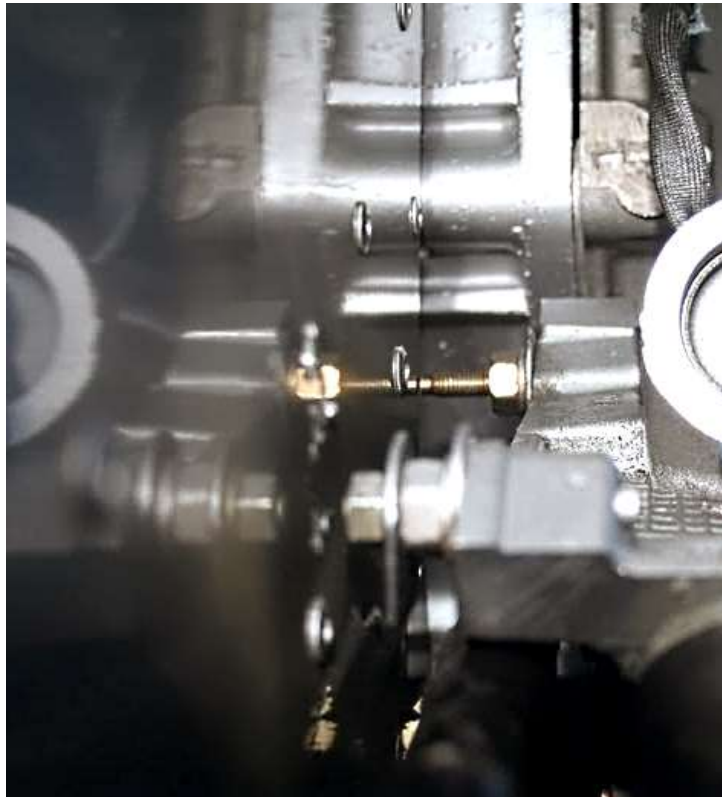

The engine ends up extremely close to the firewall. Cut any extra length off the bolts sticking out the back of the engine to prevent damaging the firewall.

Alternator Boss

- ✂ Hack saw or jig saw
- ✎ Use a hack saw or sawzall with a course wood blade, a fine metal blade will get gummed up with the aluminum.



Use a Marker to mark the top stock alternator boss on the driver side as shown. It will hit the frame otherwise.

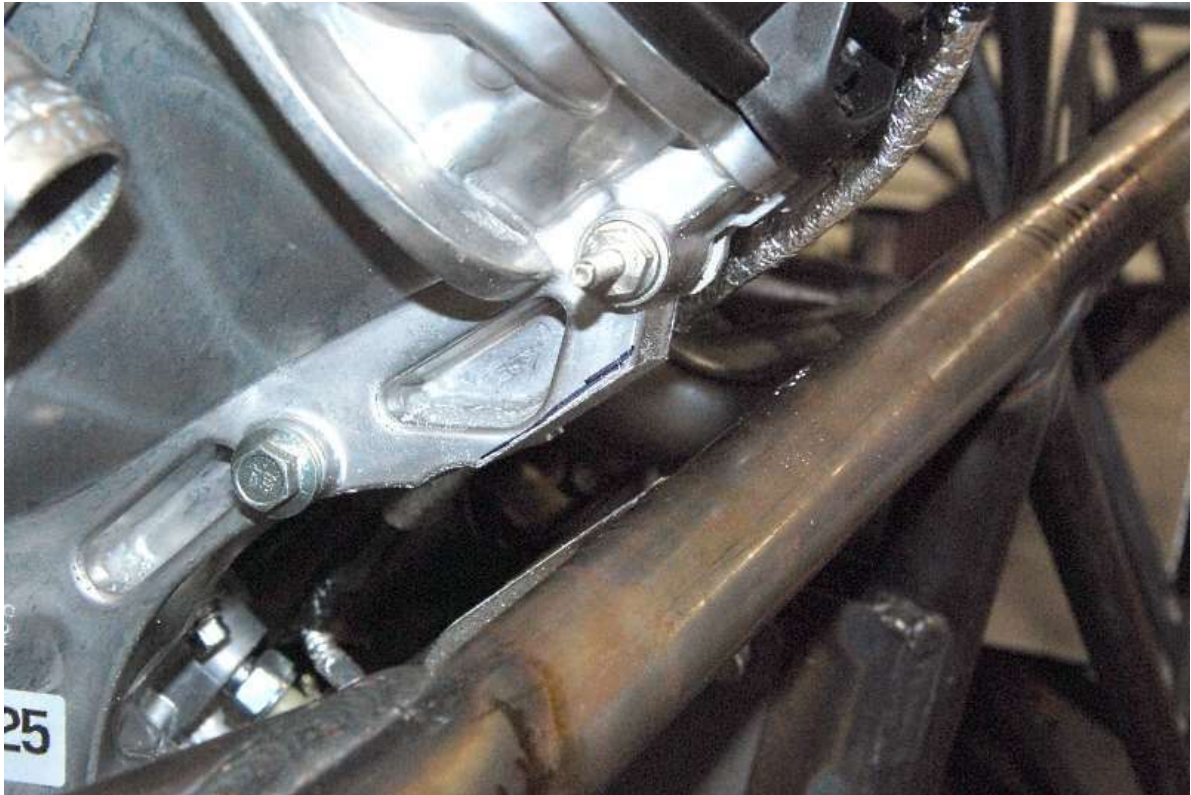

Cut the boss on the line marked with a jig saw.

Oil Filter nipple (2015 Coyote & Newer only)

The 2015 Coyote comes with an oil cooler spacer plate under the filter. Remove this from the engine. A nipple is needed to eliminate the cooler plate and allow the filter to attach directly to the block to fit in the chassis. Use the following Ford part to attach the filter: AL3Z-6890-A.

CMCV (2015 Coyote & Newer only)

- ✎ Charge Motion Control Valve - These valves introduce tumble and swirl into the airflow at part throttle, maximizing combustion efficiency.
- ✎ The coyote install in the Hot rod is very tight against the firewall, the new CMCV's stick out past the back of the block and therefor need to be disabled.

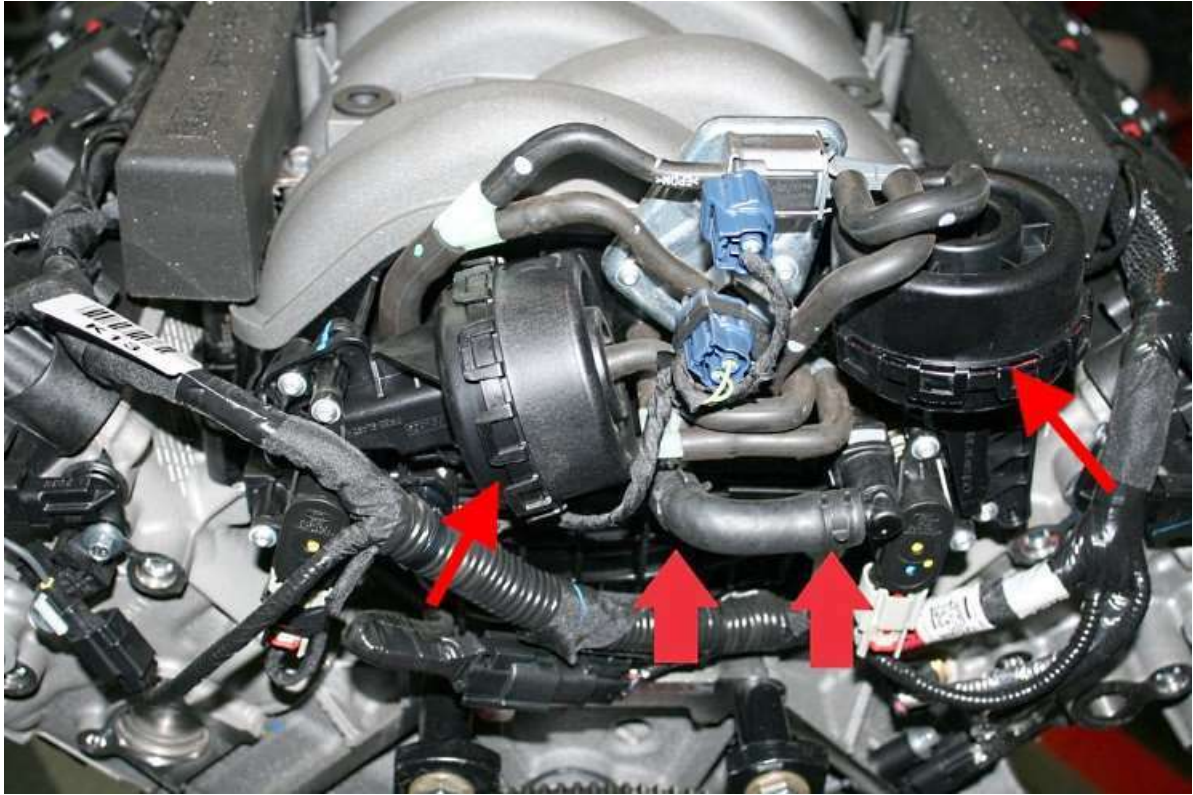

The CMCV actuators and PCV tube.



Shorten the end of the vacuum nipple as much as possible to prevent the tube from hitting the firewall as shown.

Remove the CMCV actuators and block off the vacuum feeds.

When standing in front of the engine, the left side CMCV shaft needs to be rotated clockwise and locked in place.

When standing in front of the engine, the right side CMCV shaft needs to be rotated counterclockwise and locked in position.

Transmission Prep

- ✂ Hack saw or Reciprocating saw, $\frac{3}{4}$ " socket, ratchet
- 🚗 Transmission, Polyurethane engine/transmission mount kit
- 👤 The two aluminum spacers provides are not used.



If you are using a Tremec 3550, TKO 500 or, a TKO 600 you will need to trim off the unused mounting boss on the bottom of the case.

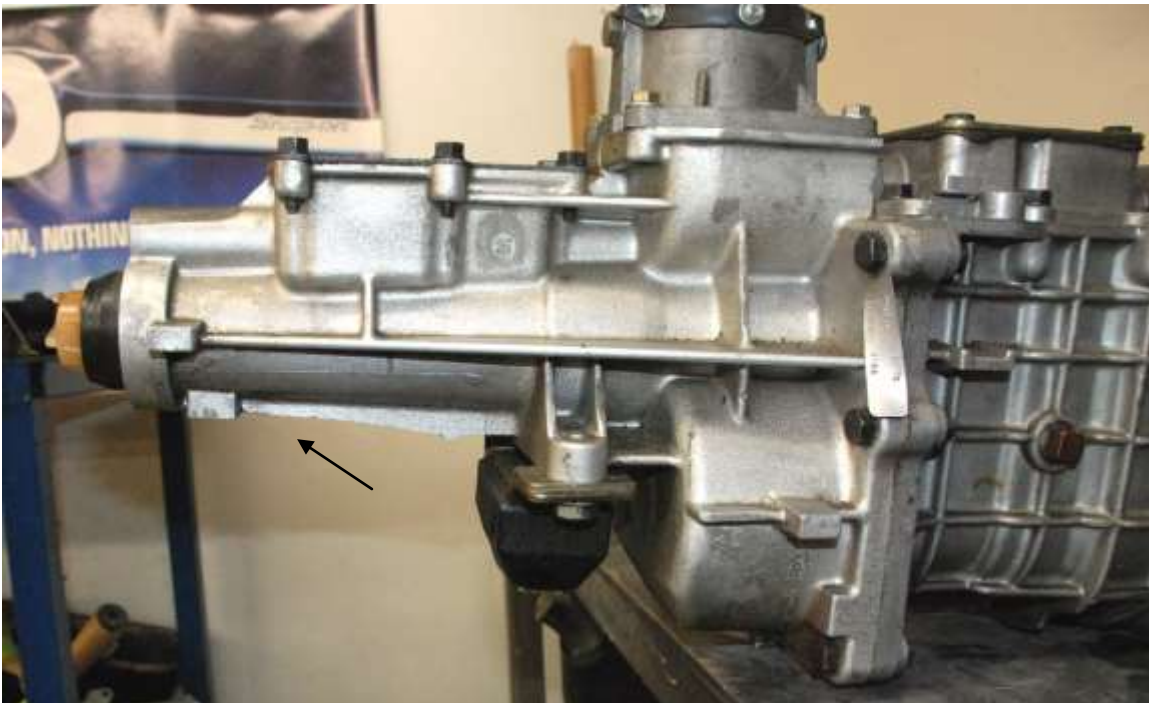

Trim it flush or just below the pad for the transmission mount.

If not already done, install the flywheel and clutch on the engine.



Remove the vibration damping weight from the clutch fork, it is not needed.

Attach the bellhousing and clutch fork to the engine.

Attach the transmission to the engine.

Engine/Transmission Installation

If electric steering is installed, undo the mounting bolts and rotate the motor down out of the way.



Install the engine and transmission per the assembly manual.





Attach the polyurethane transmission mount to the frame mount and transmission using the 1.09" and 0.32" spacers provided.



If using electric steering, reattach the motor mounting bolts. Make sure there is some clearance between the oil pan and motor. Redrill/slot one or two of the mounting holes if necessary.

Fuel System

-  Fuel pressure regulator, fittings, fuel hose, hose clamps, high pressure fuel pump
-  The Coyote engine requires a 255 lph high pressure fuel pump such as the Summit Racing SUM-G3138 Fuel Pump. Either an inline pump or in-tank pump can be used depending on preference.

Fuel pressure regulator



Mount a fuel pressure regulator to the firewall and connect the appropriate fittings, the return is on the bottom.

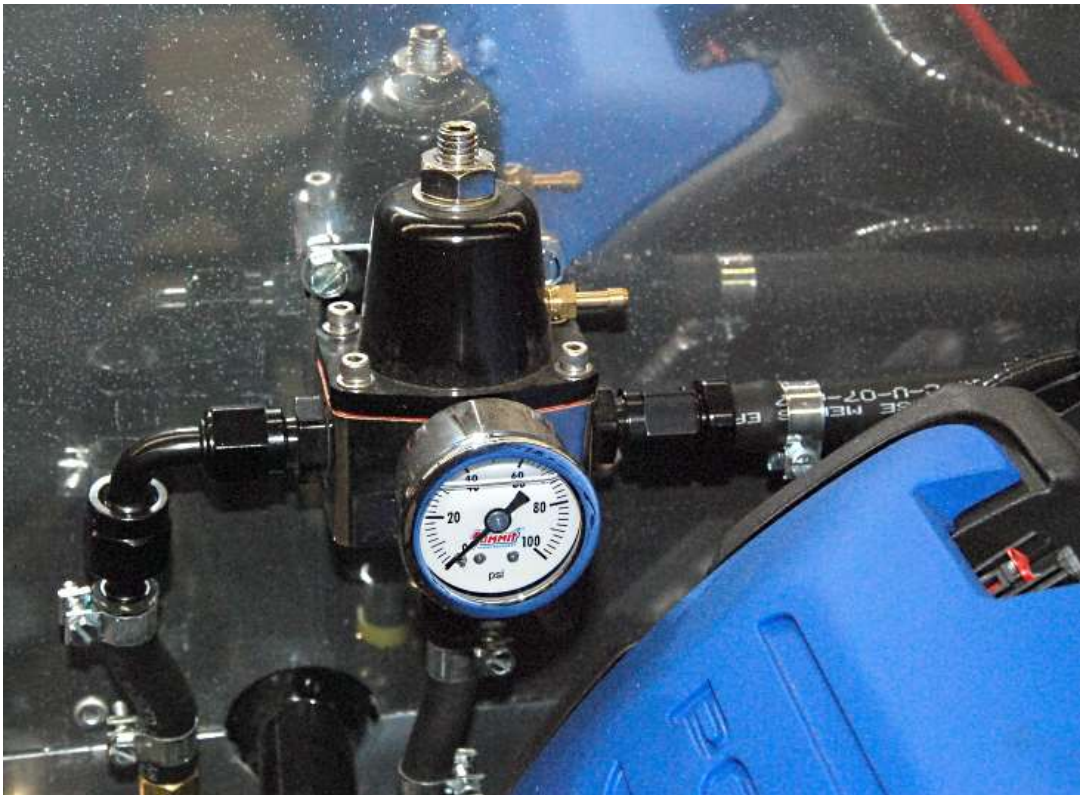

Push the $\frac{3}{8}$ " fuel line onto the right side of the regulator then attach a hose clamp and run it over to the engine fuel rail.

Fuel lines

Push the white fuel line connector onto the fuel rail.

Hold the fuel line up to the connector and cut it to length with a razor knife.

Remove the fuel line connector.

Slide a hose clamp onto the hose then push the fuel line connector into the hose and tighten the clamp.



Push the white connector onto the fuel rail.

Fuel pressure regulator vacuum

Cut a 2.50" section from the length of 1/2" hose provided.

Assemble the 1/2" to 5/32" 90 degree adapter.

Push the 1/2" side into the short section of 1/2" hose and fasten with a hose clamp.

Slide a second hose clamp onto the hose.

Push the vacuum line onto the hose adapter.



Push the ½" hose onto the vacuum port on the right side of the throttle body so the small end points towards the firewall and tighten the hose clamp.



Run the vacuum line to the fuel pressure regulator and push it onto vacuum barb.

Cooling system

- ✂ Razor knife, flat head screwdriver, wire cutters, hack saw, marker, $\frac{5}{16}$ " socket, ratchet.
- 🔧 Stainless radiator hose kit

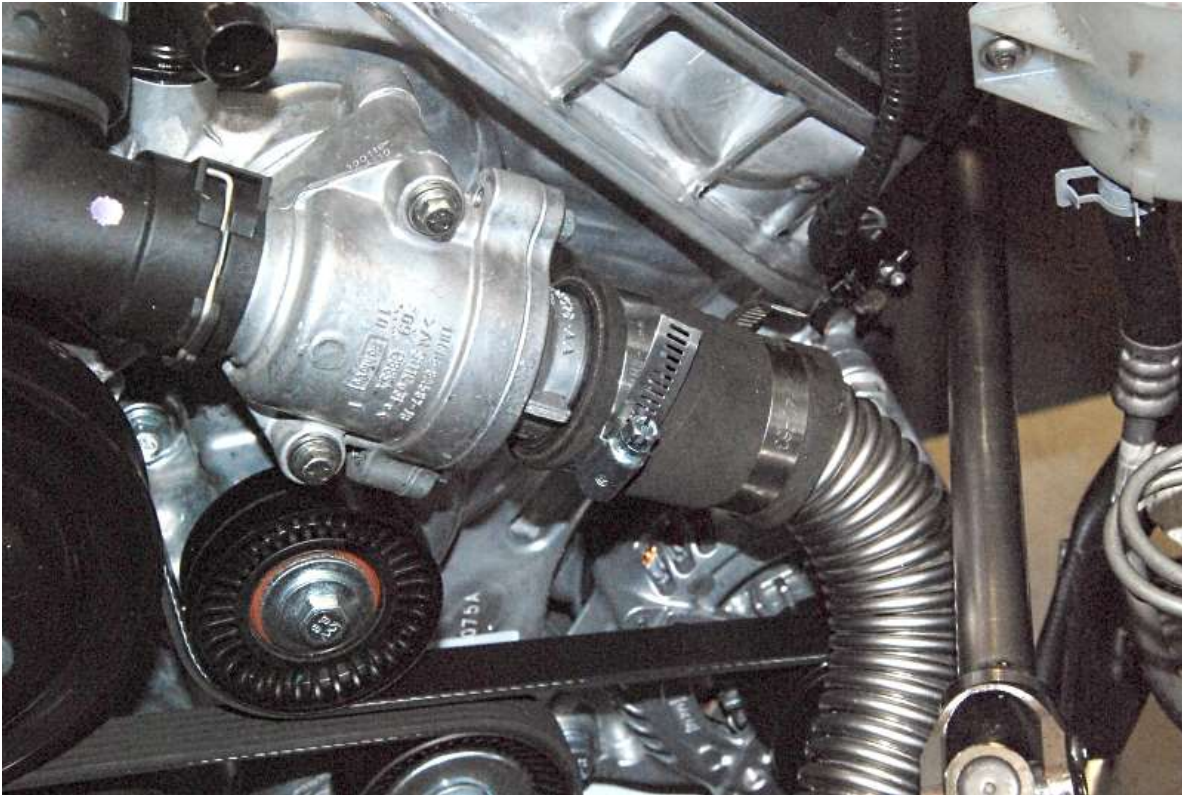

Push the correct size adapters onto to the thermostat housing with a length of the stainless hose.



Route the stainless hose to the left side lower radiator outlet and mark the hose for cutting.

Remove the stainless hose and cut it where marked with a hack saw.
Reinstall the hose.



Cut the plastic clamp off the stock upper hose.



Cut and remove the rubber hose from the plastic adapter.



Attach one of the kit hose adapters to the plastic adapter



Push the adapter onto the engine.



Attach another hose adapter to the radiator.



Route and cut the radiator hose so that the hose curls towards the right side of the car not the left (the air filter goes there). Push the bypass caps onto the tubes to the left of the throttle body and hose clamp the lower one.

- ✎ For air bleeding later, remove the top cap until coolant starts going up the tube then recap and hose clamp.
- ✎ This top one is one of the heater core hose locations if running a heater and A/C.

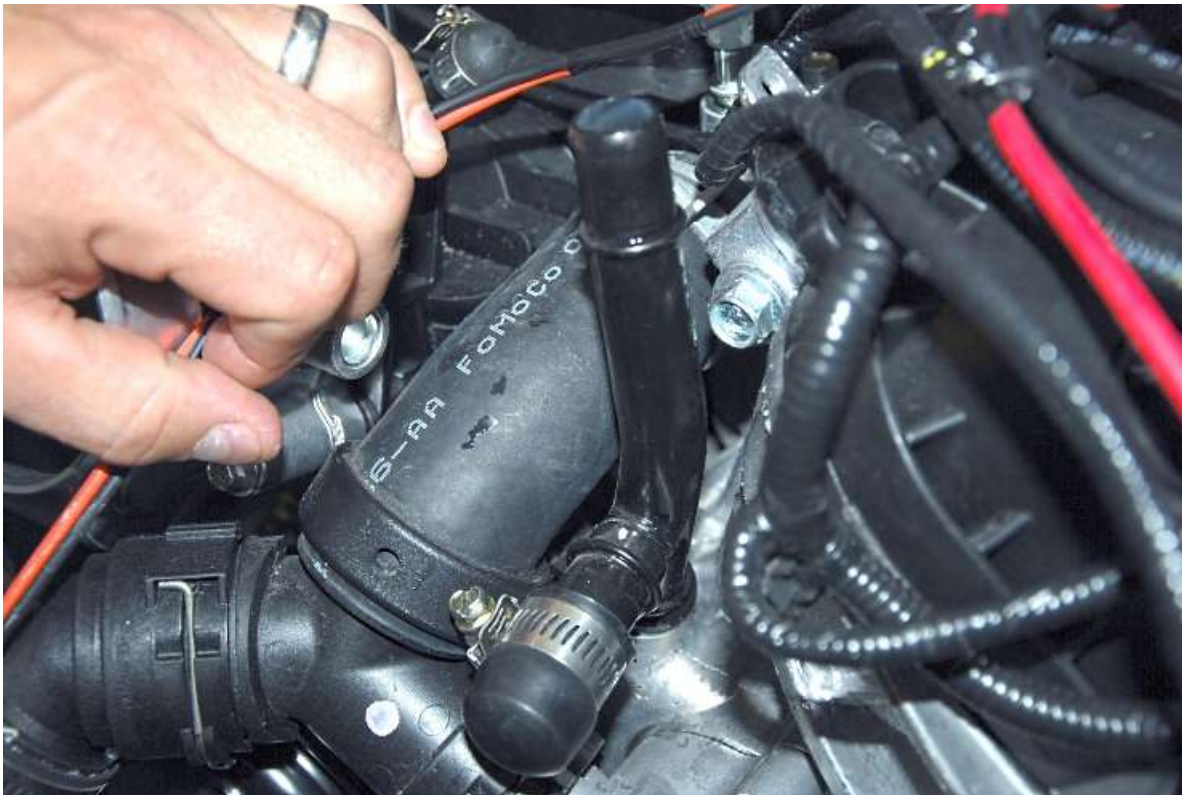

Push the bypass caps onto the lower tube to the left of the throttle body and hose clamp it.

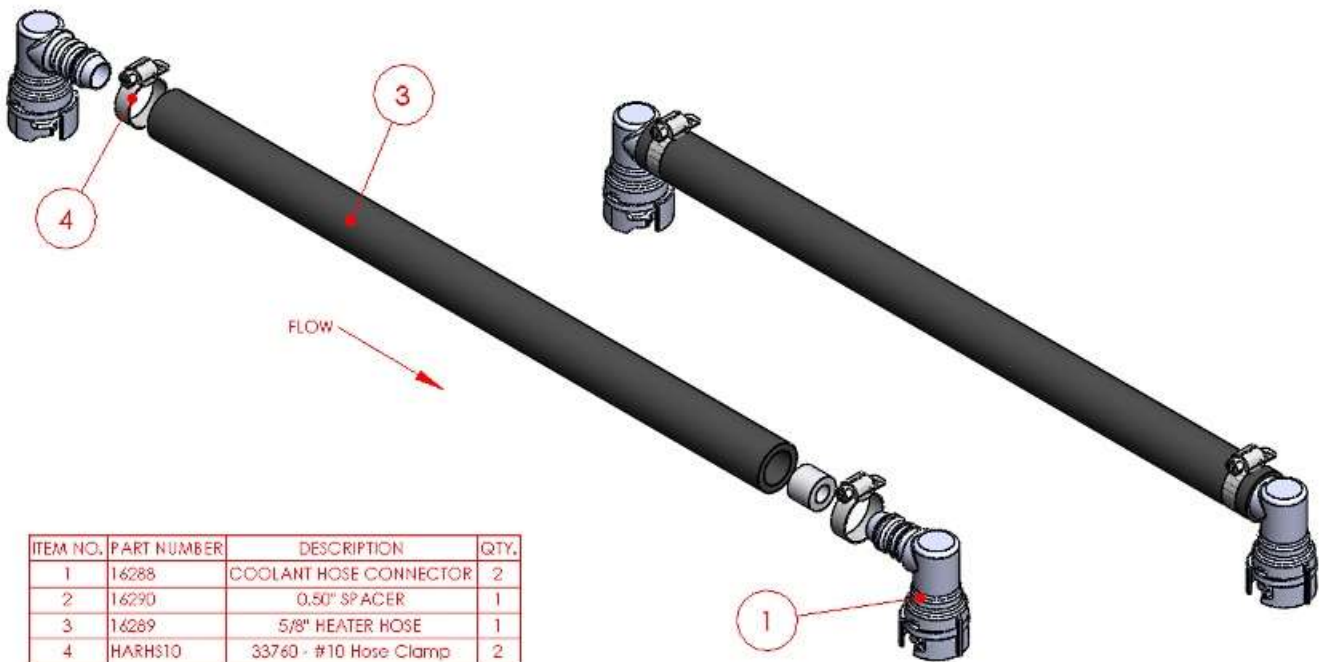

Assemble the right side of the heater bypass hose, insert the 0.50" aluminum spacer into the $\frac{5}{8}$ " heater hose followed by a hose clamp then push one of the 90° plastic coolant hose adapters.

Tighten the hose clamp using a $\frac{5}{16}$ " socket and ratchet.



Push the hose onto the top of the tube to the left of the throttle body.

Push the other adapter onto the tube on the right side of the intake then measure and cut the $\frac{5}{8}$ " heater hose so that it will connect to the adapter and route where desired.



Put a hose clamp on the hose, push it onto the coolant adapter and tighten the hose clamp.

- ✎ For air bleeding later, remove the 90° plastic coolant hose adapter until coolant starts going up the tube then recap and hose clamp.
- ✎ This top one is one of the heater core hose locations if running a heater.



Push and hose clamp the small coolant barb behind the 3/4" coolant tubes.



Cap and hose clamp the 3/4" coolant.



This is the other heater core location if running a heater.

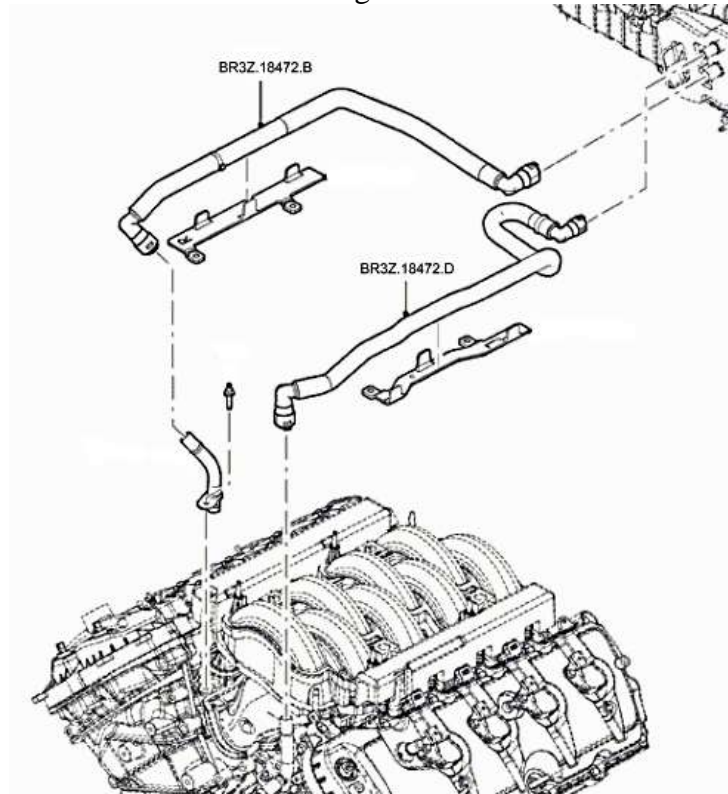

If running a heater or A/C, use the bypass hose connectors and some heater hose to connect to the heater.

Vacuum ports and PCV vent



Flat head screwdriver, razor knife, WD40



Vacuum plugs, PCV lines, 1/2" rubber hose, T connector



There are a couple ways to route the PCV hose depending on your emission requirements (tough or relaxed)



Block off the vacuum ports and fuel evaporator intake tube just behind the throttle body.

Tough emissions



If not already done, connect the right side stock PCV hose from the valve cover to behind the throttle body.

Install a 1/2" barb fitting in the intake tube after the mass air meter but before the throttle body.



Carefully cut the 90° PCV fittings out of one of the pcv lines without damaging the barbs.



Push the 1/2" heater hose onto the PCV fitting.



Attach the fitting to the left side valve cover.

Run the hose over to the intake barb and cut the hose to length.
Use a hose clamp to attach the hose to the intake tube.

Relaxed Emissions



Carefully cut the 90° PCV fittings off the pcv lines without damaging the barbs.

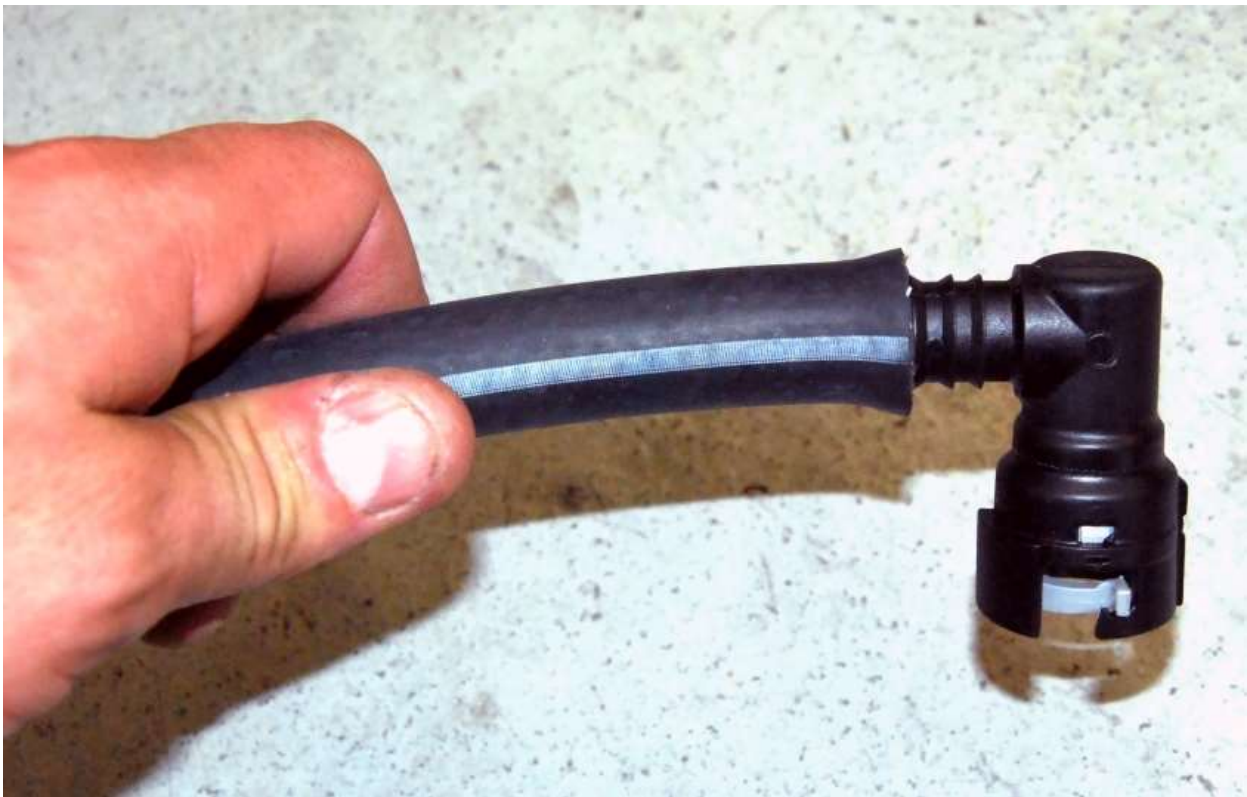

Spray some WD40 into the end of the hose and push the ½" heater hose onto one of the PCV fittings.



Push the fitting onto the left valve cover and run the hose forward just left of the throttle body.



Push the fitting onto the right valve cover and run the hose around the front of the engine to the left side.

Insert the “T” fitting into left side hose.

Cut the Right side hose so that it will go onto the “T”.



Push the right side hose onto the “T”.



Push the remainder of the hose onto the third leg of the “T” and run it down behind the coolant inlet.



Run the hose under the oil pressure sender then over the electric steering (if used) and cut the hose.

Steering shaft

- ✂ Hack saw, $\frac{7}{16}$ " socket, ratchet, $\frac{3}{16}$ " drill bit, drill, $\frac{3}{16}$ " hex key
- 🛠 Hot Rod steering parts

Remove the middle steering shaft that goes from the firewall to the lower steering bearing in the engine bay. Cut the shaft into two sections, $8\frac{7}{8}$ " for the lower shaft and 4.25" for the upper shaft.

Assemble the two shaft pieces with the included steering joint with the short half of joint on the long shaft. Slide the $\frac{3}{4}$ " pillow block onto the long shaft with the bearing lock pointed away from the steering joint. Assemble the shaft on the frame so that the ends of the shafts are flush with the inside of the joint. Loosely attach the tube clamps to the 1" round tube near the steering shaft.

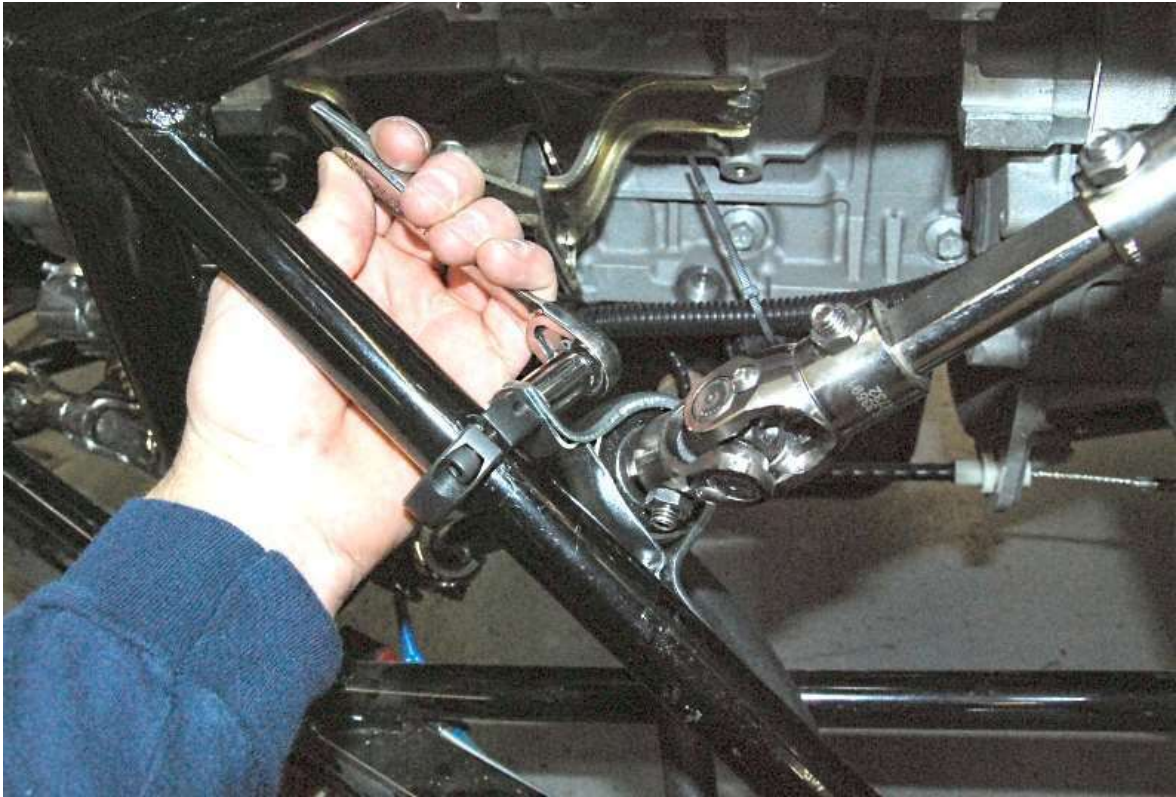

Loosely attach the pillow block to the tube clamps, the screws will not tighten because of the tube.

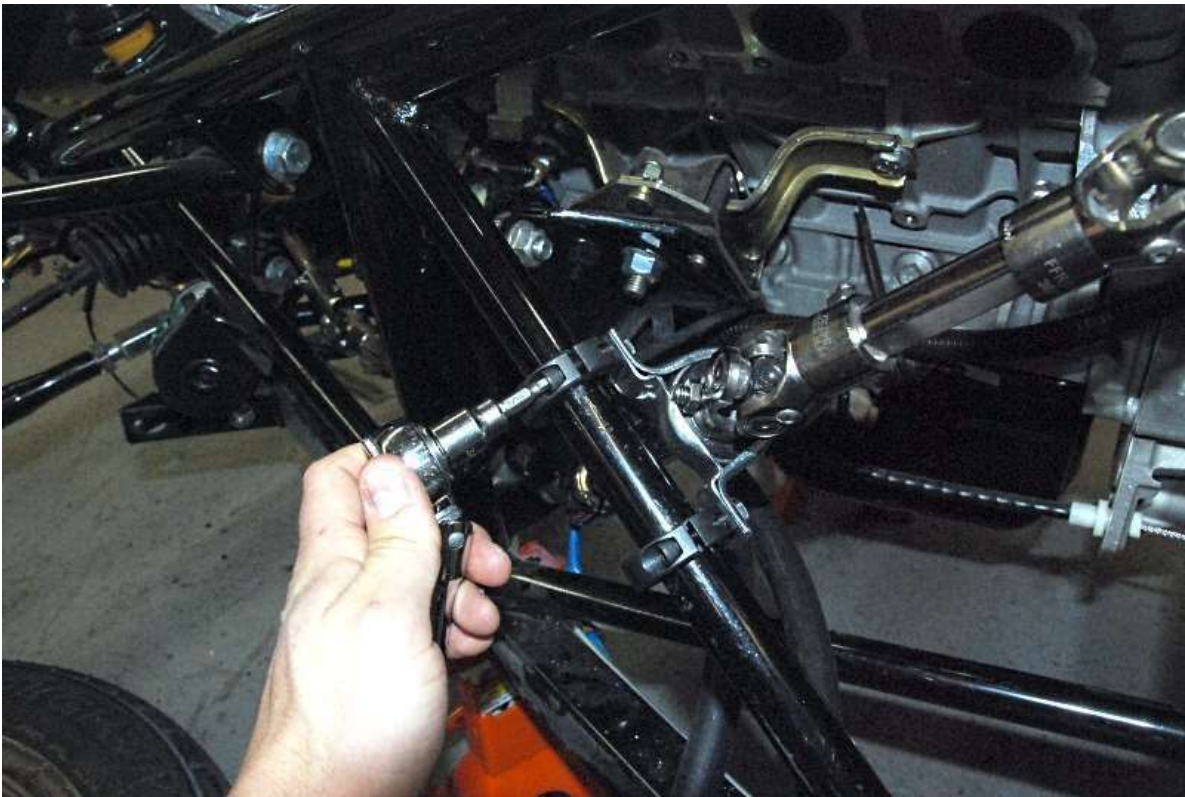

Locate the tube clamps on the tube so that the shaft is as straight as possible and then tighten the clamps.

Remove the pillow block screws and use a marker or small drill bit through the screw hole to mark the location on the 1" tube.

Remove the tube clamps.

Drill the marked locations using a 1/4" drill bit. This will allow the pillow block mounting screw to go into the tube and also prevent the tube clamps from turning or moving if they loosen for some reason. Reassemble the tube clamps and pillow block on the tubes using the pillow block mounting screws in the drilled holes to locate them.



Tighten the set screws on the steering joint and pillow block.

Wiring

- ✂ Soldering iron, solder, electrical tape, wire cutters, wire strippers
- 👉 Use the diagram at the beginning of these instructions for general routing and component location.

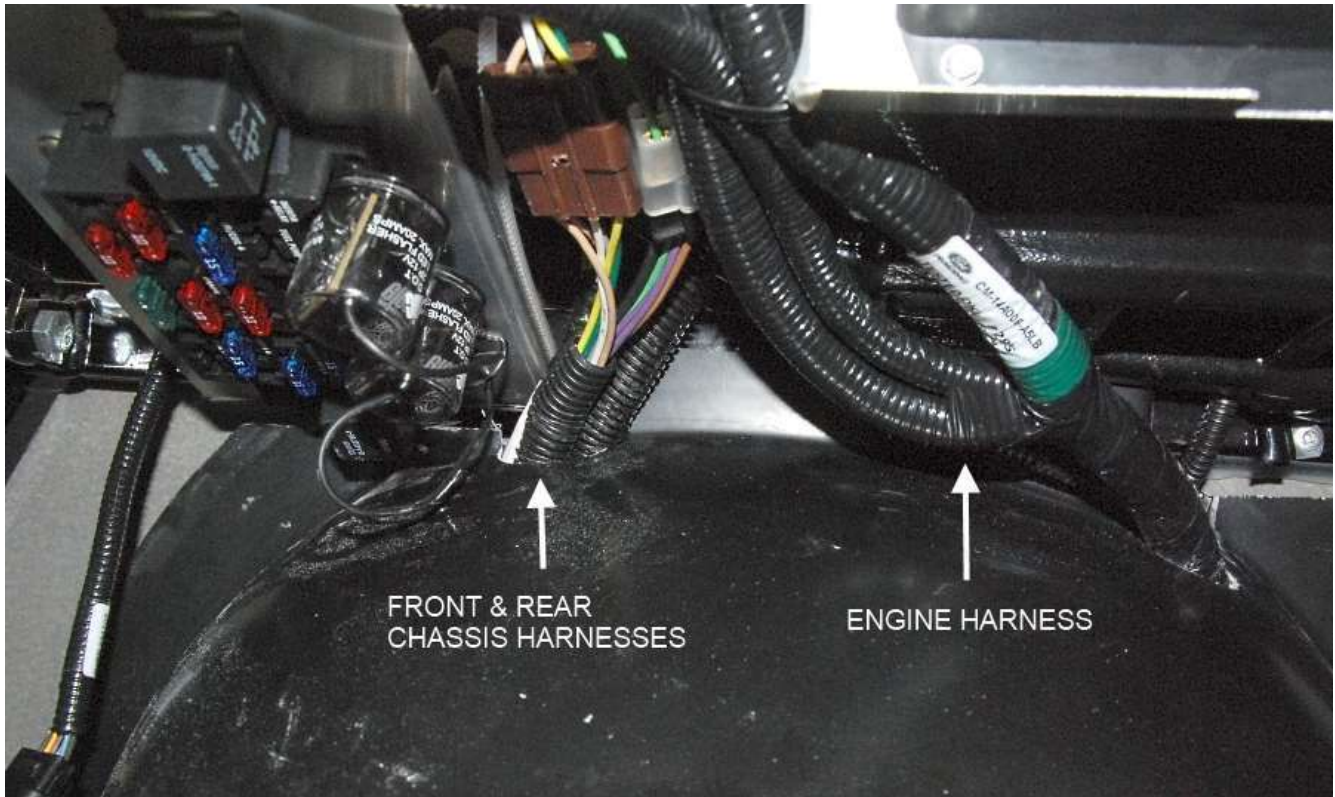

The main wiring harness will exit the cockpit towards the right side of the transmission tunnel.

Speed Dial – 2011-2014



☞ The Speed Dial is only necessary on the 2010-2014 Coyote engine controls. If running a 2015 or newer, skip this section.

- ✎ By adding the Speed Dial, the ECM uses this signal to determine if the vehicle is in motion and uses that data to determine the correct idle characteristics during extended coasting to a stop.
- ✎ If M-6017-A504VA control pack was ordered, the pins are already in this harness.
- 🔧 M-4209ADPT-A Speed Dial, Shrink wrap, Screws or double stick tape (for mounting)
- ✂ Wire cutter, Wire stripper, Soldering iron, Electrical tape, Philips head screwdriver, Small Flathead screwdriver, Razor knife



Remove the cover to the speed dial.

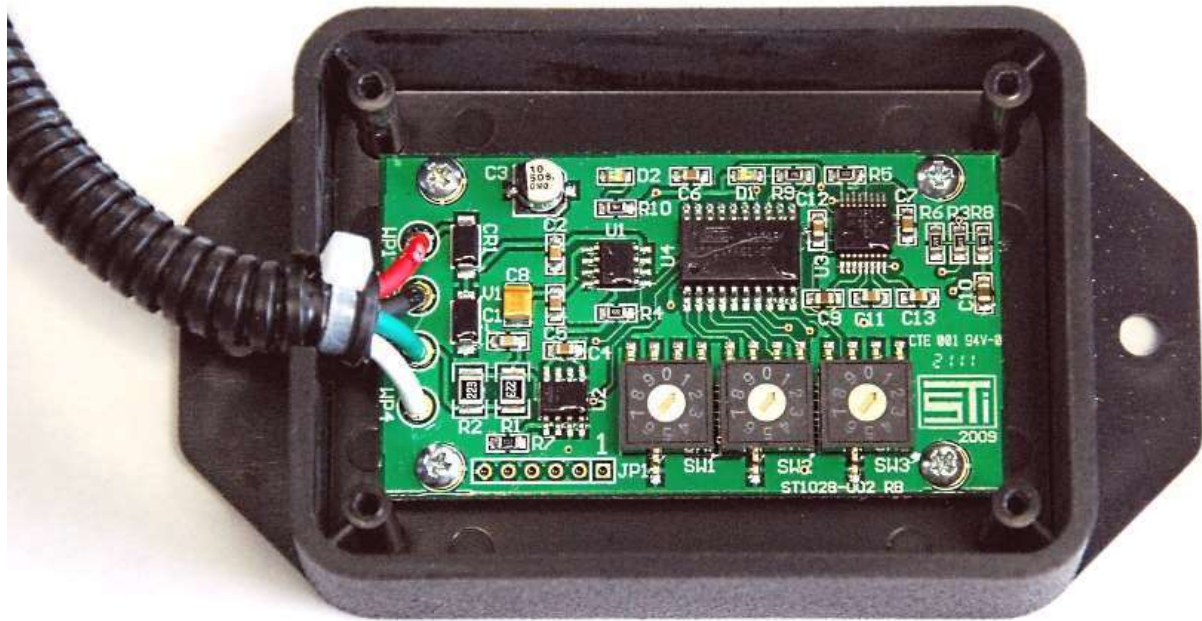

Set the dip switches to 111

Locate a place to mount the Speed



Dial.

If using double stick tape, attach it now.



Attach the Speed dial to the desired mount area.

SPEED DIAL CONNECTIONS

Slide shrink wrap onto the Speed Dial wires then solder the same color wires from the control pack together and shrink the shrink wrap onto the connection.

Harness install

 Use the diagram at the beginning of these instructions for general routing and component location.

COMPUTER MOUNTING

2011-14

 Ratchet, 10mm deep socket, $\frac{5}{32}$ " Hex key, pliers

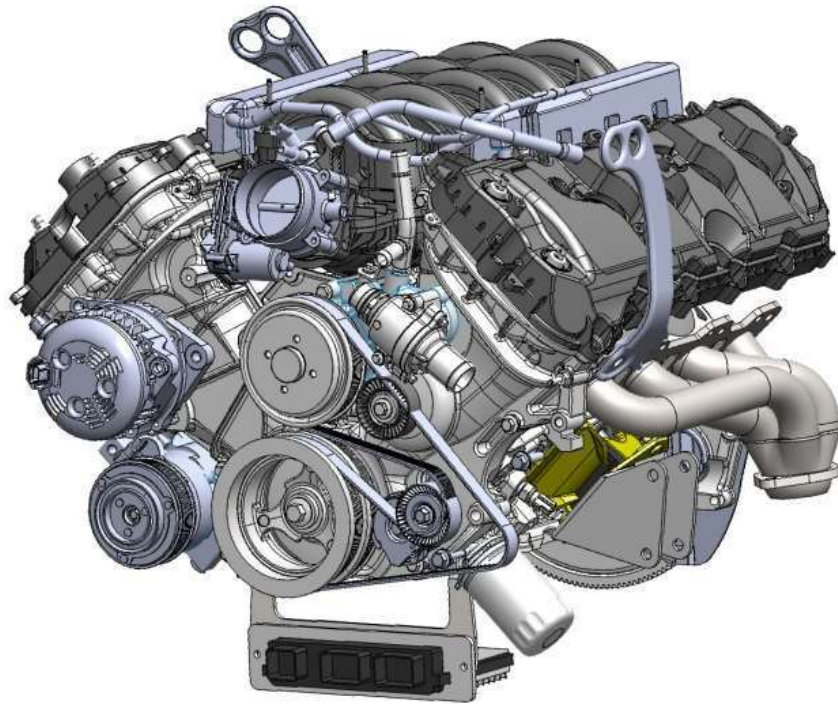

Place the computer mounting bracket onto the front oil pan stud on the right side of the engine as shown and the side mount stud on the left side of the engine.



Use a 10mm deep socket and 6mm locknuts to mount the bracket.



If using electric steering, hold the computer up to the front side of the bracket with the plastic side of the computer on top and check for clearance with the electric steering motor.



If necessary, use a pair of channel lock pliers to bend the computer bracket up slightly so there will be clearance for the computer.

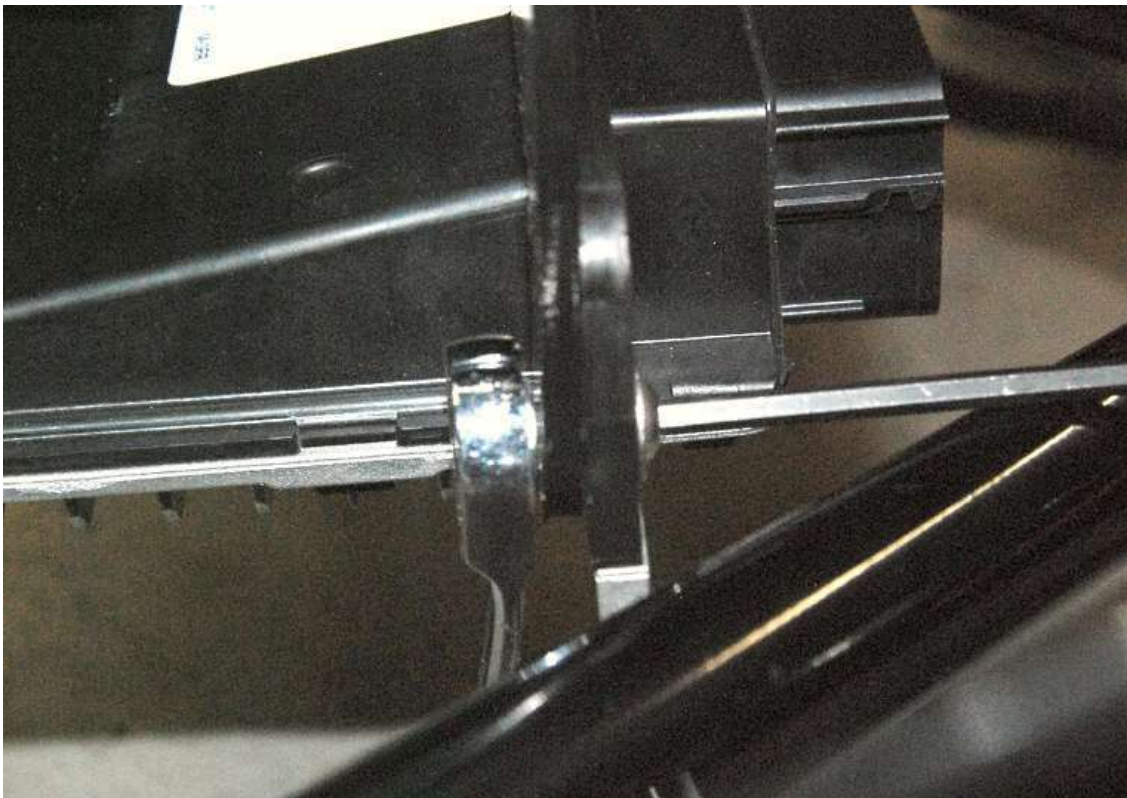

Test fit the computer again then attach the computer to the bracket.



Run the computer plugs on the right side of the oil pan.

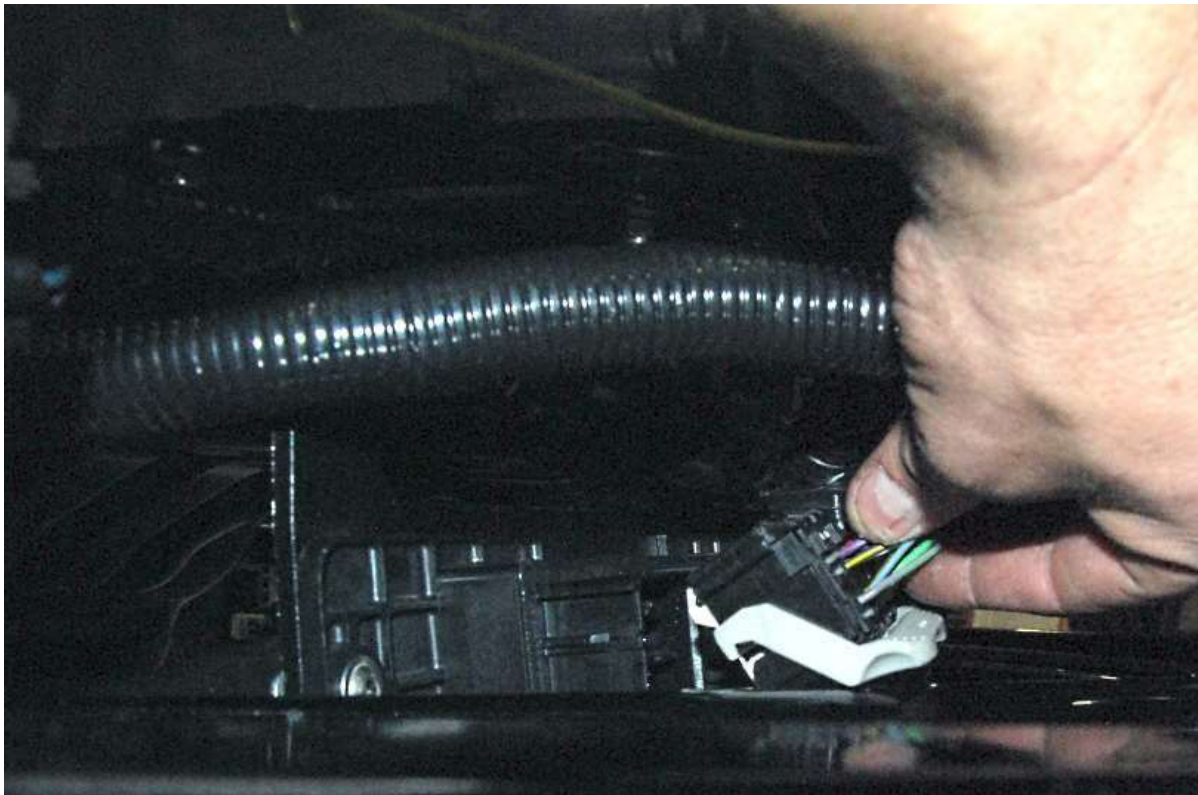

Plug the two engine harness plugs into the computer.



Pull the harness tight along the oil pan and zip tie the harness to the mounting eyes on the oil pan.

2015 & newer

??

Black circuit Board box

✂ Small and Large Philips head screwdriver

Inside the car, find a location that you can mount the black box from the coyote harness. We mounted it to the left of the center support.

👉 Do not mount the box yet.

Open the black box and remove the nut on the post marked “fan”.

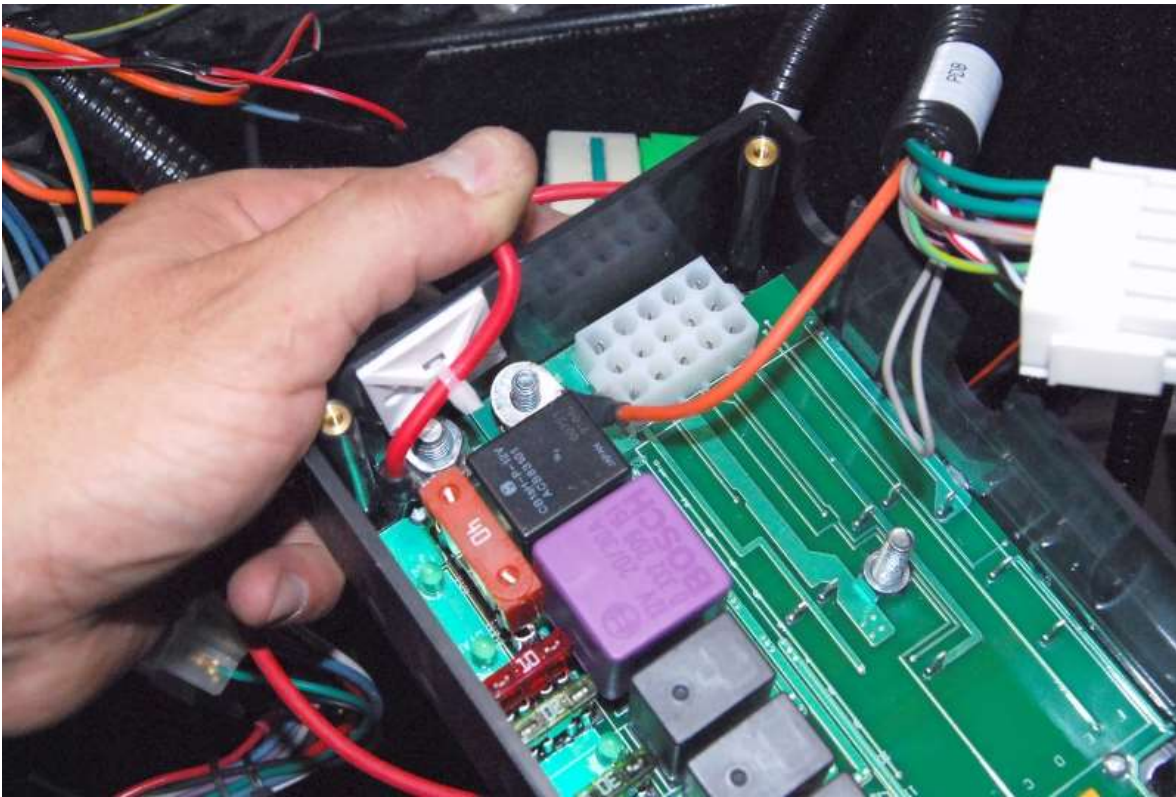

Put the orange wire ring connector onto the post.

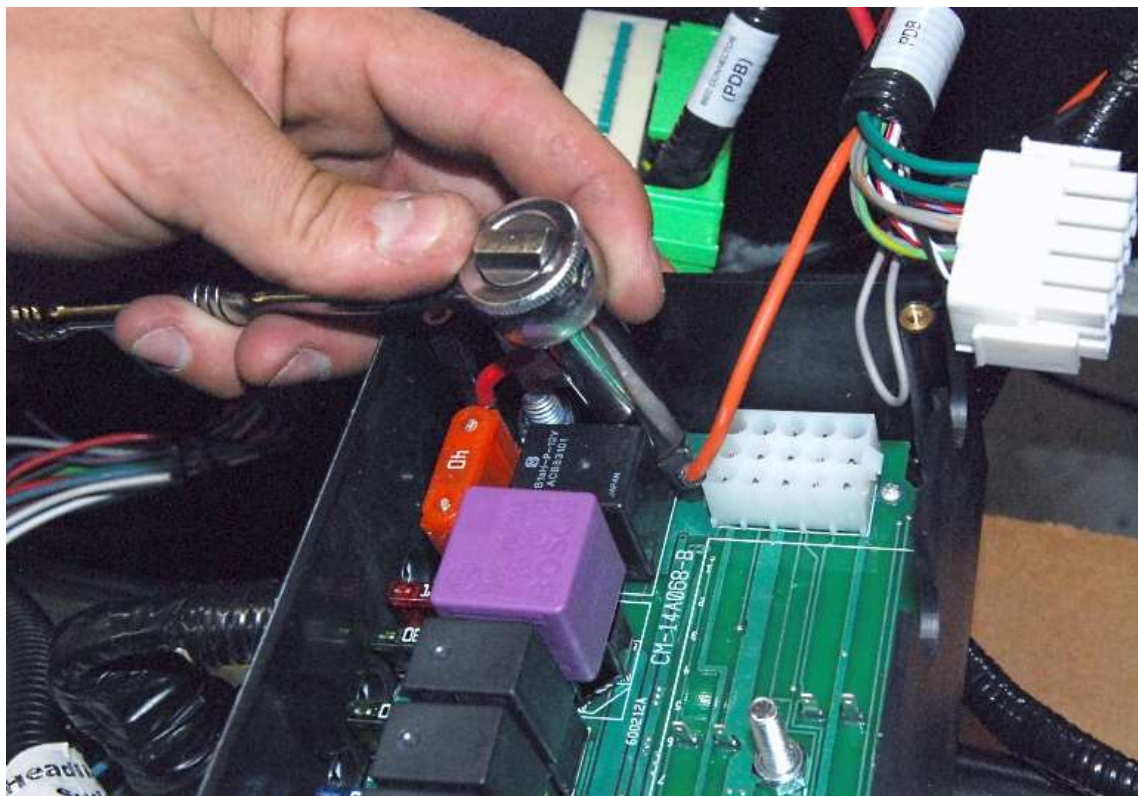

Tighten the nut on the fan post then bend the ring connector up so the wire clears the white connector.

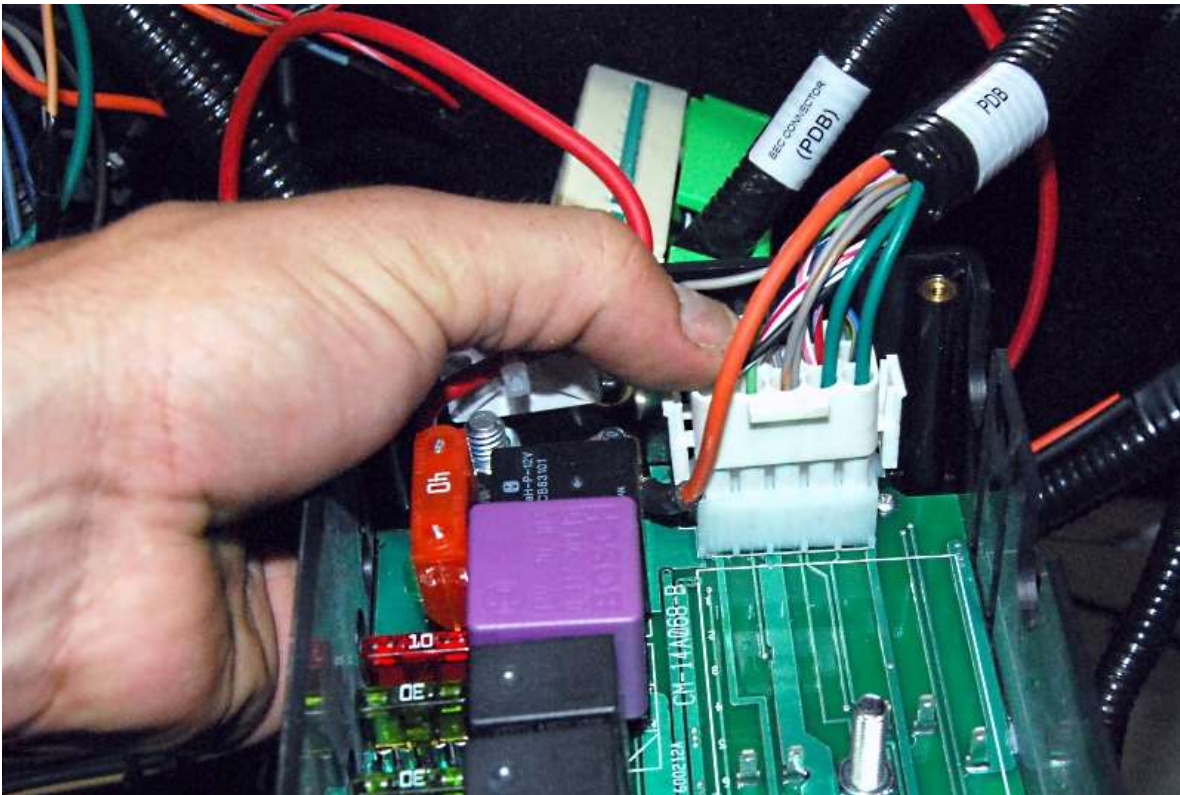

Push the white multipin connector onto the matching connector on the circuit board.

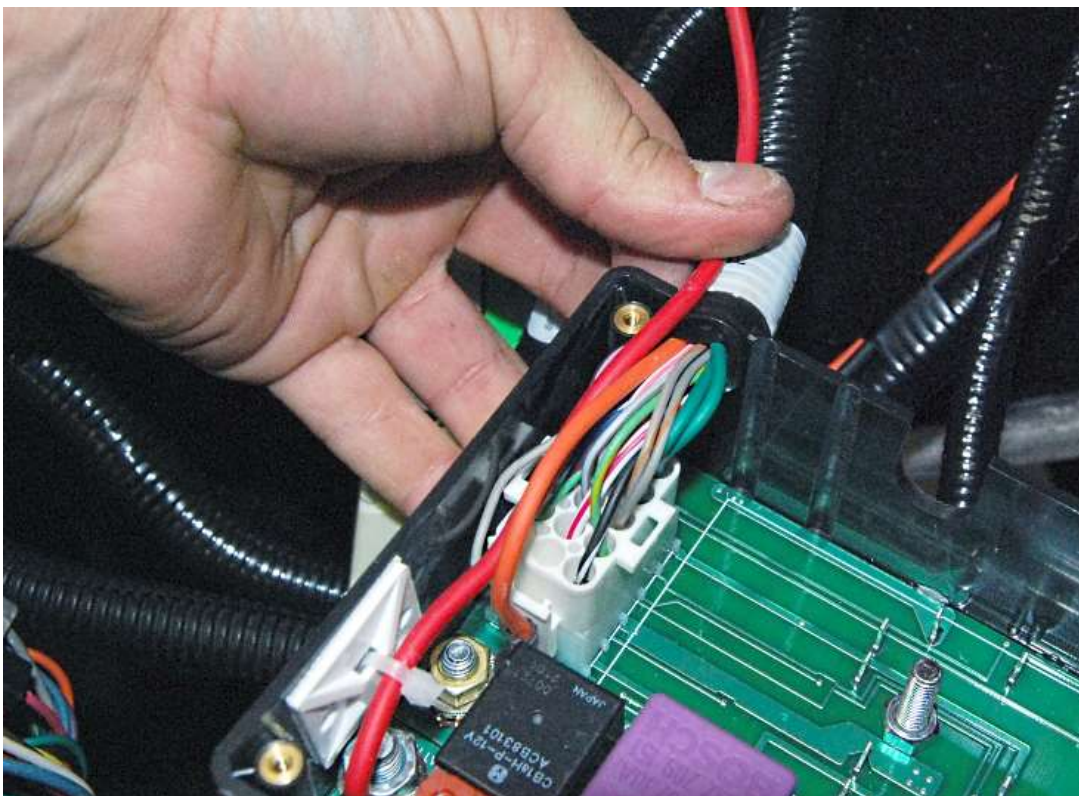

Run the white plug wires and the orange fan plug out of the box in the slot provided near the plug.

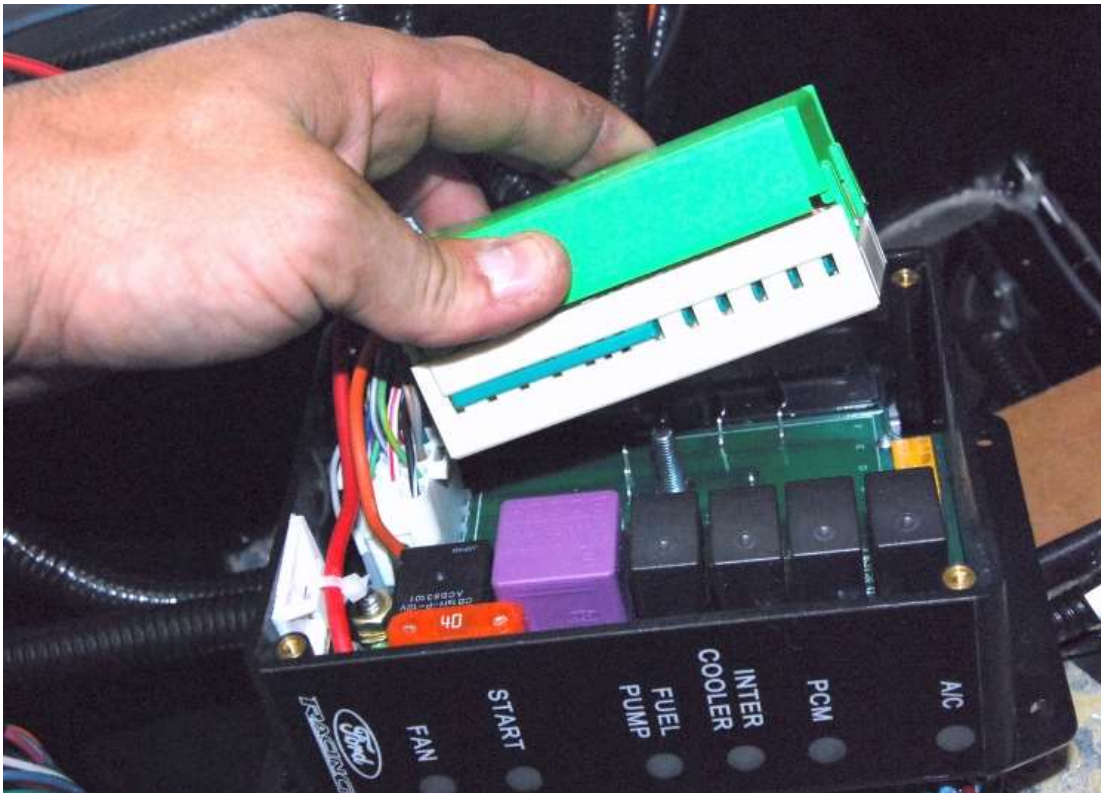

Connect the green power plug inside the box. It gets attached using a large Philips head screwdriver through the bottom of the box.

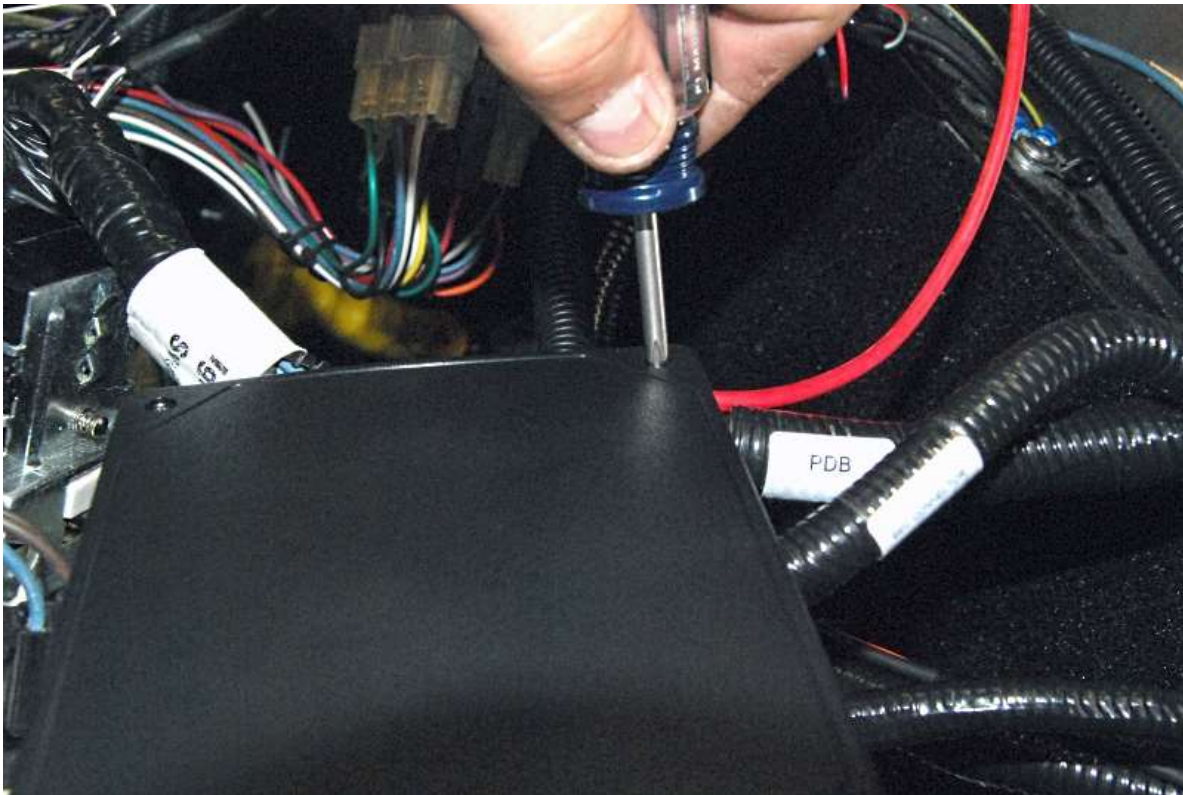

Reattach the top of the box.

Find a location on the frame to mount the box, we suggest to the right of the center of the car on the tubes behind the firewall. If using an A/C unit, there is enough room behind the dash to mount the box to the A/C unit. In the following picture an aluminum piece was used with 1/4" spacers to pick up existing threaded mounting holes and the foot vent area on the A/C unit.



Attach the black box to the frame or mount using some of the self tapping aluminum screws used to hold the aluminum to the frame during shipping.

Fuel Pump



Remove the fuse from the fuel pump circuit on the chassis harness fuse panel.



On the back of the fuse panel, cut the tan wire going from the relay to the fuse area.

Route the Coyote harness fuel pump green wire to the back of the chassis harness fuel panel.

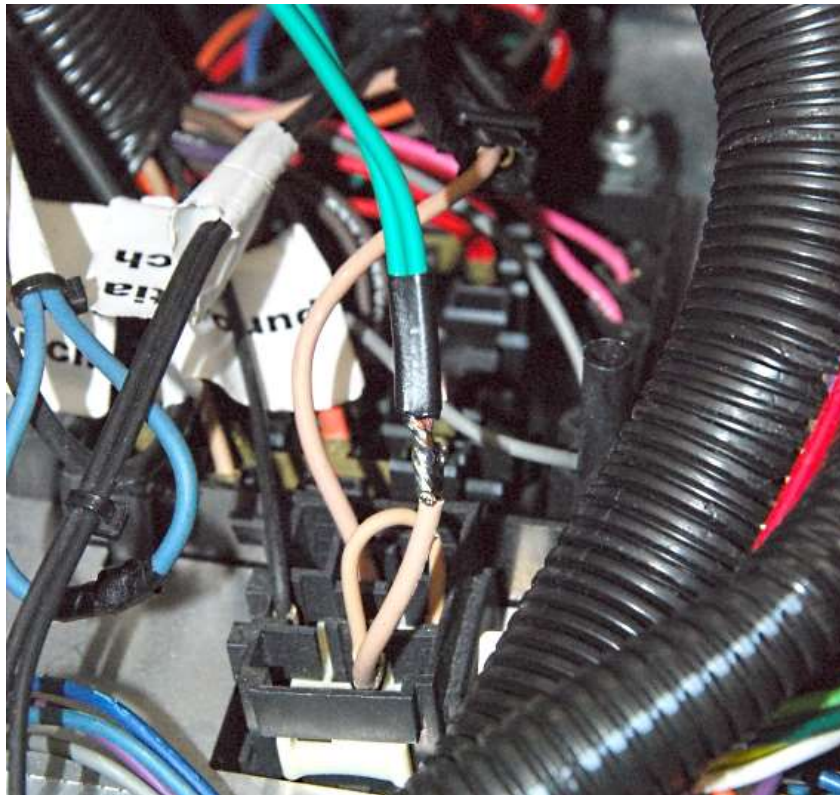

Cut the wire to length and solder the tan and green wires together.

Make sure the wires and harness are out of the way of the steering shaft.

Neutral Safety switch

👉 2011-14 Only

If not using the neutral safety switch in the Coyote harness, route the wire (blue/yellow) to a ground on the chassis.

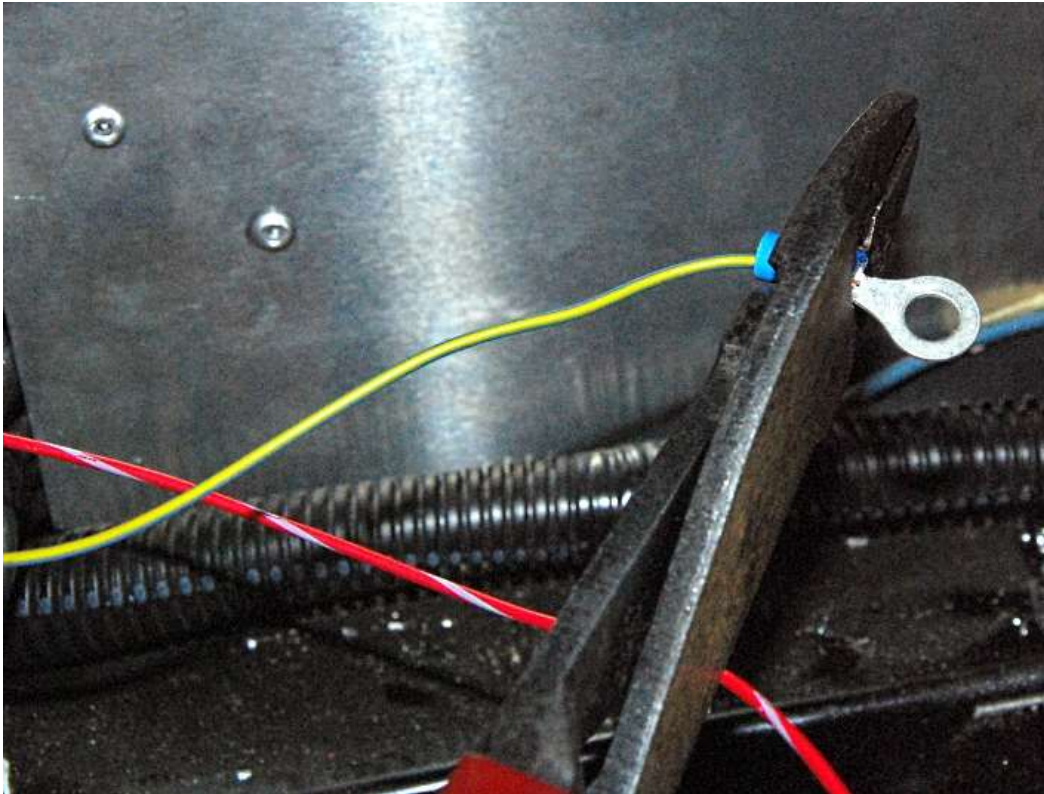

Cut the wire to length and crimp on a blue ring connector.



Attach the ring connector to ground.

Clutch position switches

- 👤 2015 & Newer only
- 🚗 Ford Performance bottom and top travel switches, coyote clutch switch components.
- 🔧 $\frac{1}{4}$ " nut driver, $\frac{1}{2}$ ", $\frac{9}{16}$ " wrench, $\frac{1}{4}$ ", $\frac{1}{2}$ " socket, Ratchet, $\frac{3}{16}$ ", $\frac{5}{16}$ " hex keys.
- 👤 The install is shown outside the footbox for better pictures.

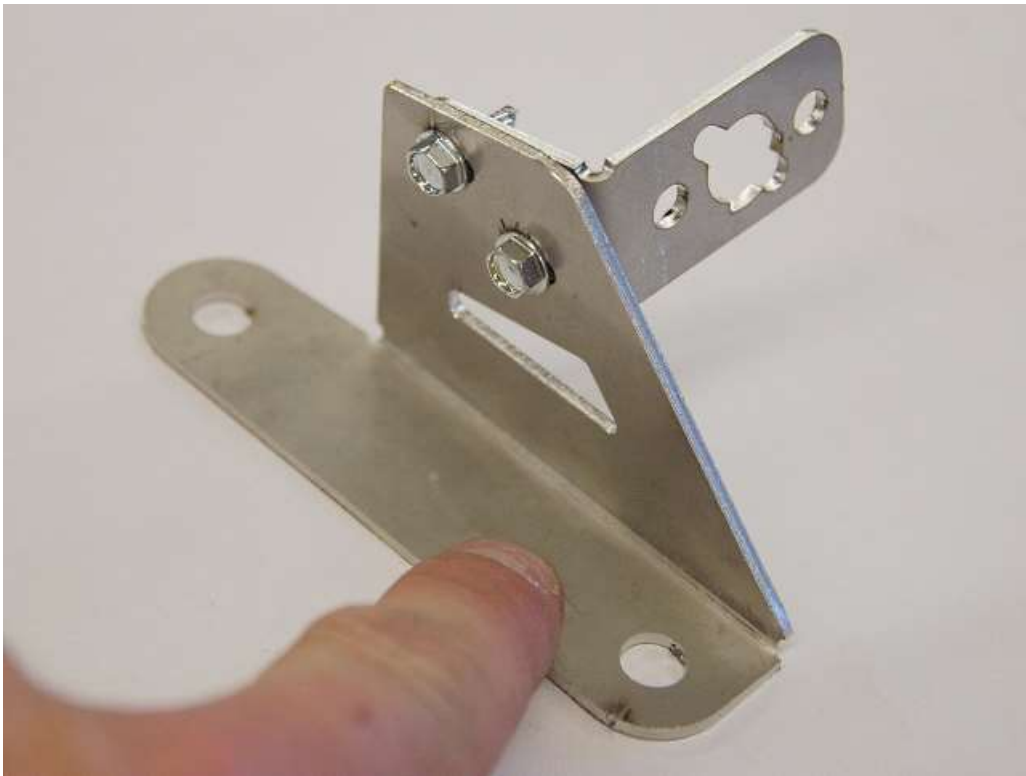

Hold the clutch pedal switch mount in a vise and screw the top travel switch mount to it using the #8 self-tapping screws and ¼” nut driver. Leave the screws loose enough so that the switch mount can slide in the slots.

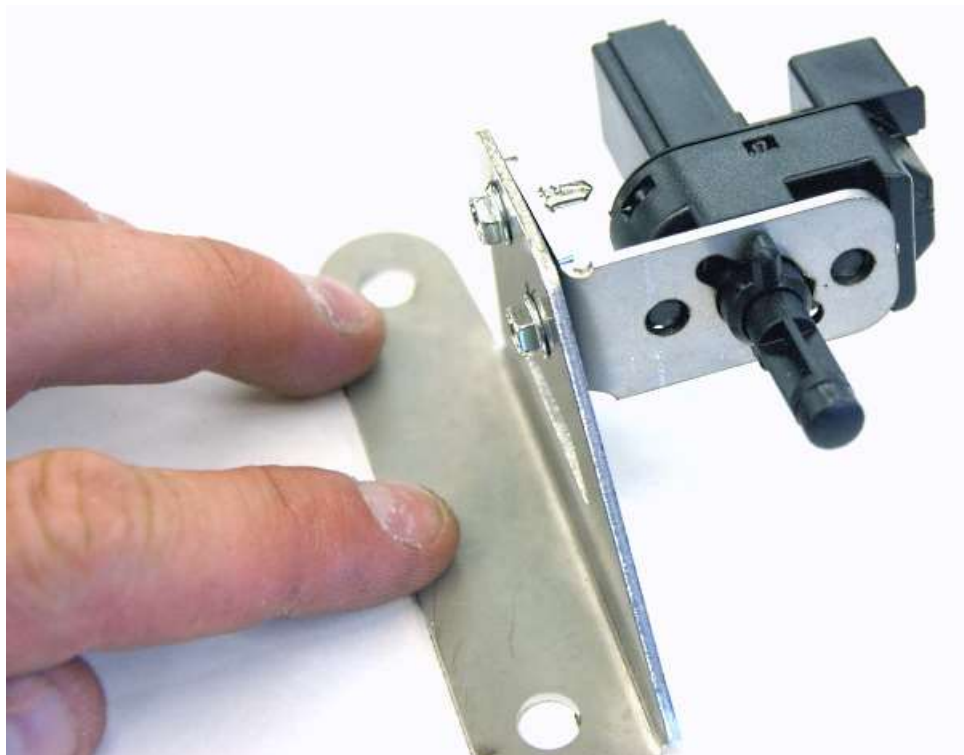

Insert the Top travel (black plunger) clutch switch into the bracket and turn it to the position shown to lock it into place.

Remove the clutch cable from the quadrant.

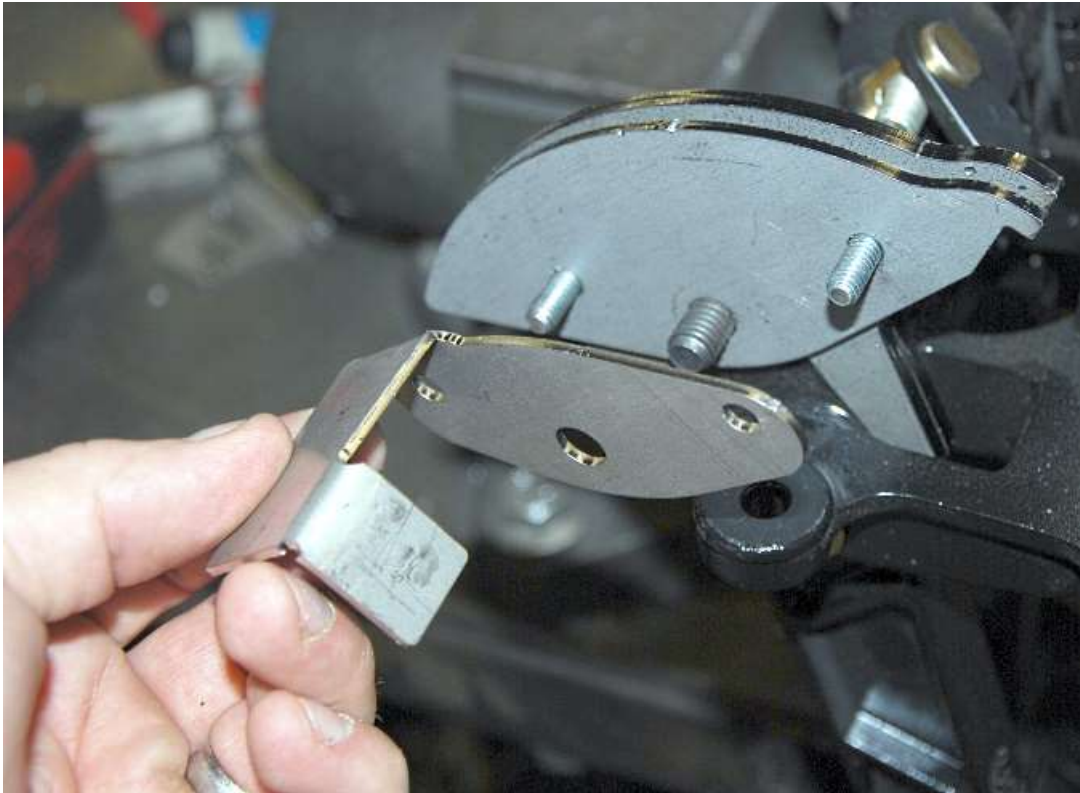

On the clutch pedal, remove the last $\frac{1}{8}$ " clutch quadrant end plate and replace it with the stainless bottom switch clutch quadrant plate.



Tighten the locknuts.

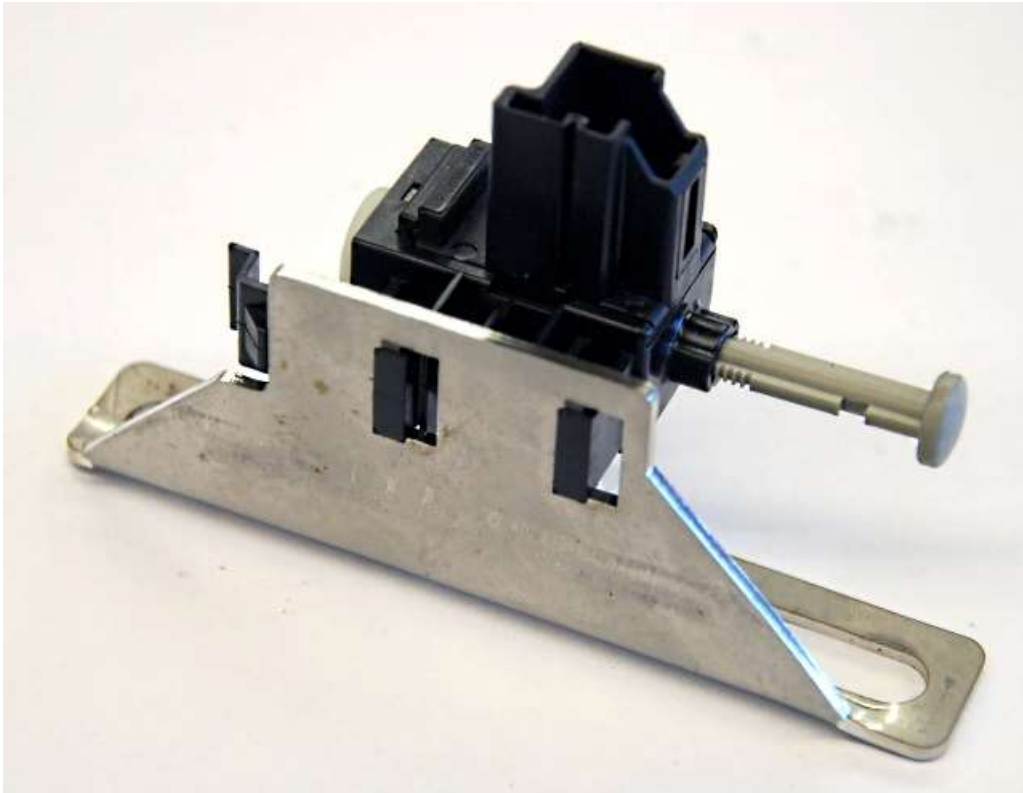

Attach the Bottom travel (gray plunger) clutch switch to the bottom travel switch mount as shown.

Remove the bolts holding the left side of the pedal box to the mount bracket.



Insert the new $\frac{5}{16}$ " x 1.25" bolts through the bottom travel switch mount then through the pedal box bracket and pedal box.



Attach the top travel clutch switch bracket to the bottom of the bolts.

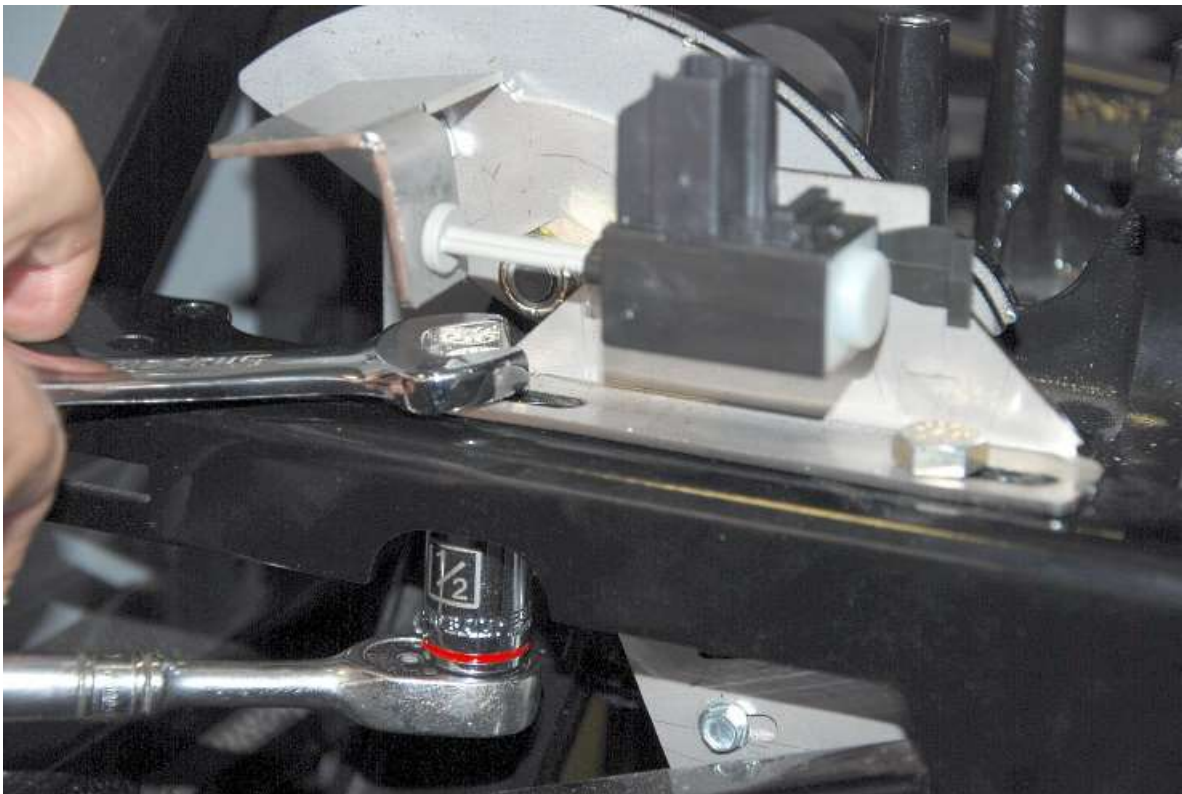

Snug the bolts up with a 1/2" wrench and socket so the bottom travel switch bracket can still move.

Reattach the clutch cable to the quadrant.

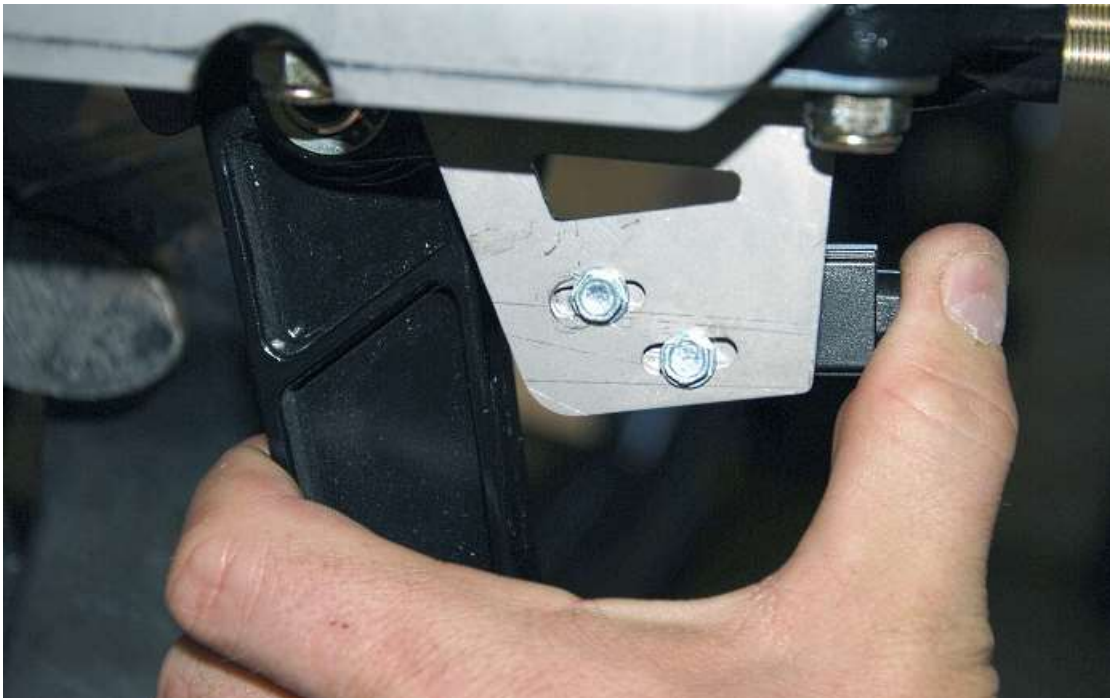

With the clutch pedal in its normal position, push the top travel switch in until it bottoms out on the pedal then tighten the #8 screws with a 1/4" socket and ratchet.

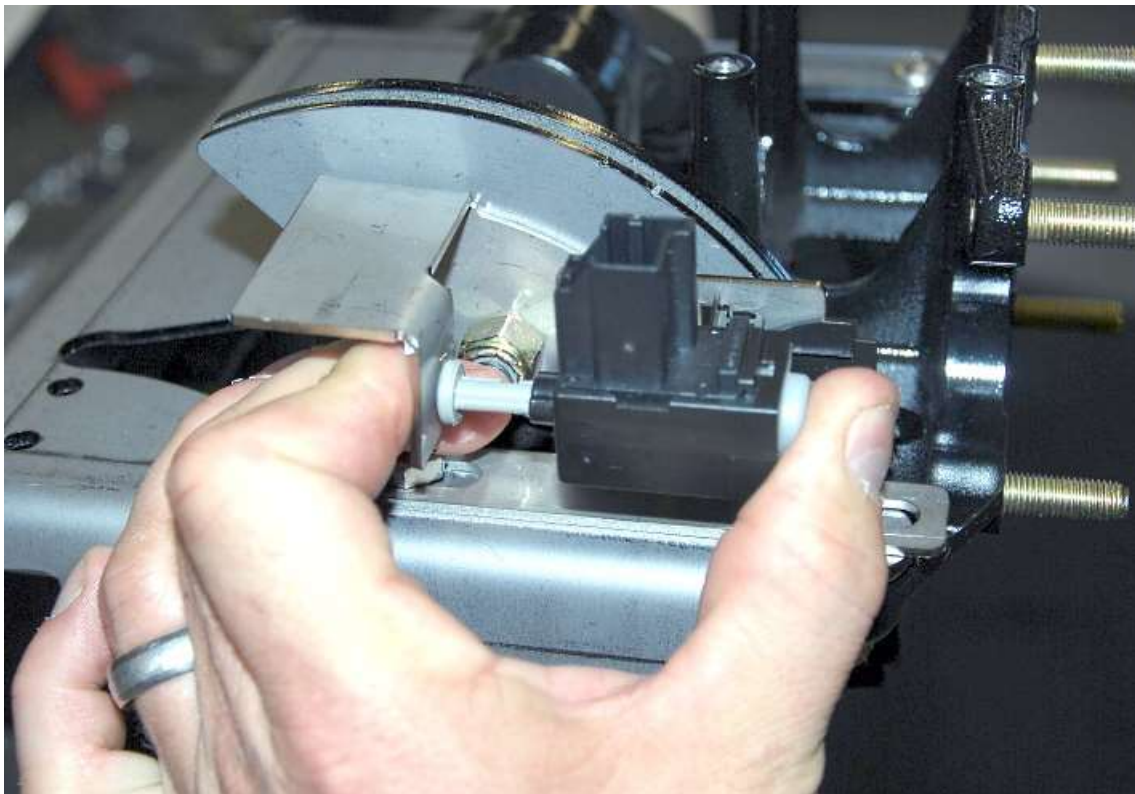

Have someone push the clutch pedal all the way in then slide the bottom travel switch mount so that the bottom travel switch is pressed in all the way against the quadrant plate. Hold the switch mount so that it does not move and let the clutch out then tighten the pedalbox mount screws with a 1/2" wrench and socket making sure the switch mount does not move.

Check the throw of the clutch pedal again carefully. The switches should get pressed in all the way but should not get pushed hard enough to stress/move the body of the switch.

Radiator Cooling Fan

It is best to let the engine control the radiator fan. If you do not want to do this, do not use the wires and remove the correct radiator fan fuse from the black box.



Pull the blue fan wire out of the chasis harness back to the steering bearing mount.



Cut the blue fan wire.

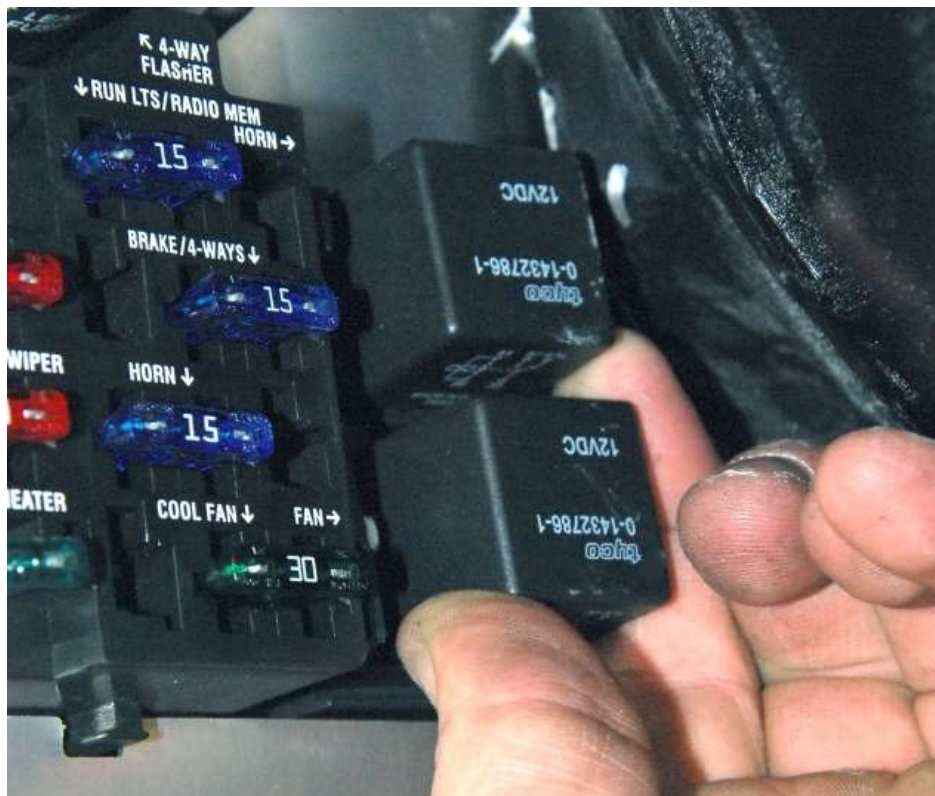

Remove the fan relay from the fuse panel.

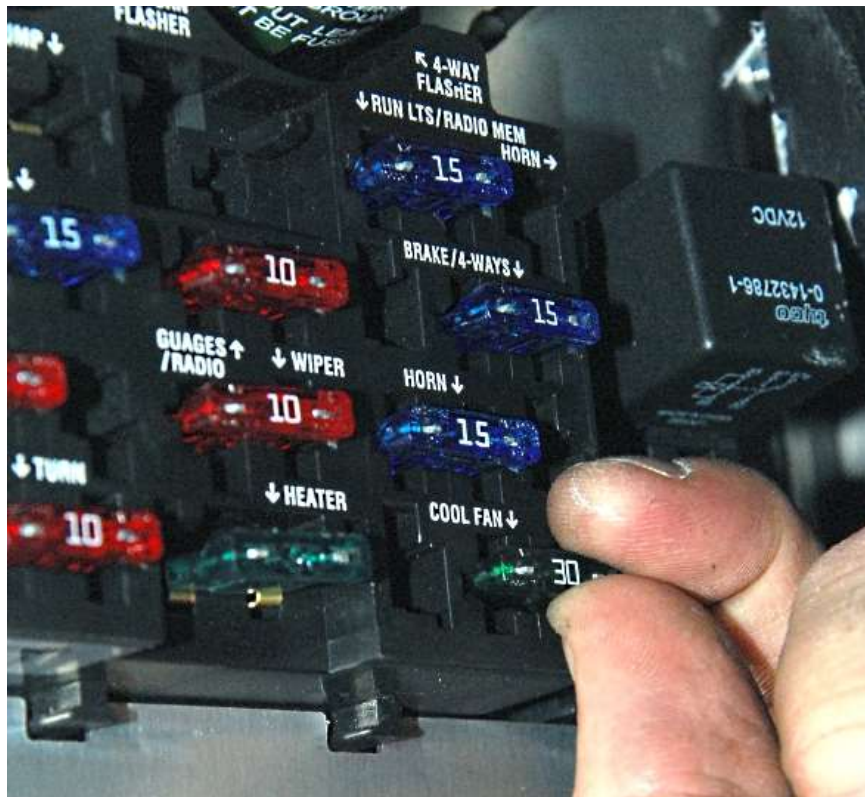

Remove the fan fuse.

Run the orange and black Coyote harness fan wires over to the front chassis harness.

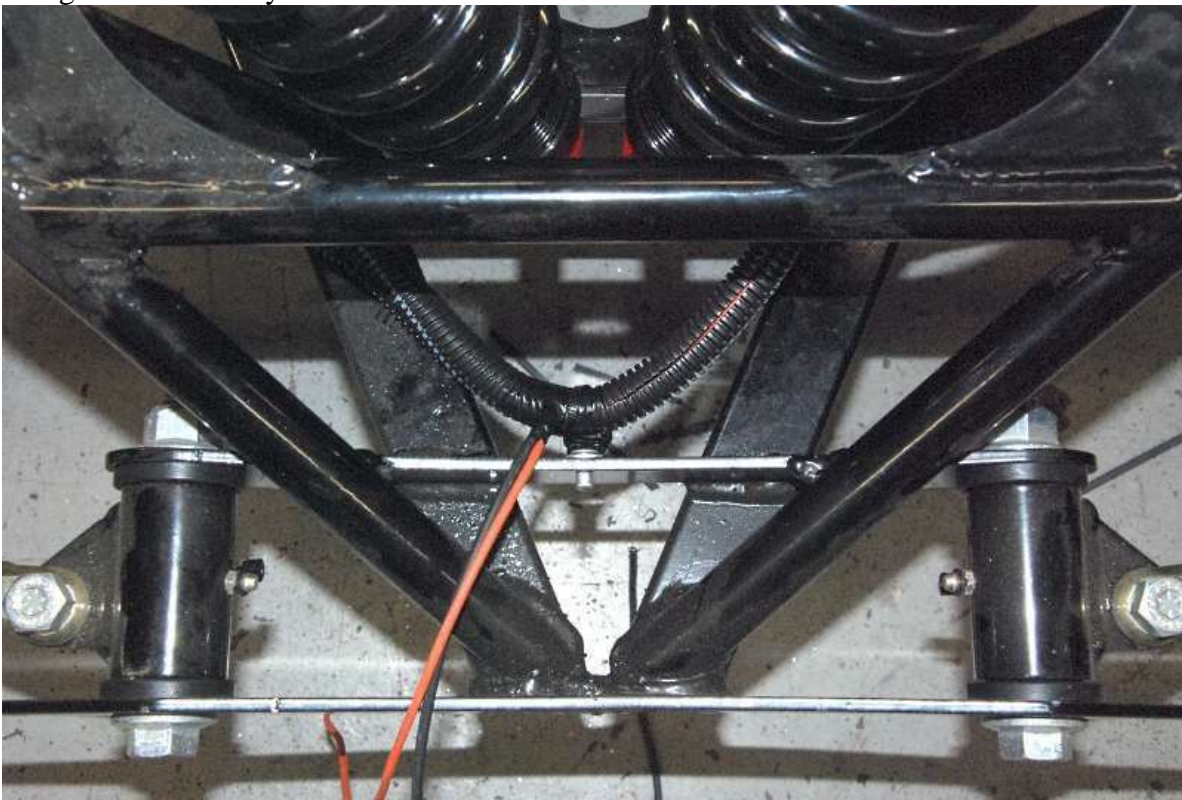

Run the fan wires forward to the front of the frame with the chassis harness.

Power/start

✂ Soldering iron, wire cutters/strippers, electrical tape



Locate the EFI/crank and coil wires in the chassis harness.

2011-2014

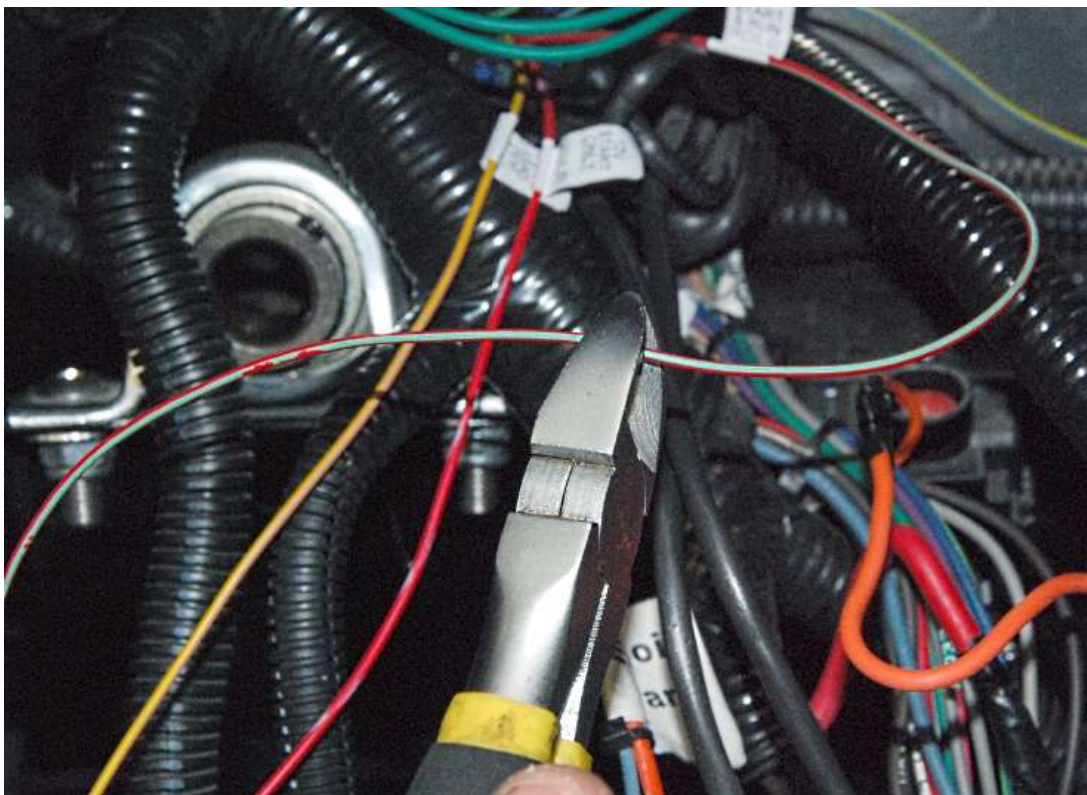

Route the Coyote 12v start/run wire (red/green) and 12v start (red/blue) wires to the chassis harness EFI wires and cut to length.

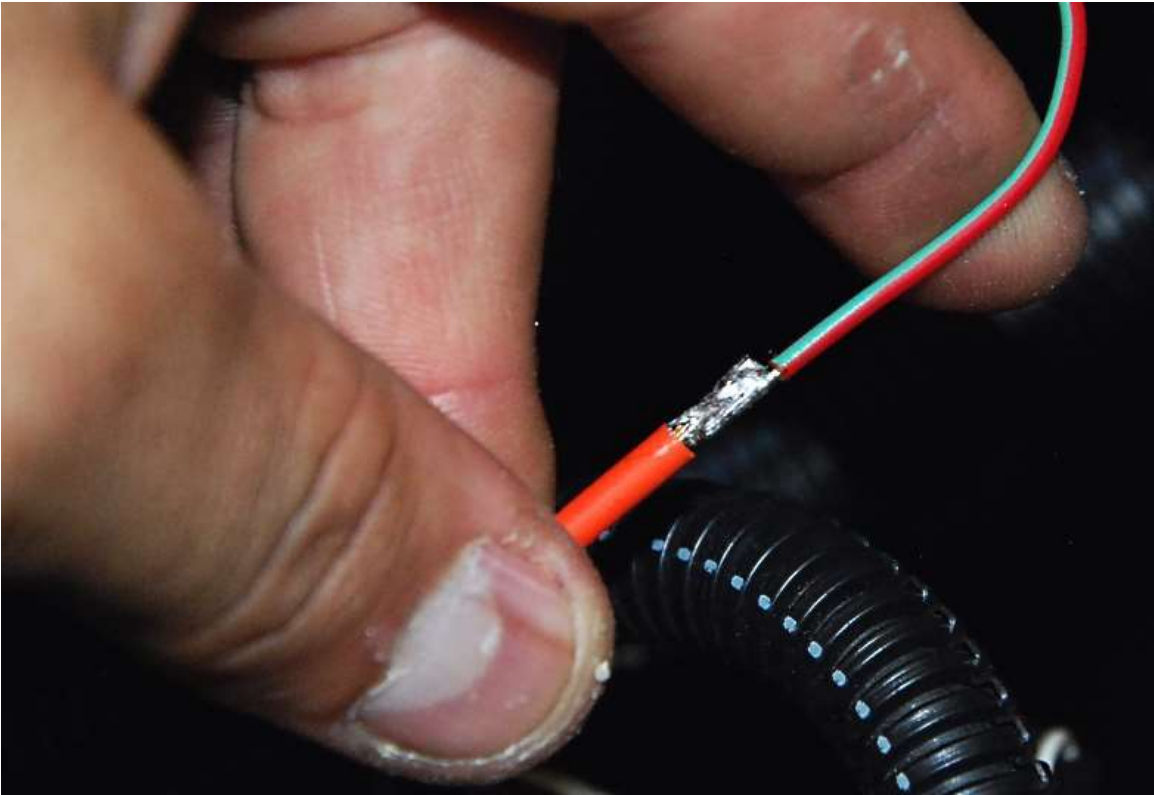

Connect the 12v start/run wire (red/green) wire to the orange coil wire.

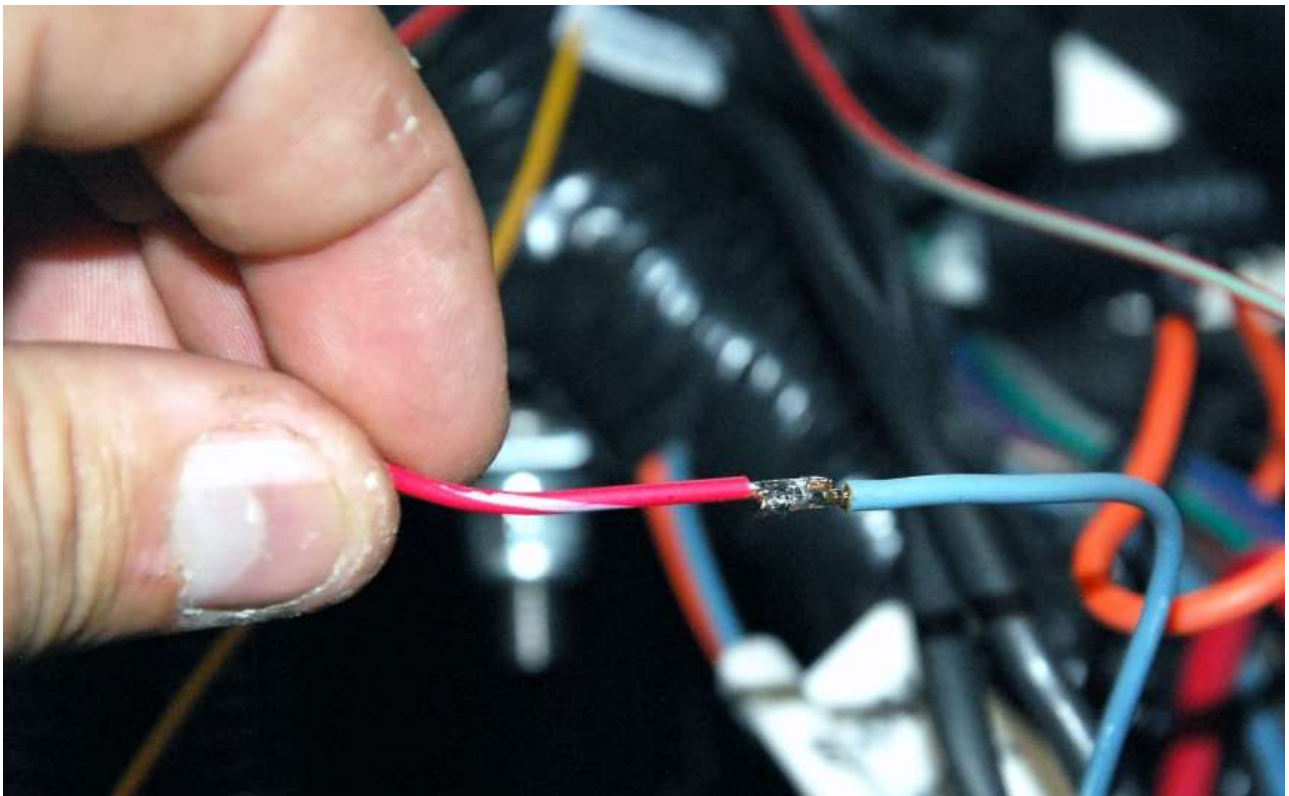

Connect the 12v start (red/blue) wire to the blue crank wire.

2015 & NEWER

- ✂ Soldering iron, wire cutters/strippers, electrical tape

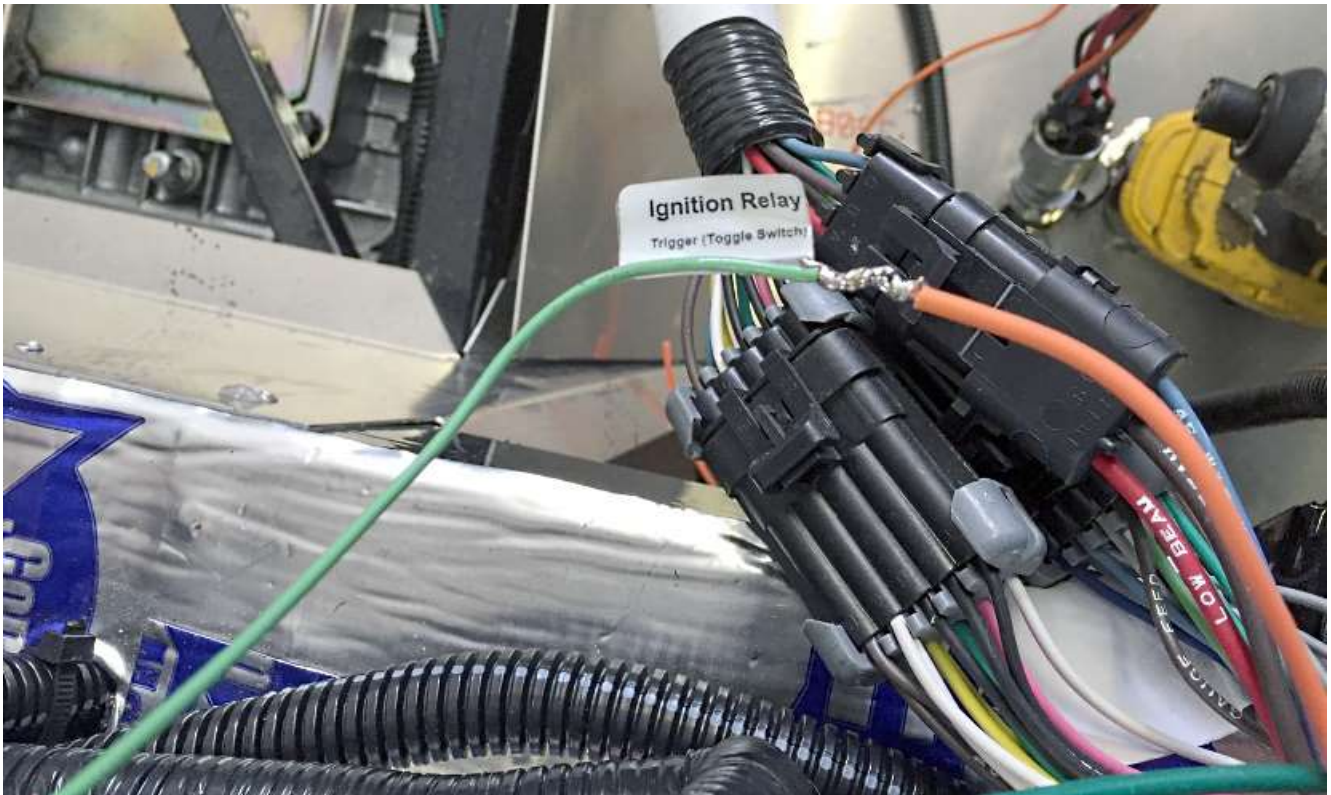

On the 16 way connector, connect the 12v Ignition relay trigger wire (light green) wire to the orange coil wire.

On the 16 way connector, ground the black wire as instructed in the Ford Performance instructions.

On the 16 way connector, do not connect the yellow wire. Doing so will make the engine run after the key is shut off.

👉 No other wires are used from the 16 way connector.

👉 We use the Non-PCM engine starting directions in the Ford Performance instructions. This uses the chassis harness starting wire to engage the starter.



If a neutral safety switch is not going to be used, connect the two blue chassis harness wires together by either soldering the wires or using a butt connector from the “misc. electrical components” assembly in the Factory Five Racing main kit pack.

Starter Solenoid



The solenoid on the starter is the one being used to start the engine.

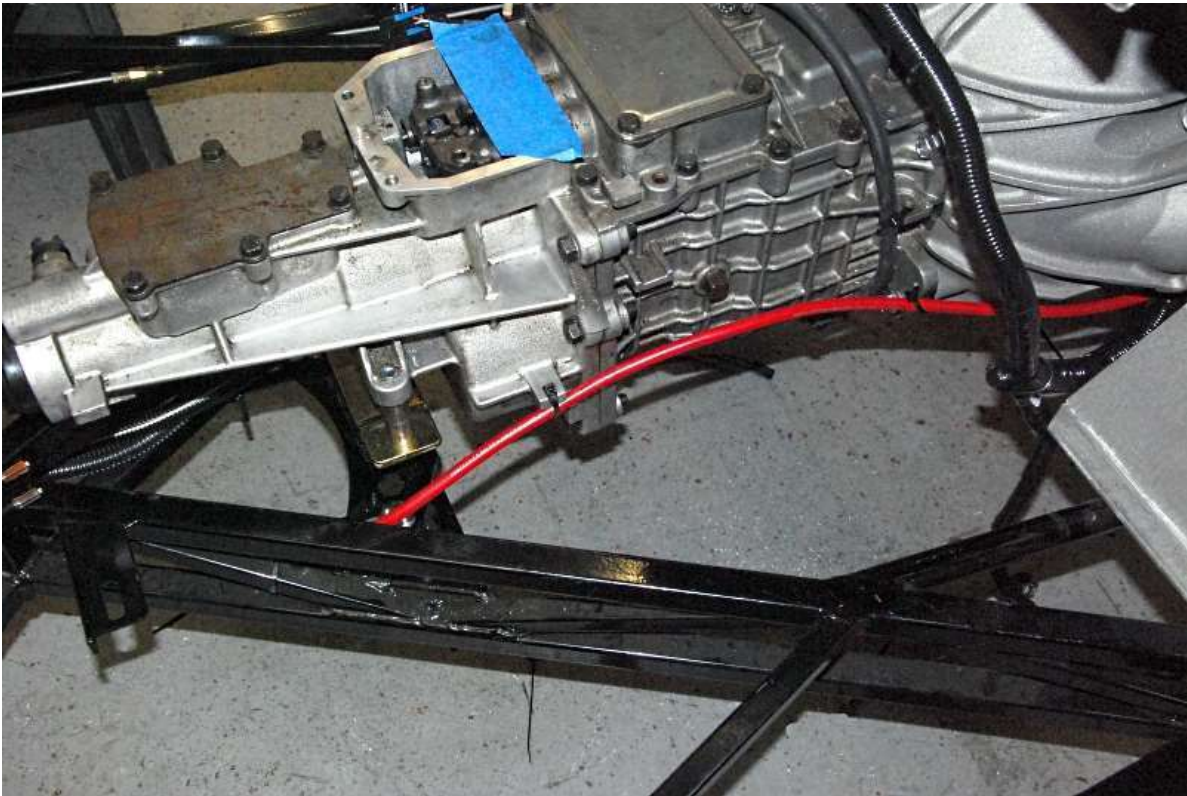

Run the battery cable forward along the transmission from the battery.



Attach the battery cable to the starter solenoid.

👉 Make sure not to push the cable too far over or it may contact the starter post.

2011-2014



Attach the tan/green wire to the starting post on the solenoid.

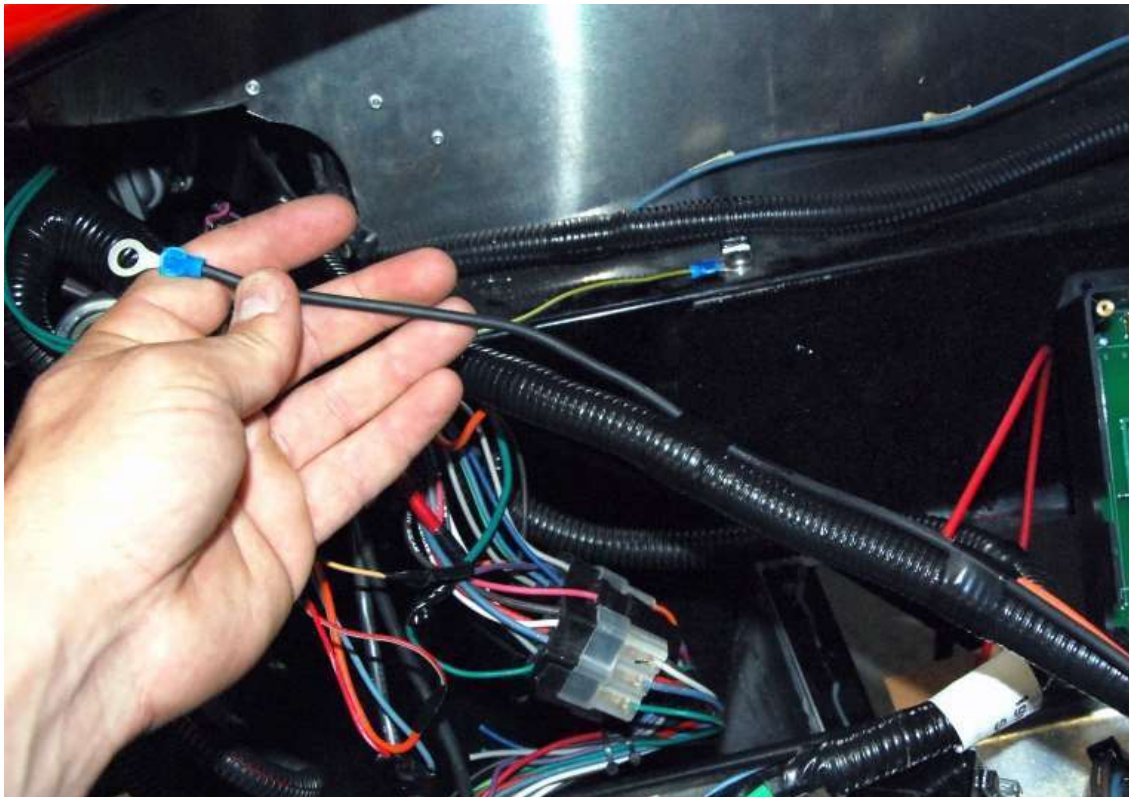

Run the ground wire that exits the harness with the tan/green starter wire over to your engine ground strap ground or some frame ground.

Crimp a ring connector to the ground wire.

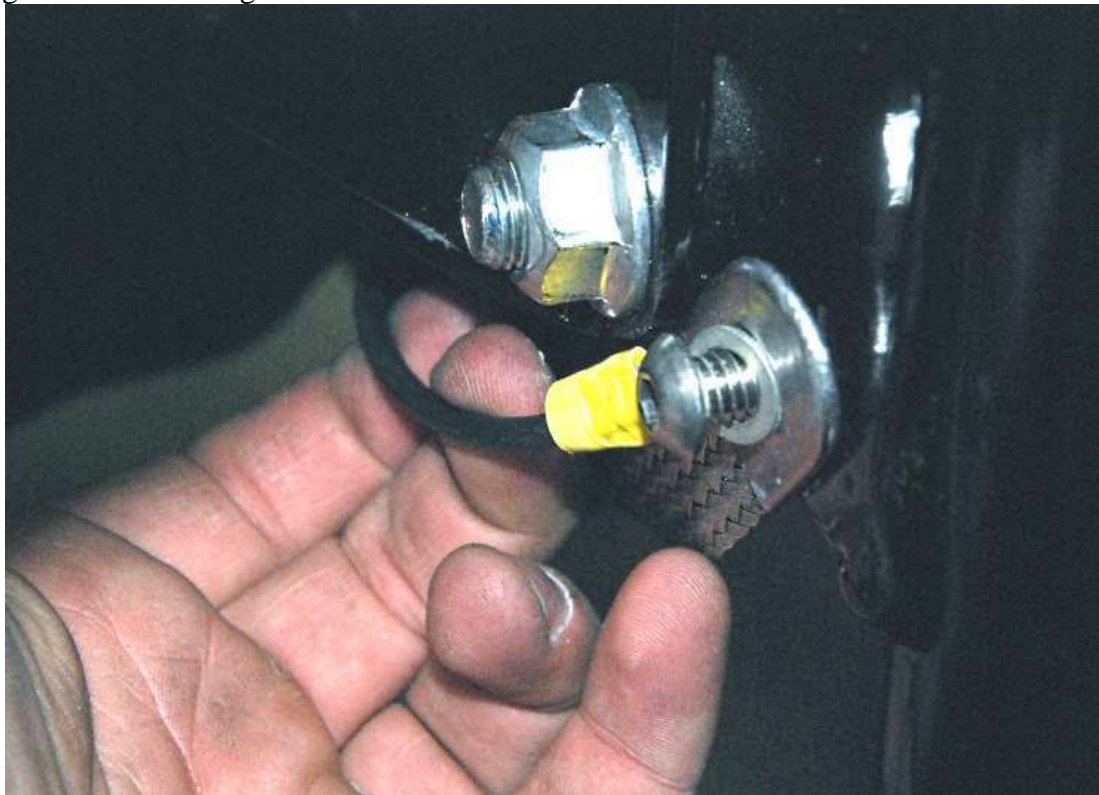

Attach the wire to ground.

Attach the battery cable, starter wire and ground wire to the oil pan with the wiring harness.



Cut the chassis harness blue starter solenoid wire back to the harness conduit.

Use electrical tape to cover the end of the blue wire.

2015 & NEWER

- ✂ $\frac{5}{32}$ " hex key, $\frac{1}{2}$ " wrench, $\frac{1}{4}$ " drill bit, 1" hole saw, drill
- 🔩 $\frac{1}{4}$ "-20 stainless washer head screws, locknuts, expandable grommet, Ford Performance control pack in-line fuse mount and 4ga battery cable.



Locate and mark the inline fuse just to the left of the dash support post on the firewall or on the 2" tube.

If firewall mounting, drill 1/4" holes and use the 1/4" x 0.75" stainless washer head screws, locknuts along with a 5/32" hex key and 1/2" wrench to attach the fuse mount to the firewall.

If mounting the fuse mount to the tube, use the #8 x 3/4" self-tapping screws.

Wire the fuse and harness per the Ford performance "Power distribution Box Installation Instructions".

Drill a 1" hole at the top center of the transmission tunnel then insert the expandable grommet.

Run the positive battery cable connecting to the fuse out of this hole and to the battery side of the starter solenoid on the starter.



Ground the control pack harness to the frame, make sure to remove any frame coating to ensure a good ground.

O₂ Harness

✂ Soldering iron, wire cutters/strippers, electrical tape

2011-14

Locate the right side O₂ wires in the Coyote harness near the bellhousing.



Zip tie the harness forward to the harness going to the computer.

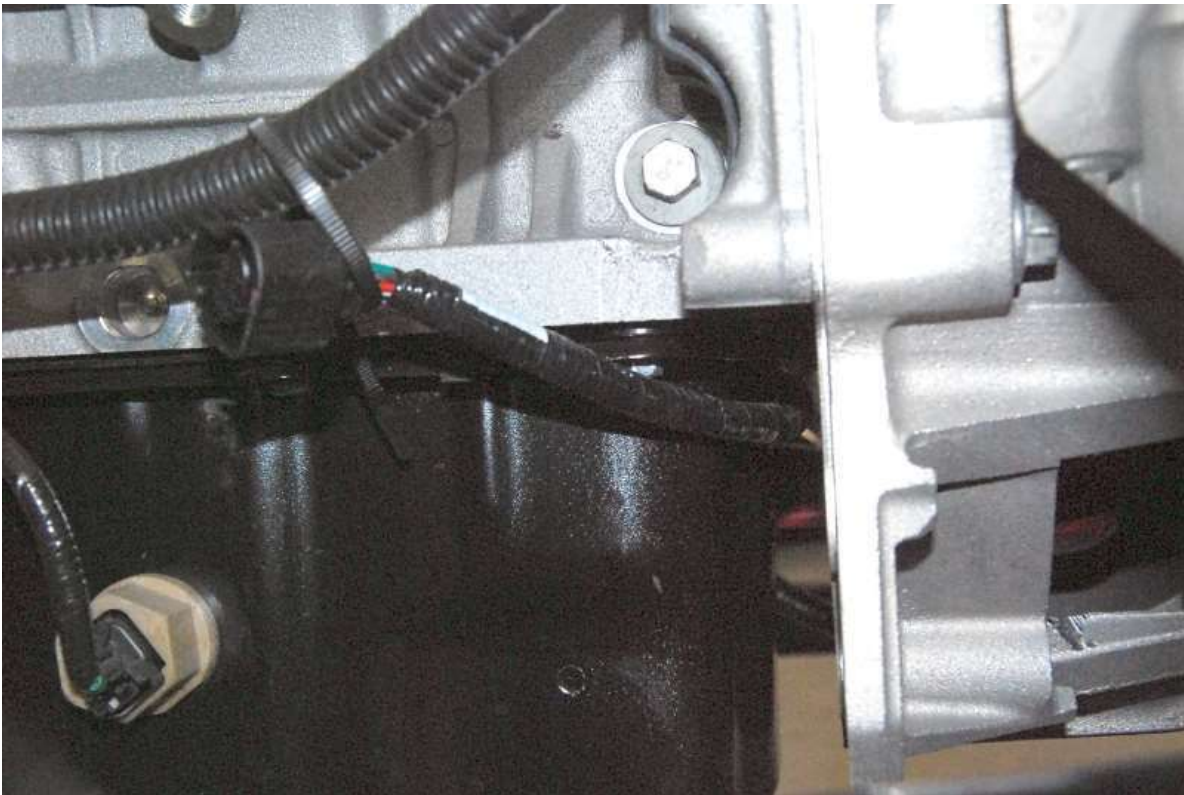

Run the left side O₂ wires between the oil pan and bellhousing over to the left side of the engine.

2015 & NEWER



Attach the right O₂ sensor to the connector at the back of the head.





Connect the left O₂ sensor to the connector down near the engine mount

Intercooler wire



Cut the white/red Intercooler pump wire as far back in the harness as you can. It is not needed or used.

Power Distribution

-  Wire cutters/strippers, electrical tape, wire crimpers.
-  We used an extra starter solenoid for power distribution in these instructions. A distribution post is provided in the Coyote kit.
-  The solenoid on the starter is the one being used to start the engine.

Locate and attach the power distribution post to the 2"x 2" tube.

Shorten and attach the red wire from the black box to the power distribution post using one of the yellow ring connectors.

Attach a ring connector to the 10 ga red wire.

Attach the 10 ga wire ring connector to the post.

Run the 10 ga wire to the battery side of the starter solenoid on the engine.

Cut the wire to length and attach another yellow ring connector.

OBD 2 Port

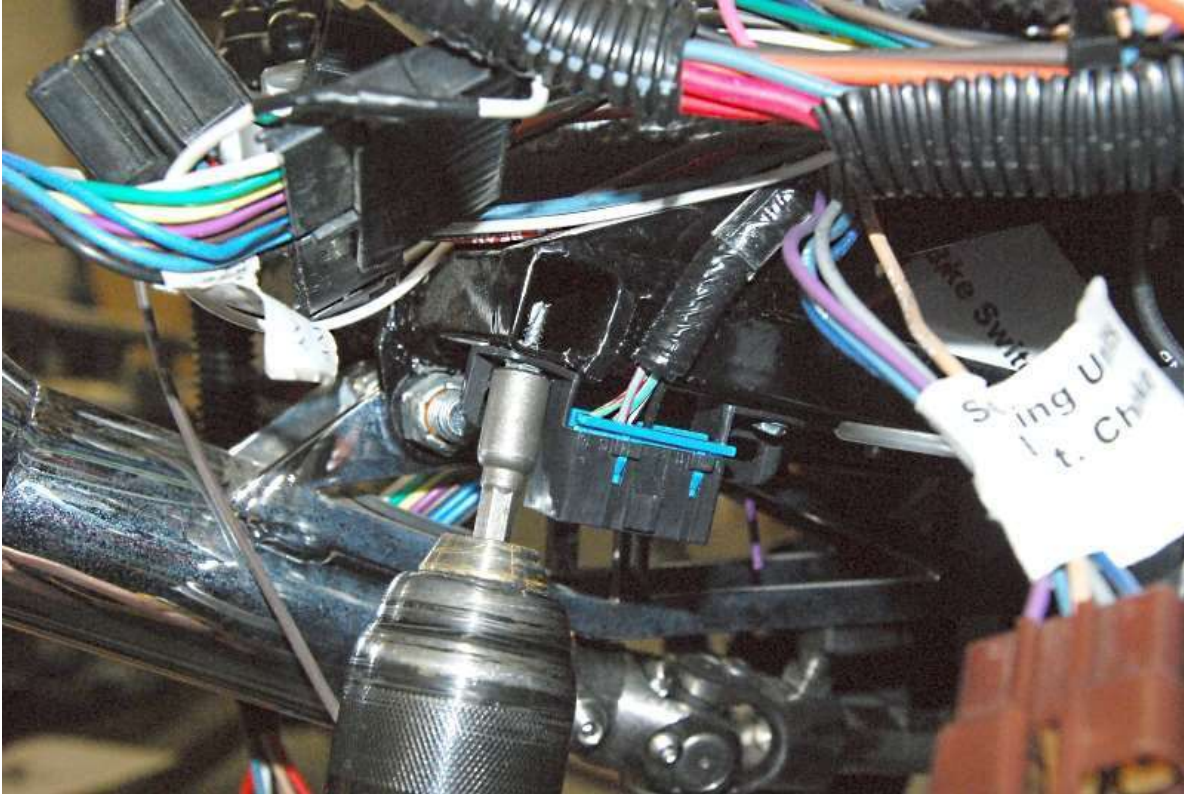

Use some of the aluminum panel #6 screws to attach the OBD 2 plug to the frame.

Gauges

TACH

✂ Soldering iron, wire cutters/strippers, electrical tape

2011-2014

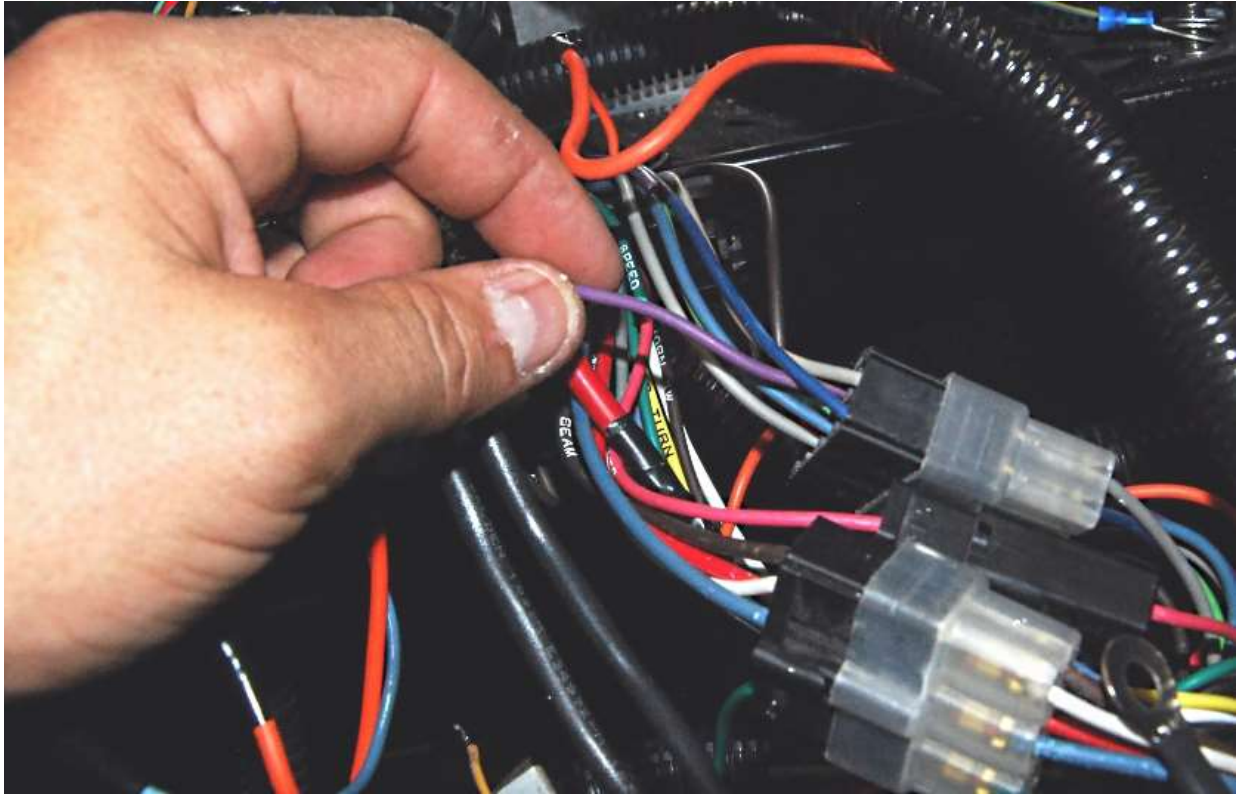

Find the purple tach wire in the sending unit plug and cut it so the engine harness can get connected to the purple wire.

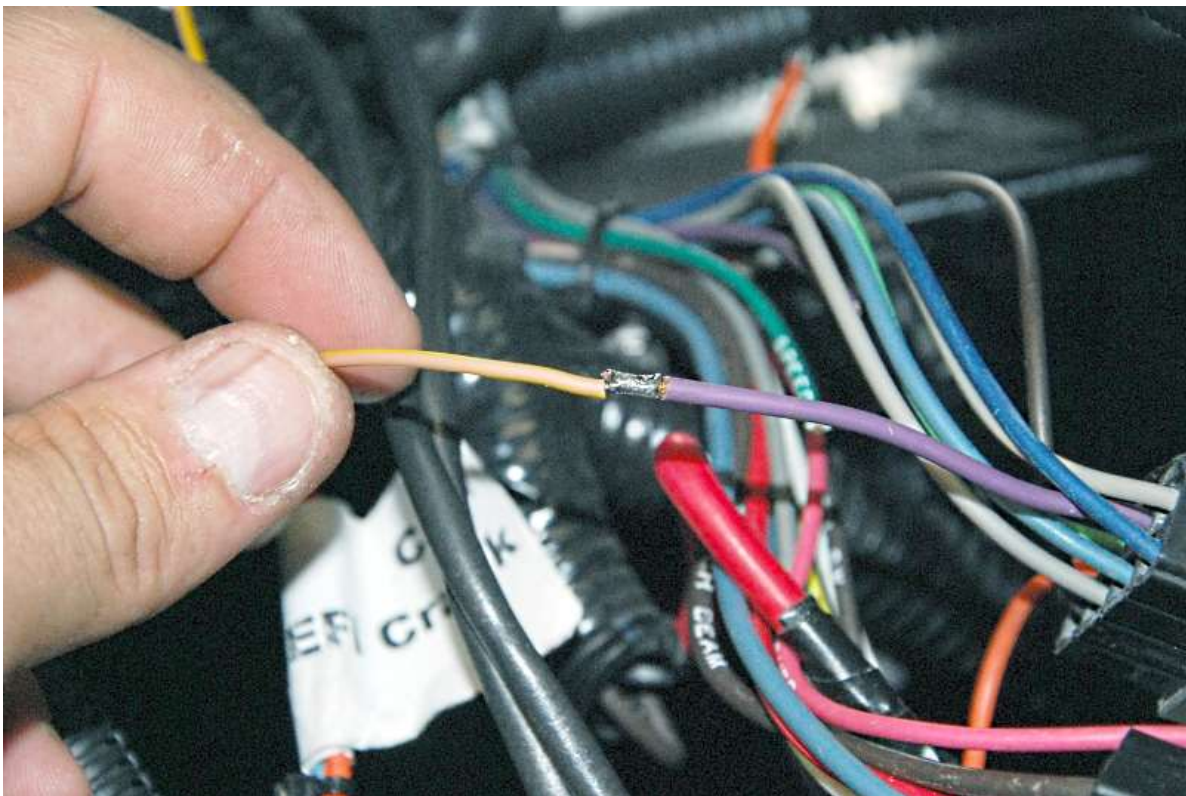

On 2014 or older Coyote engine harnesses connect the tach wire to the chassis harness plug and connect it to the purple wire attached to the plug.

For 2015 Coyote engines and newer there is no tach wire in the engine harness. The tach will need to get connected to a coil wire as shown in the gauge instructions.

2015 & newer

There is no tach wire in the engine harness. The tach will need to get connected to a coil wire as shown in the gauge instructions according to the #3 Coil on plug description.

WATER TEMP SENDER

✂ Wire cutter, wire crimper, $\frac{3}{8}$ " wrench



Run the blue water temp chassis harness wire to the sending unit and cut to length.



Crimp a ring terminal to the sending unit wire.



Attach the ring terminal to the water temp sending unit.

OIL TEMP SENDER

✂ $\frac{3}{8}$ " , $\frac{11}{16}$ " wrenches, Wire cutter, wire crimper



Push the Engine/computer harness plug onto the stock sending unit.

Run the chassis harness gray oil pressure wire to sending unit and cut to length. Crimp on a blue ring terminal connector.



Rotate the sending unit so the computer sending unit is facing the rear of the engine.



Attach the sending unit wire ring terminal to the sending unit.

Alternator

- ✂ 10mm, 13mm, (2) 17mm wrenches, 10mm socket, ratchet, wire stripper, wire crimper
- 🚗 Alternator, Alternator drive kit
- 👤 The stock Alternator is designed to run counter clockwise and the frame goes through the stock location so it can not be used. With the internal fan curve direction of the stock Alternator, there is a possibility that the Alternator could overheat when run in the opposite direction.
- 👤 The Honda alternator runs clockwise and when run in the orientation we use it is run the correct way.

ITEM NO.	PART NUMBER	DESCRIPTION	QTY.
1	33824	ALTERNATOR MOUNT BRACKET	1
2	HONDA ALTERNATOR		1
3	33828	1.18" SPACER	1
4	33827	1.00" SPACER	2
5	33825	3.37" SPACER	1
6	33826	3.48" SPACER	1
7	hex cap screw_cm	M10-1.5mm x 110mm HEX HEAD CAP SCREW	1
8	B18.2.3.1M - Hex cap screw, M10 x 1.5 x 65 --263		1
9	M10F	NUT NYLOC M10 TYPE F	1
10	hex cap screw_cm	M8-1.25mm x 140mm HEX HEAD CAP SCREW	2
11	B18.2.3.1M - Hex cap screw, M8 x 1.25 x 80 --22N		1

REV.	REVISION DESCRIPTION	DATE	APPROVED
A	INITIAL RELEASE	1/20/15	

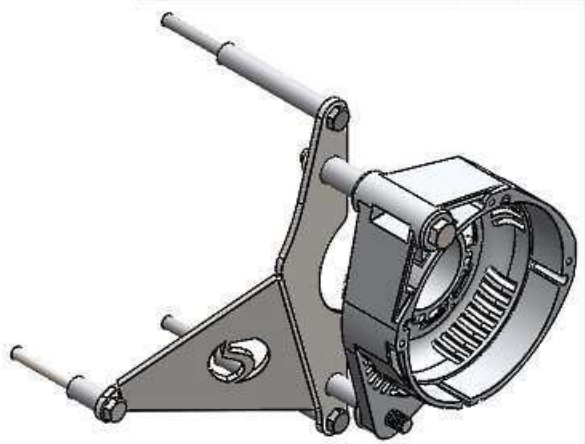
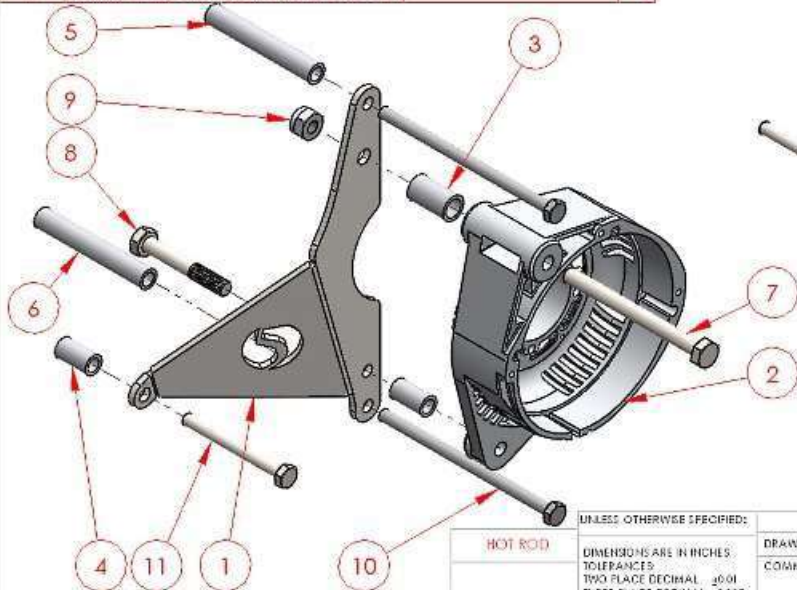

PROPRIETARY AND CONFIDENTIAL
 THE INFORMATION CONTAINED IN THIS DRAWING IS THE SOLE PROPERTY OF FACTORY FIVE RACING, INC. ANY REPRODUCTION IN PART OR AS A WHOLE WITHOUT THE WRITTEN PERMISSION OF FACTORY FIVE RACING, INC. IS PROHIBITED.

UNLESS OTHERWISE SPECIFIED:		NAME	DATE	 Factory Five Racing, Inc.
DIMENSIONS ARE IN INCHES		JI	2/5/15	
TOLERANCES		DRAWN		
TWO PLACE DECIMAL .001		COMMENTS		
THREE PLACE DECIMAL .0005		TITLE:		
FOUR PLACE DECIMAL .0001		HOT ROD COYOTE ALTERNATOR DRIVE		
MATERIAL		SIZE	DWG. NO.	REV
FINISH		A	33830	A
APPLICATION:	PRINTED	SCALE: 1:3		WEIGHT:
	1/20/2016			SHEET 1 OF 1



Put the large long bolt through the alternator and place the spacer on the bolt.

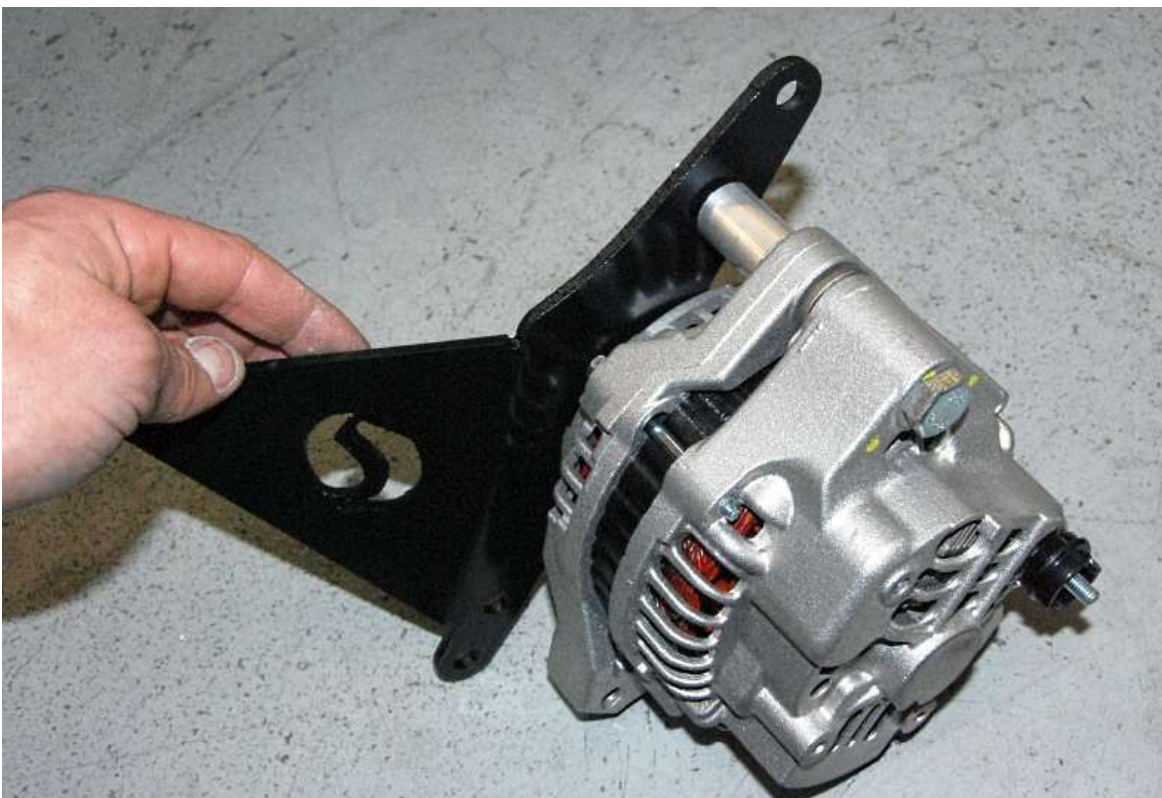

Attach the alternator to the mounting bracket leaving the nut so that the alternator can rotate.

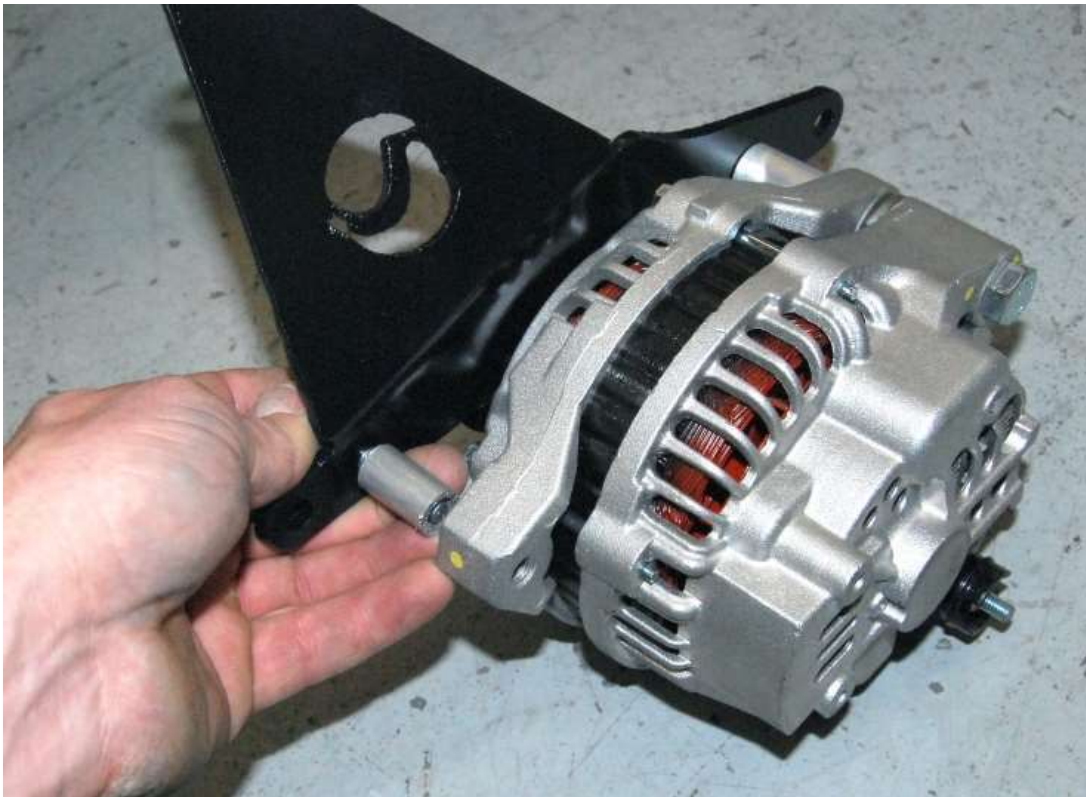

Pass the short bolt through the other bracket mounting hole and place the small ID spacer on the bolt.

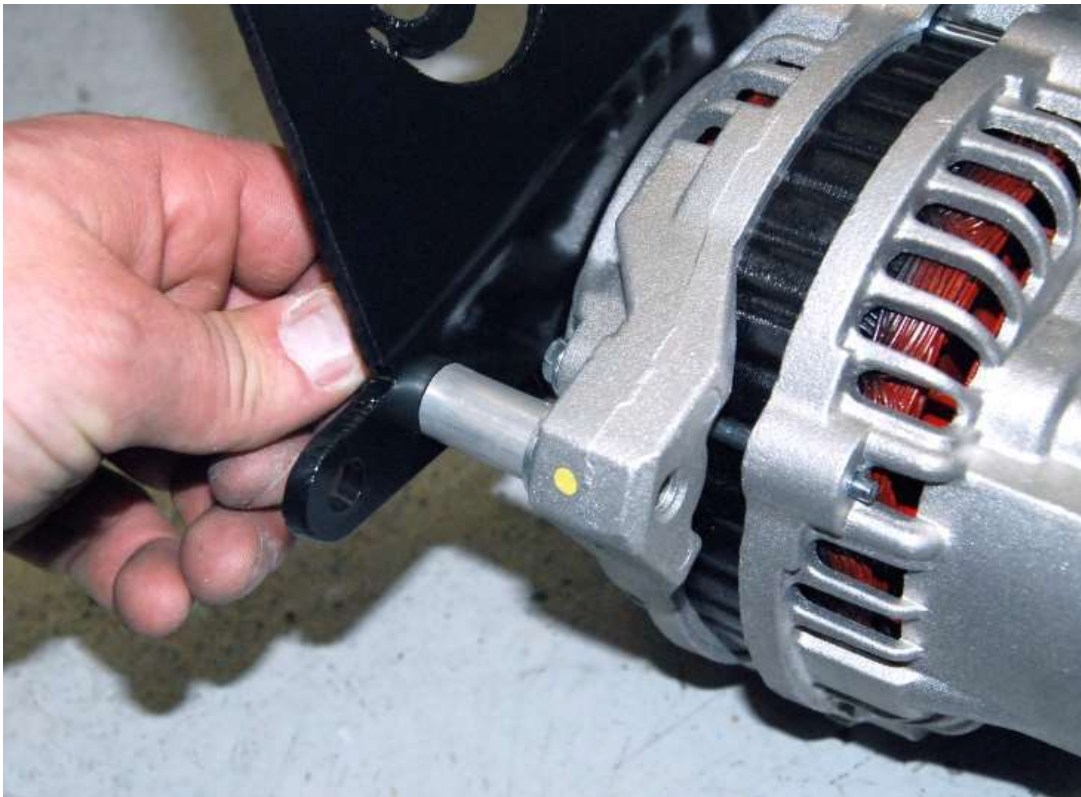

Thread the bolt into the Alternator.

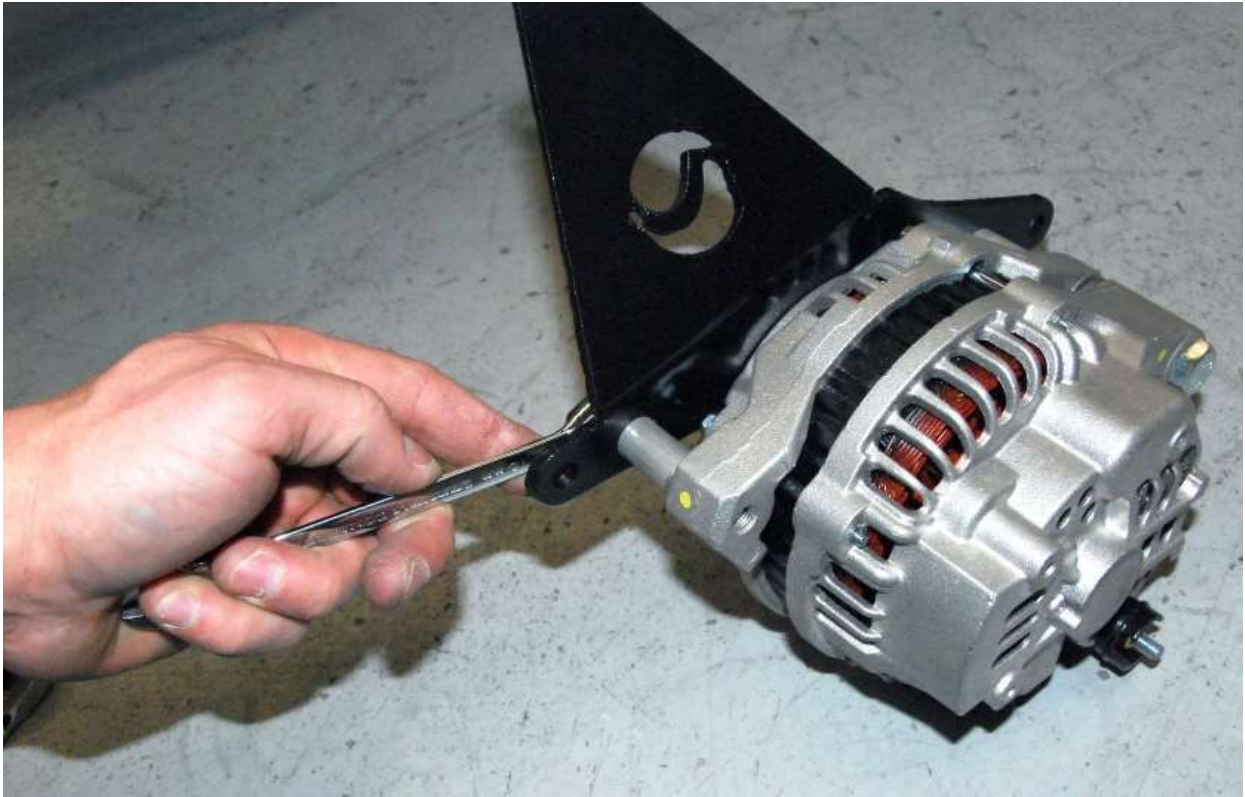

Tighten the alternator mounting bolts.



Run the bracket mounting bolts through the bracket and put the spacers on the bolts.

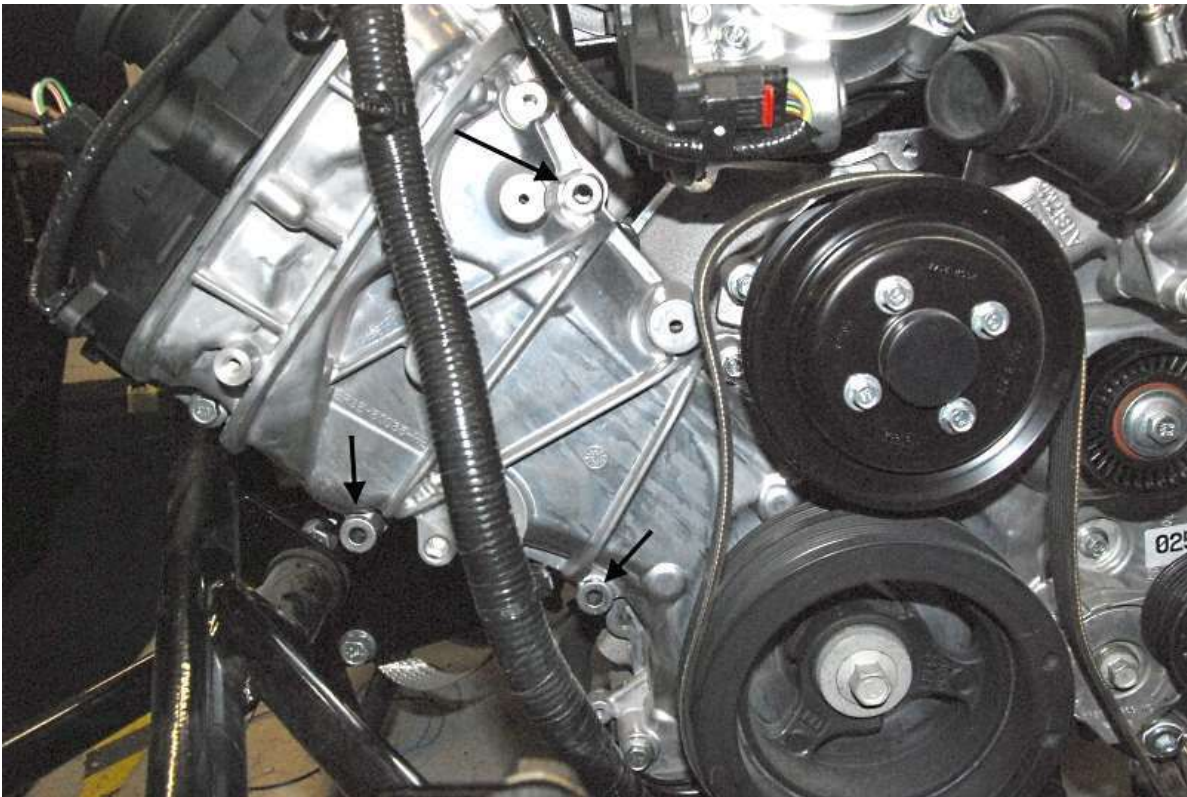

Remove the timing cover screws at the points shown in the picture above.



Attach the mounting bracket to the engine keeping the engine control harness behind the bracket. Belt Tensioner



Ratchet, 15mm socket, vise.

The bolt holding the pulley is left hand thread, do not turn it the wrong way.



Remove the bolt holding the pulley and remove the smooth pulley.



Replace the smooth pulley with the ribbed pulley included. Do not use the metal cover from the smooth pulley.



Attach the belt tensioner to the timing chain cover and tighten to 18 lbft (25Nm) then route the belt as shown.

WIRING



Run the red chassis harness alternator wire under the firewall up to the right side of the engine.



Run the alternator wire to the front of the engine next to the engine harness.

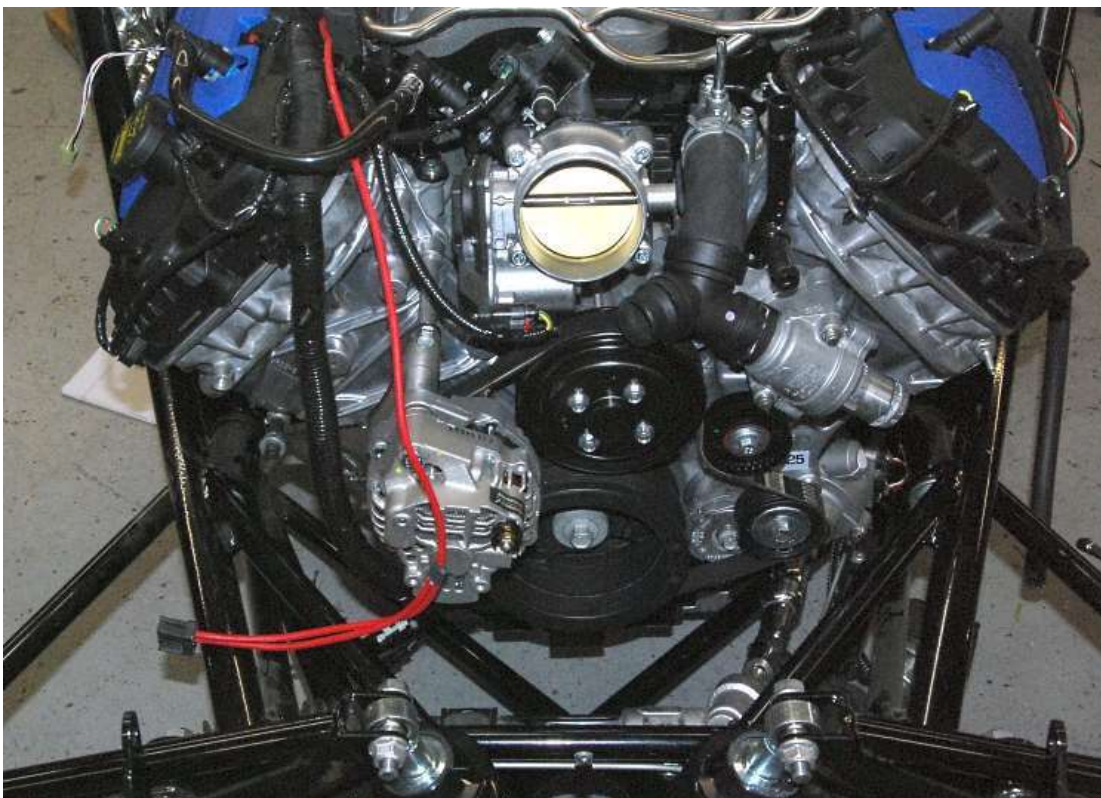

Run the alternator wire down to the alternator output post.

Cut the wire to length and attach a yellow ring terminal connector.

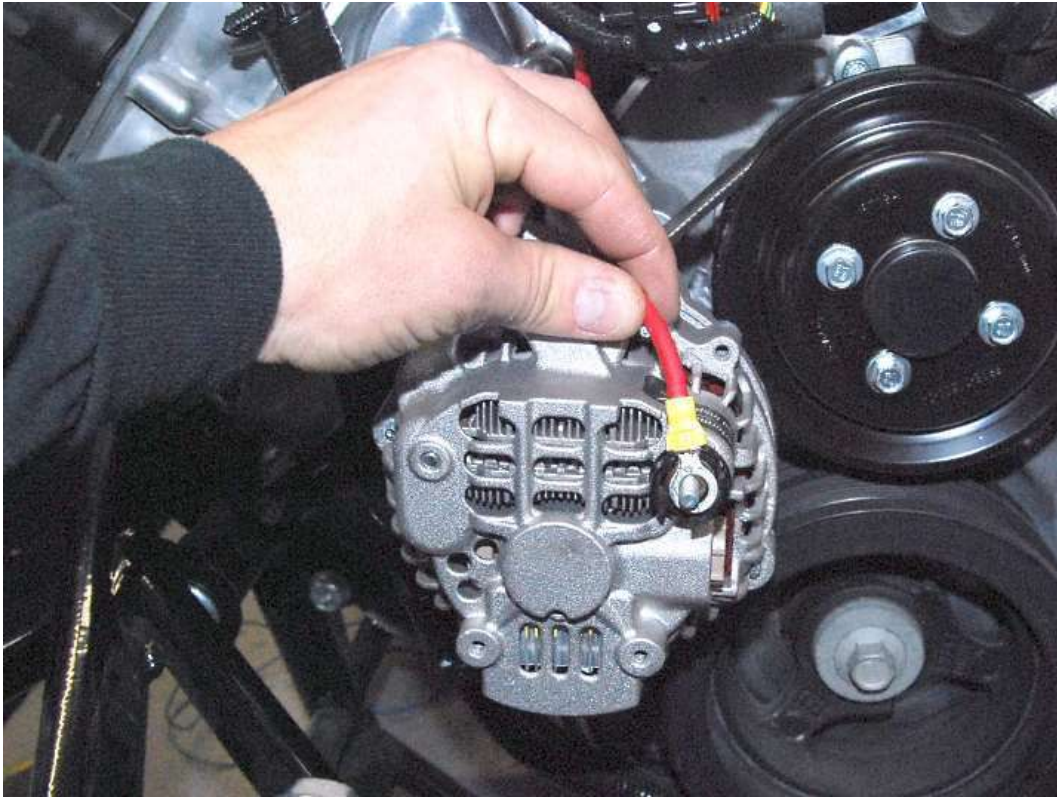

Put the ring terminal on the alternator output post.

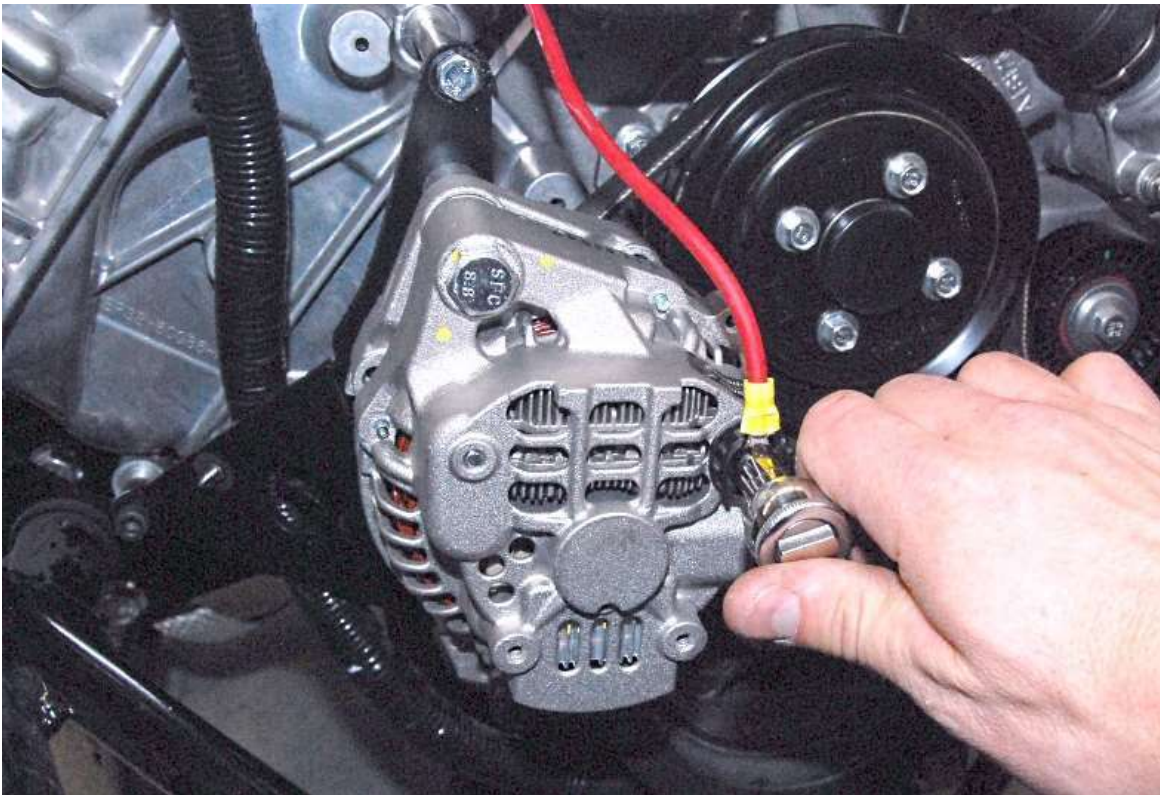

Tighten the locknut on the output post so that the nut is snug. Do not over-tighten or the post might break.



If a dash charge indicator light is desired, run a wire from the “Lamp” connector back to a dash light that is grounded on the other side of the light. Locate the Coyote harness yellow alternator wire (VBAT Monitor) and run it to the Alternator plug. Cut the wire to length.



Test fit the small connector in the Alternator. If necessary, cut off part of the blue covering so that the connector will fit.



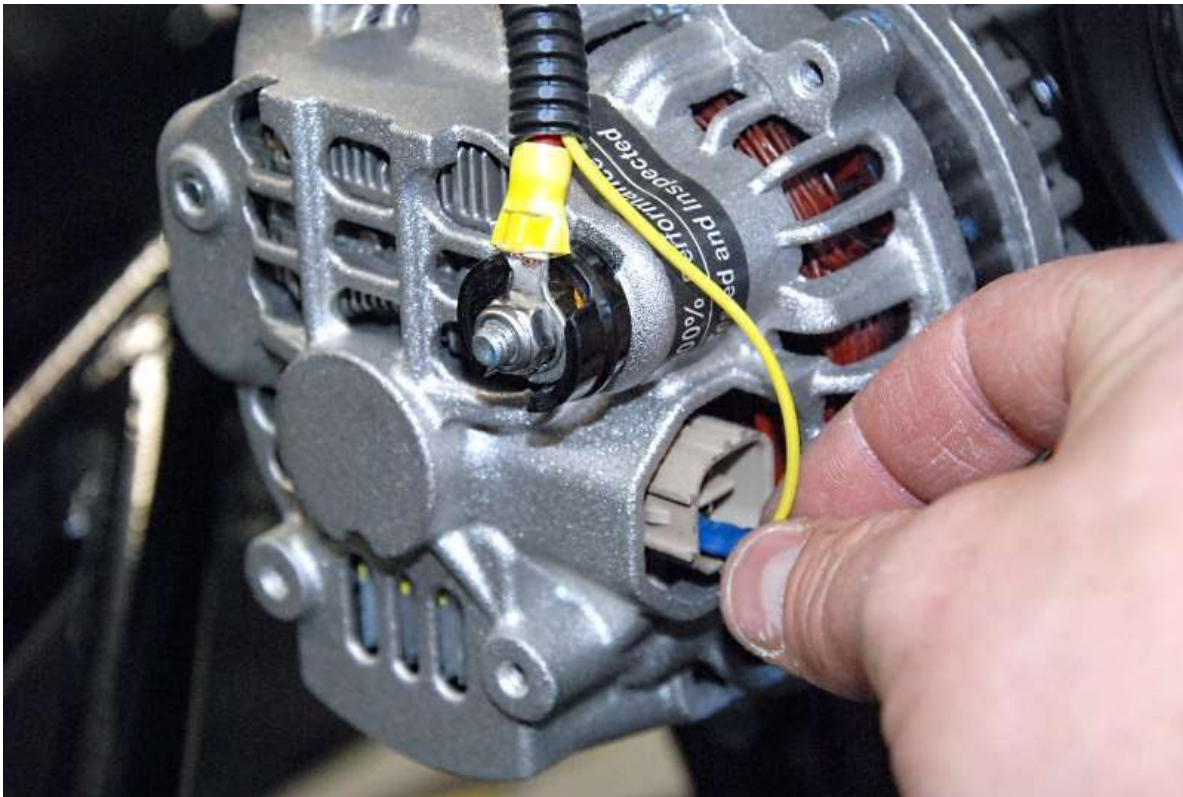

Crimp the small blue connector onto the yellow wire.



Connect the wire to the “Ignition” connector on the Alternator.

Air Intake

Mass Air Meter

-  Mass air meter, silicone hoses, intake tubes, air filter
-  T-20 Torx driver, Flat head screwdriver, Philips head screwdriver, sensor safe RTV silicone
-  These instructions show the Spectre parts. For the Treadstone MAF tube, make sure the Mass Air meter is pointed in the correct direction.



Unscrew the mass air sensor from the Ford intake using a T-20 Torx driver



Remove the sensor and note the direction of the curved part of the sensor.



Install the rubber ring into the intake mount.

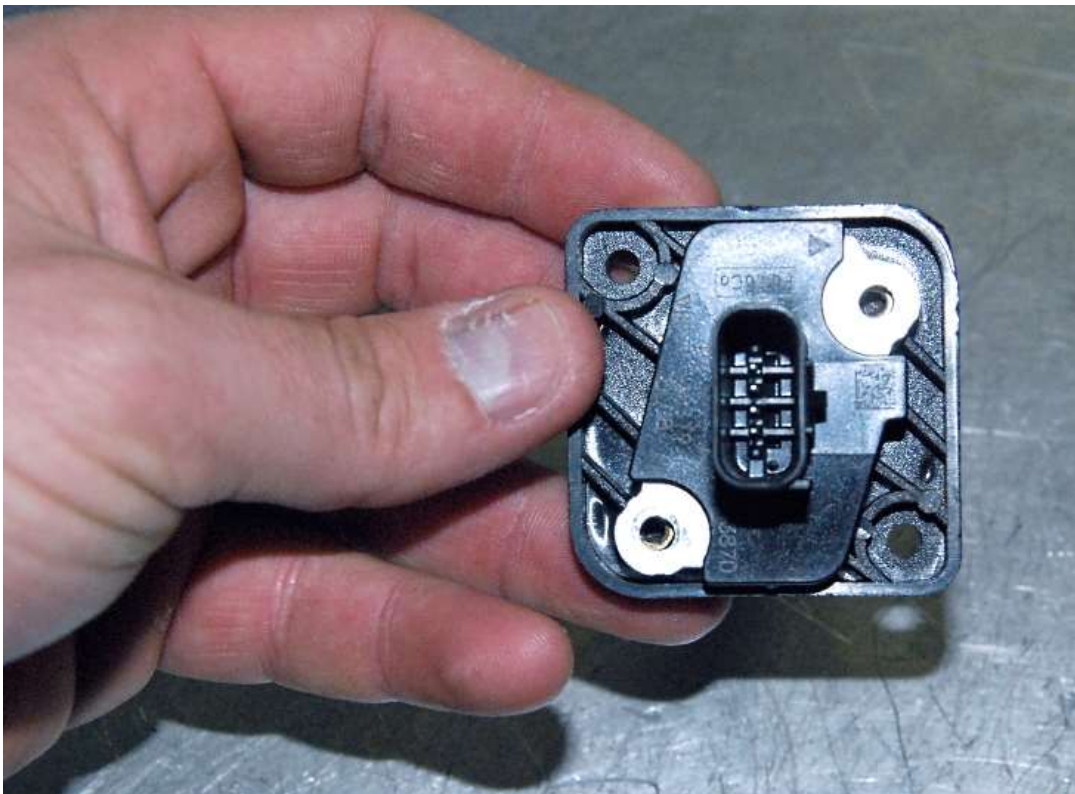

Insert the sensor into the mount to determine which way around it needs to go so the sensor mount holes will line up and the sensor will mount the correct way.



Attach the mount to the intake tube using the long screws so that the flat side of the sensor will face the “Spectre” writing.

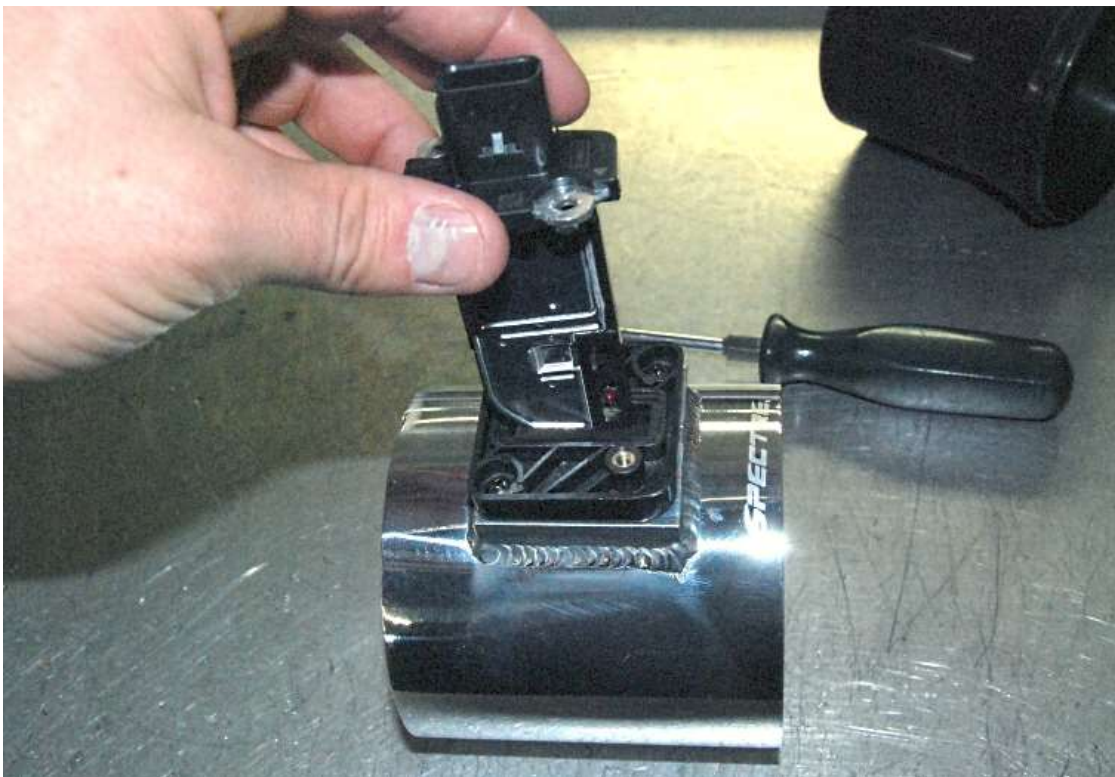

Install the sensor on the mount using the short screws so the flat side of the sensor will face the “Spectre” writing.



Run a bead of Sensor safe RTV silicone around the flange of the large plastic reducer.



Slide the Mass Air Meter tube flat sensor side first (Spectre writing) down onto the plastic reducer.

Wipe any excess RTV off the tube.



Turn the mass air meter over so the Reducer is on the top and let the RTV dry overnight.

Intake tube

SPECTRE MAF SENSOR



Slide the Mass Air Meter tube flat sensor side first (Spectre writing) into the air filter.

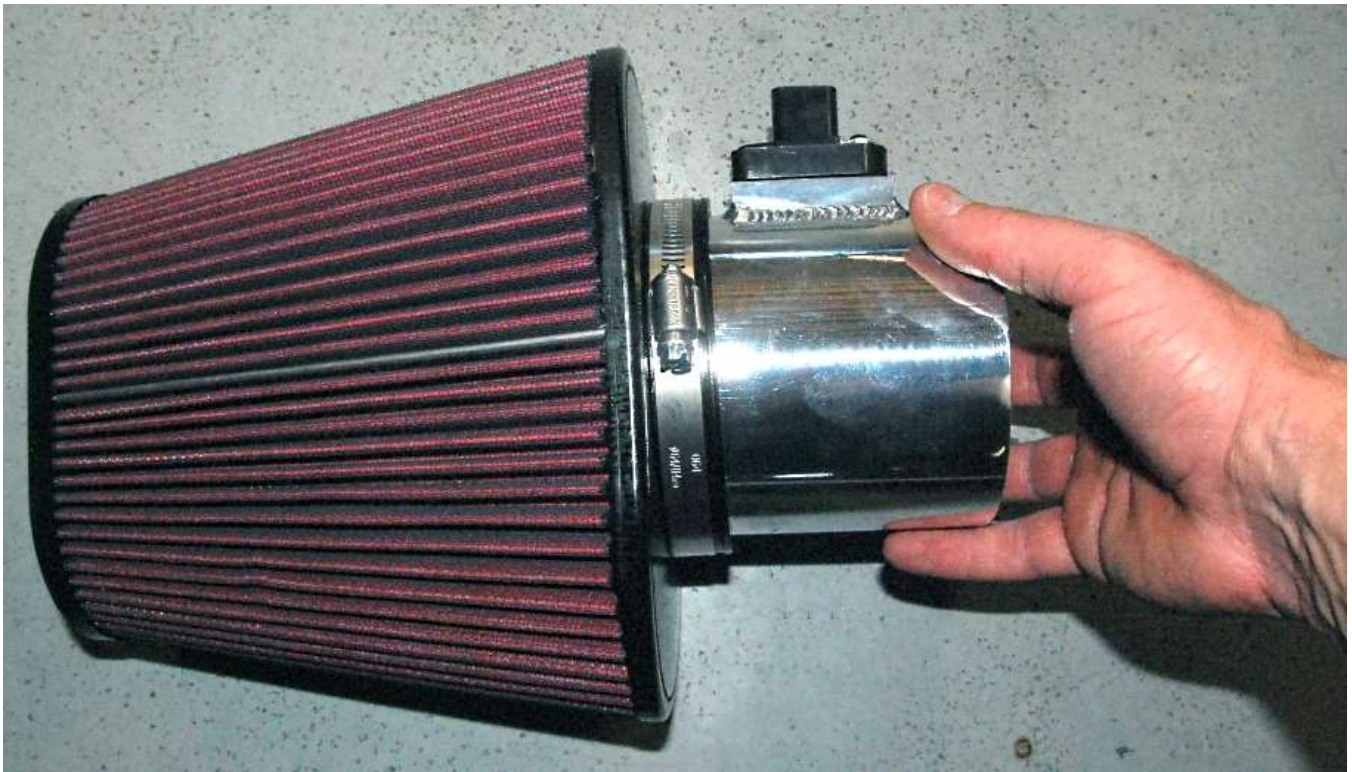

Adjust the Mass air meter so that the mass air plug is on the far side as the Ford Racing instructions recommend.



Tighten the hose clamp.

Connect the elbow tube to the mass air meter using the silicone connector; only tighten one of the hose clamps right now.

Attach the silicone reducer to the tube elbow.

Push the intake tube onto the throttle body and position the air filter under the hood hinge. Tighten the hose clamps.



TREADSTONE MAF SENSOR



Push the FFR filter onto the Mass Air meter making sure that the meter is facing the correct direction.

Slide hose clamps onto the 90° Silicone hose.



Test fit the 90° Silicone hose on the mass air meter and the throttle body, if necessary cut the legs of the hose for radiator and frame clearance.

Adjust the Mass air meter so that the mass air plug is on the far side as the Ford Racing instructions recommend.

Tighten the hose clamps



Push the mass air plug onto the mass air meter.

Accelerator Pedal

✂ Hack saw, $\frac{5}{32}$ " , $\frac{3}{16}$ " Hex keys, $\frac{7}{16}$ " wrench, Marker, Grinder or drill bit, clamp, $\frac{3}{16}$ " , $\frac{1}{4}$ " drill bits, drill





Use a hack saw to cut the right mount off the accelerator. Cut right against the flat section of the pedal so it also cuts the top Webbing off.

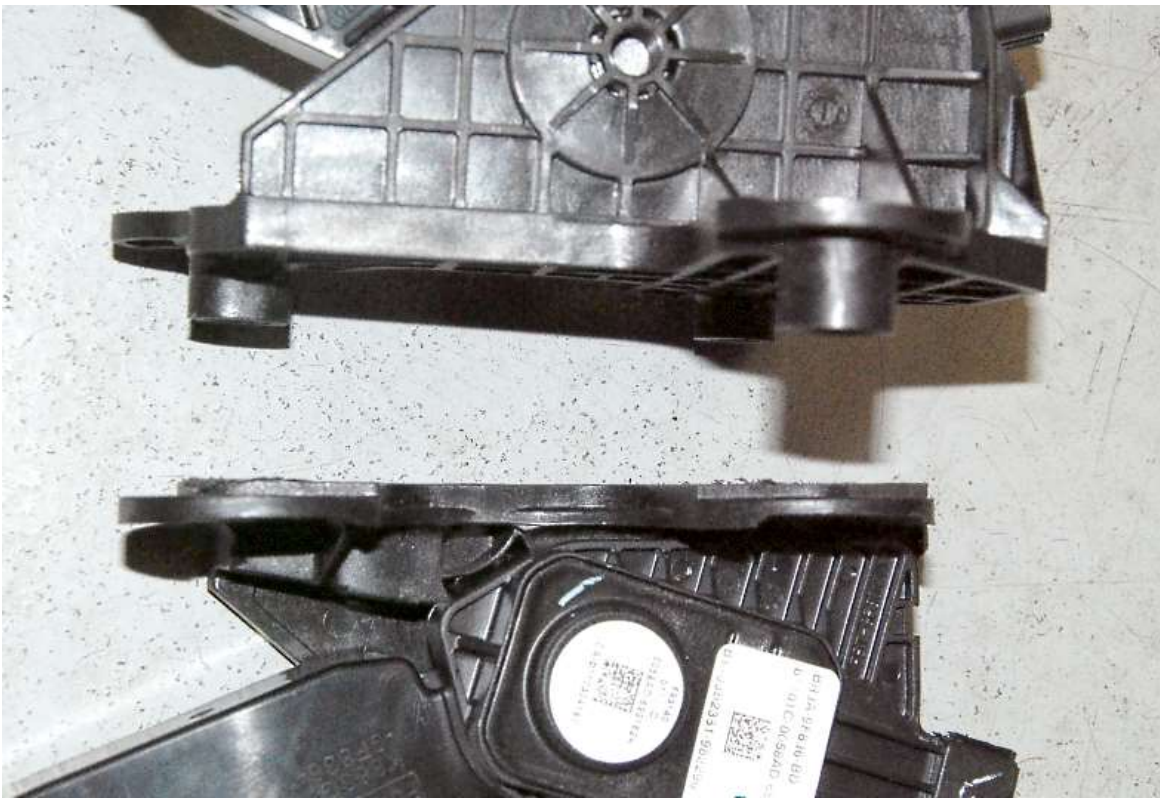

On the underside, cut the bottom mounts off with a hack saw so that the bottom is flat.



Cut the accelerator pedal.

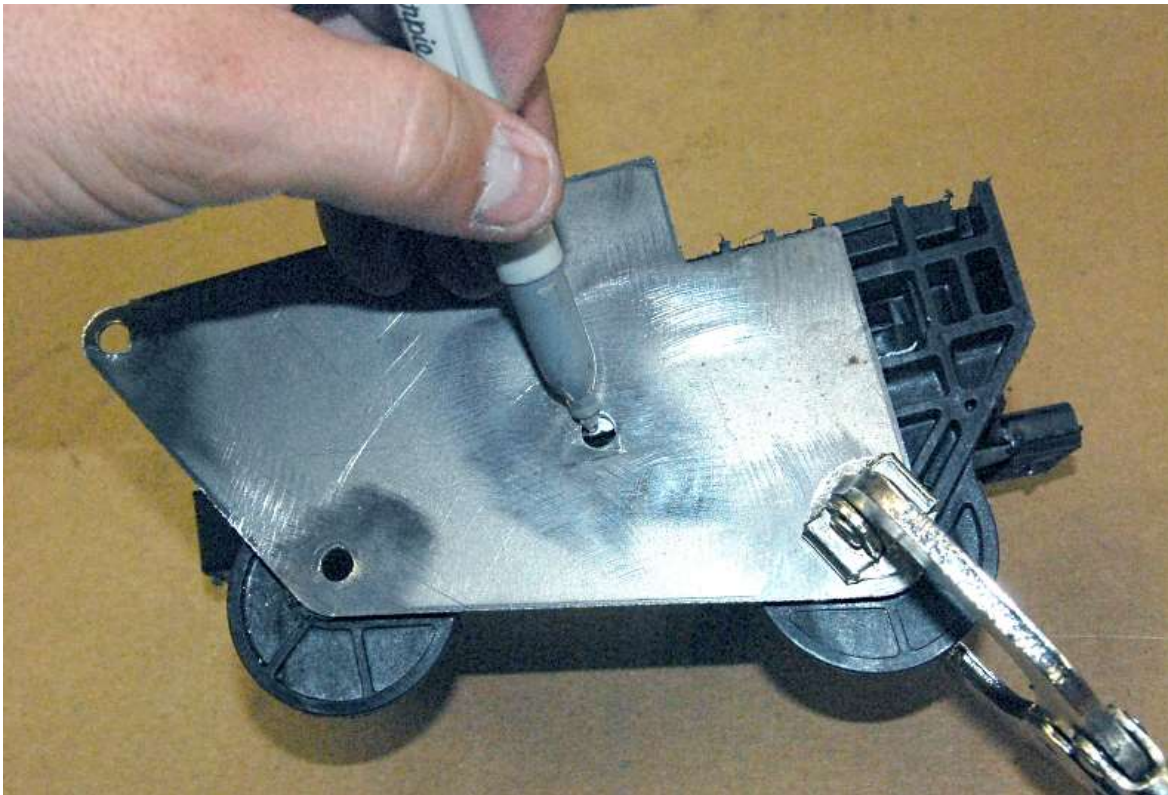

Align the mount holes of the pedal on the pedal mount and mark the pedal through the upper frame mount hole.

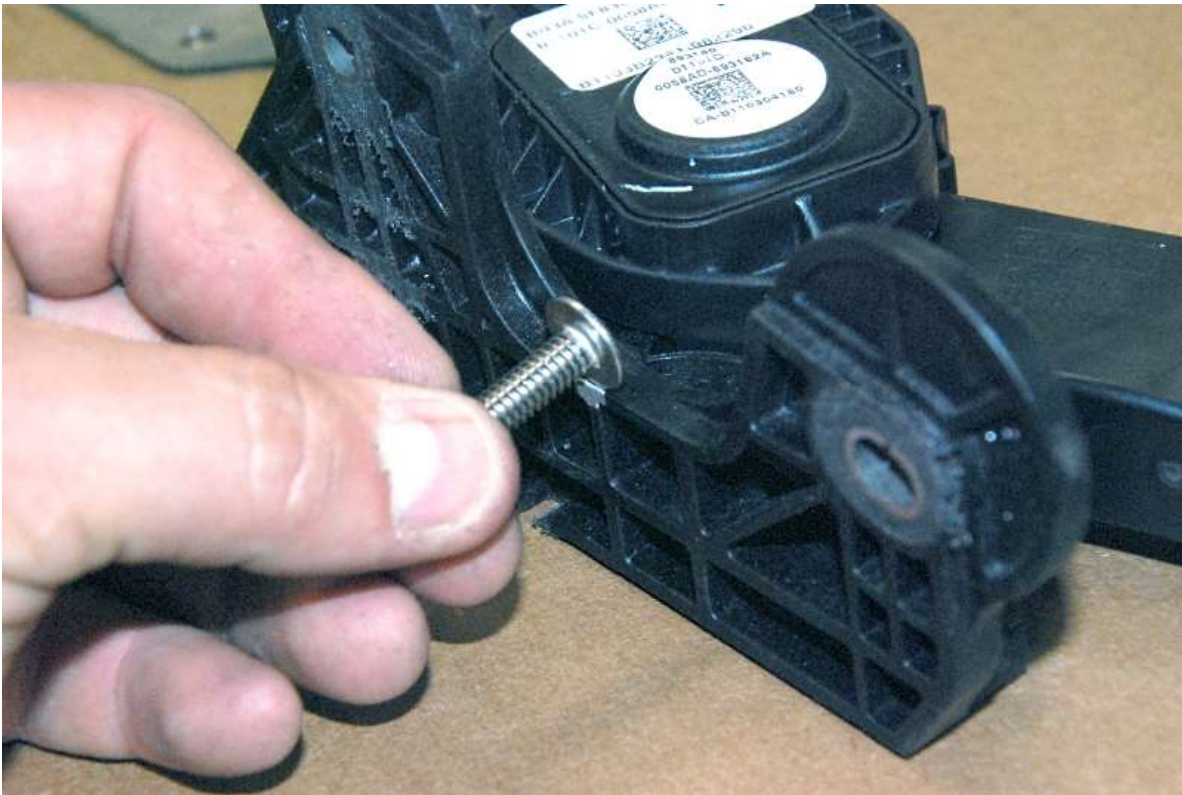

Hold up the mount screw to the pedal at the point marked.



Mark the pedal where the screw starts, stops and the height of the screw.

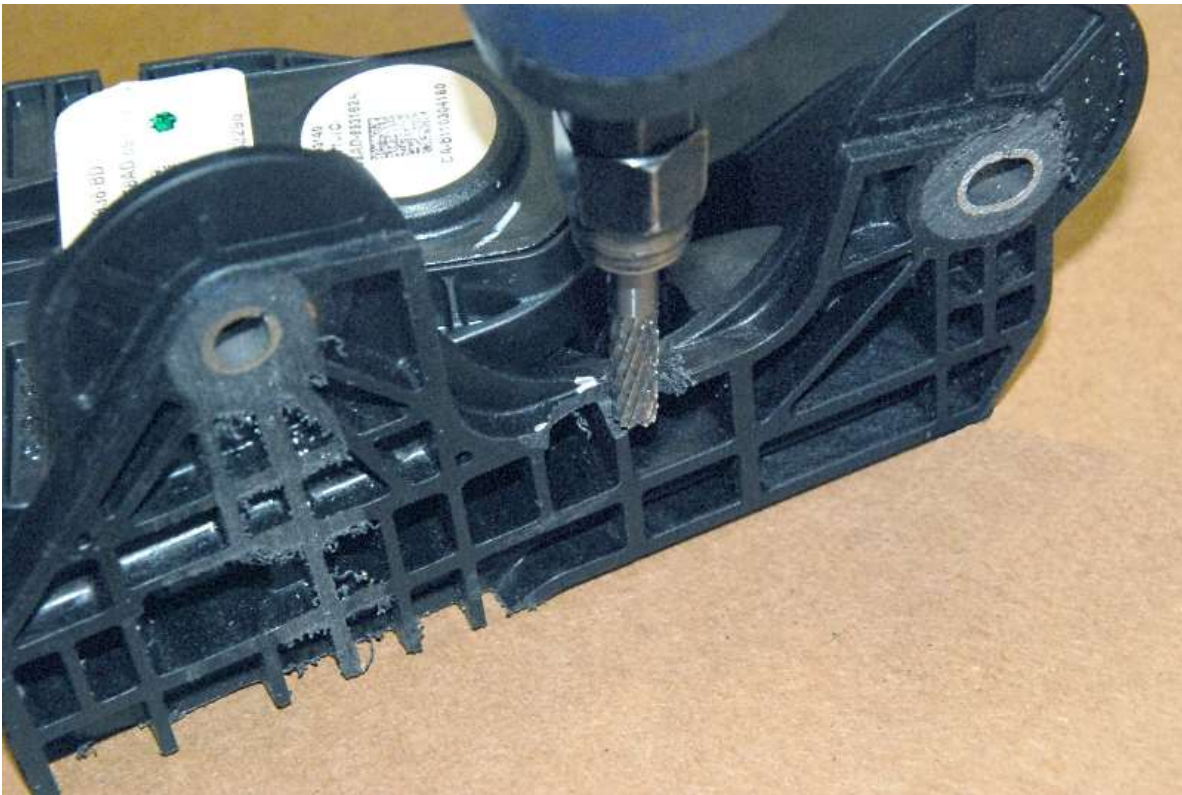

Use a grinder, hack saw or drill bit to remove material on the pedal for screw clearance.



Check the fitment of the mount screw by putting the pedal on the pedal mount with the screws.

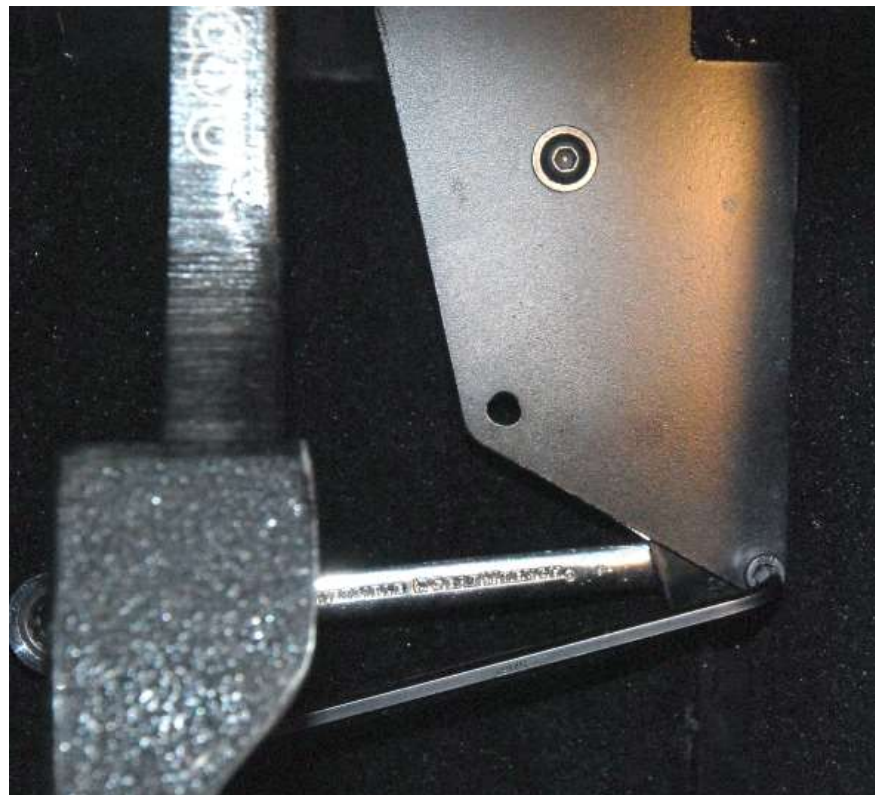
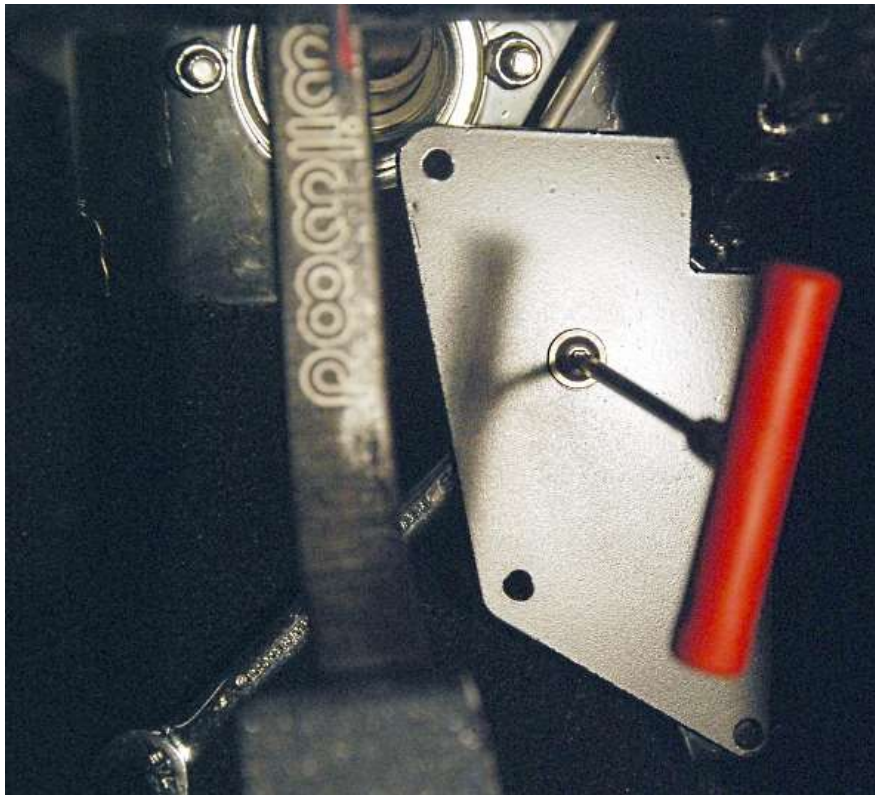

Attach the Accelerator pedal mount to the frame accelerator pedal mount using the 1/4" screws provided and the ones from the standard kit.

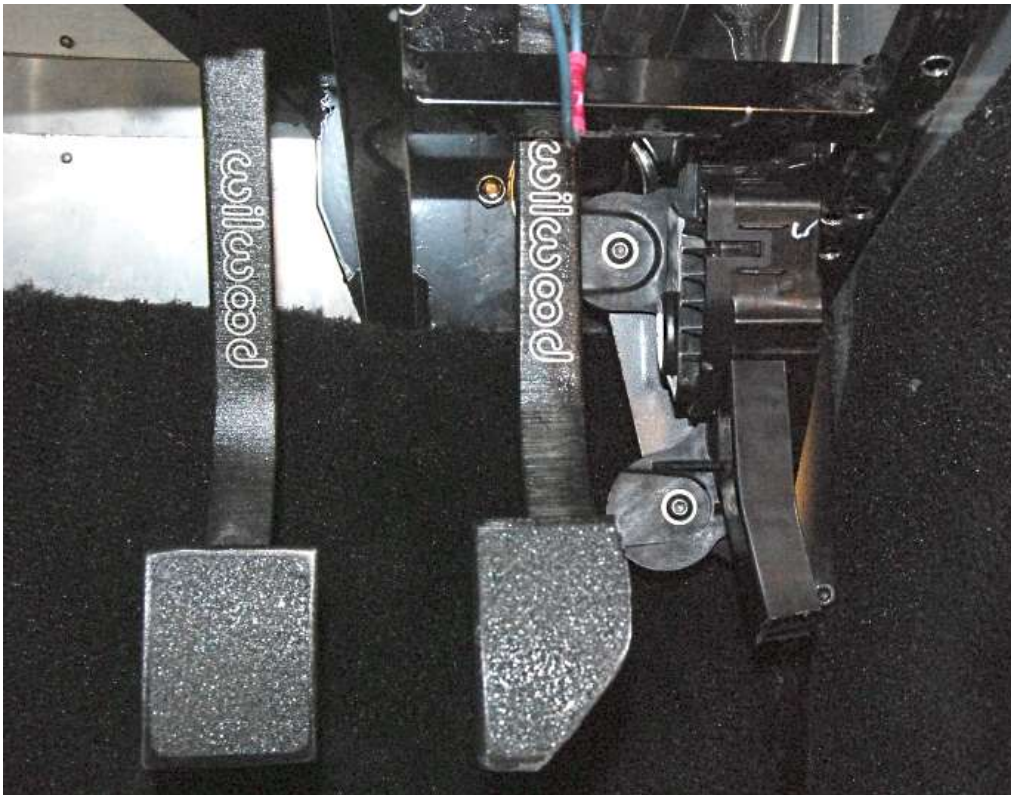

Attach the Coyote accelerator pedal to the new pedal mount.



Cut the FFR accelerator pedal at the bottom of the existing mount hole using a hack saw.

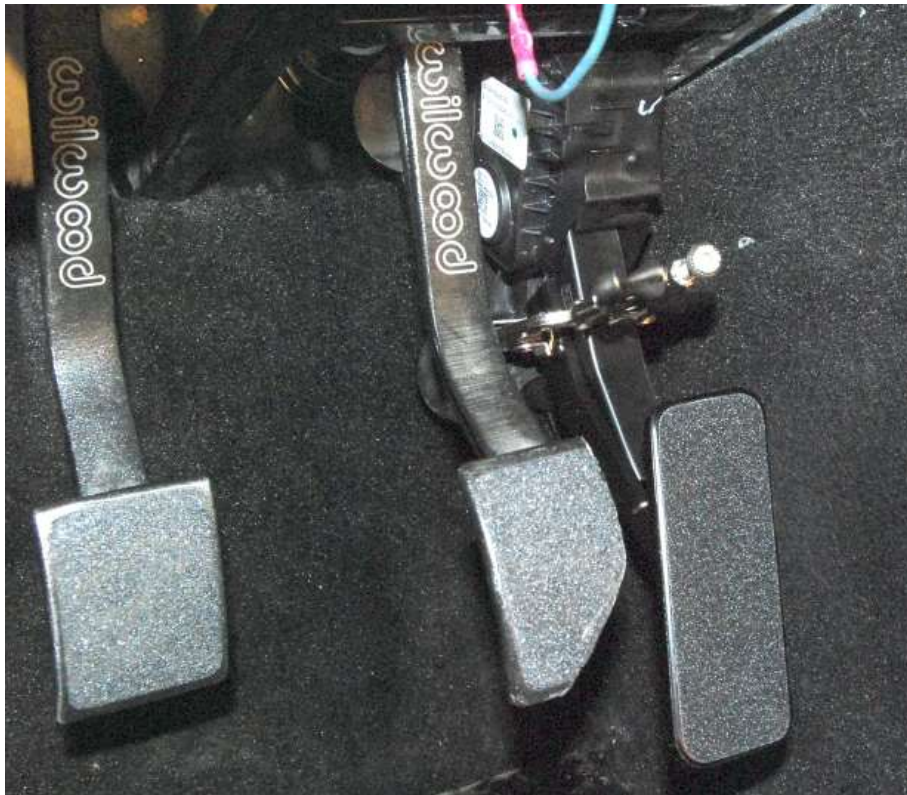

Clamp the FFR pedal to the Coyote pedal with a small clamp so that the accelerator pad is $2\frac{1}{8}$ " back from the brake pedal.



This is a starting point



Sit in the car and push the brake pedal down as if you were stopping the car. You should be able to push the pedal down without hitting the gas pedal but be able to rock your foot (heel/toe) onto the gas pedal.

Once the correct height is set, mark the side of the coyote pedal using a paint marker.



Remove the pedal from the car and check the alignment of the two pedals with the line you just drew.



On the backside of the pedal insert one of the 1/4" locknuts into one of the recesses so that the bolts will be as far apart as possible and still go through both the FFR pedal and the Coyote pedal.



Using the locknut nylon as a guide, drill a $\frac{3}{16}$ " hole through the plastic pedal.

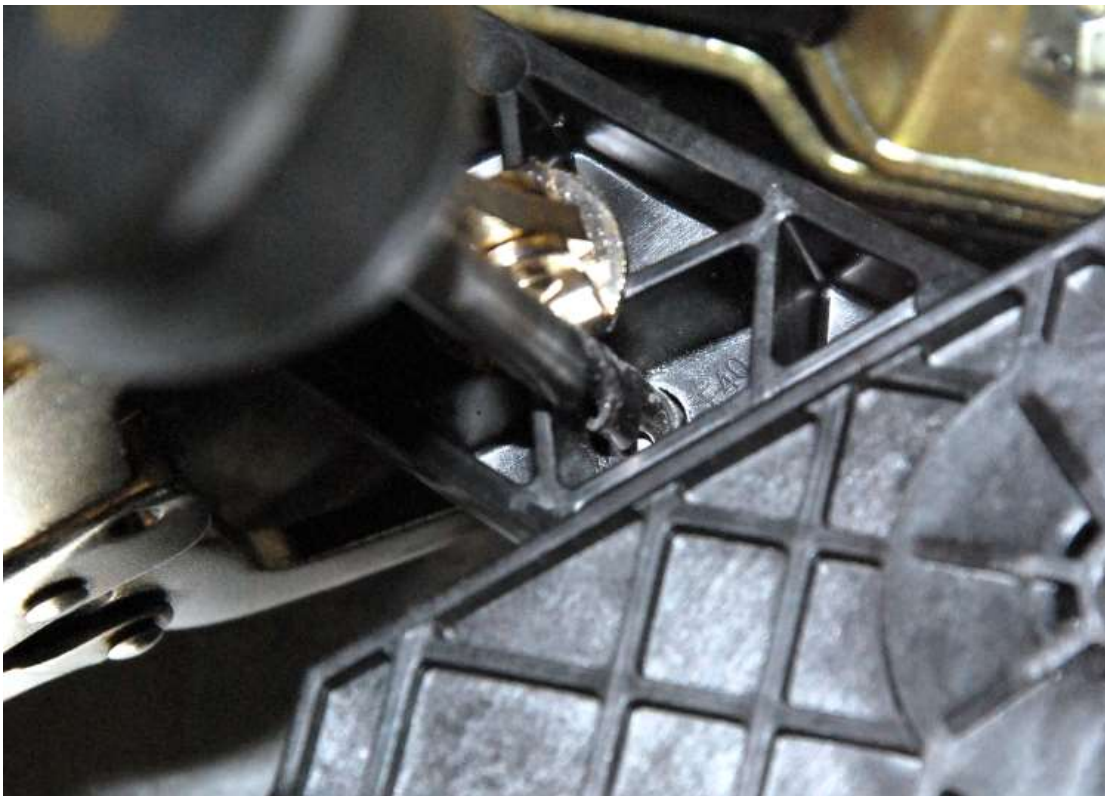

Remove the locknut and enlarge the hole using a $\frac{1}{4}$ " drill bit.



Check the alignment of the metal pedal on the plastic pedal then drill through the metal pedal using the plastic hole as a guide.

Attach the metal pedal to the plastic pedal using one of the ¼"-20 x ¾" screws and locknuts included with the kit.



If your pedal location requires bolting below the bend in the plastic pedal, mark the location of the bend.



Use a pair of pliers and a vise to slightly bend the metal pedal to match the plastic.

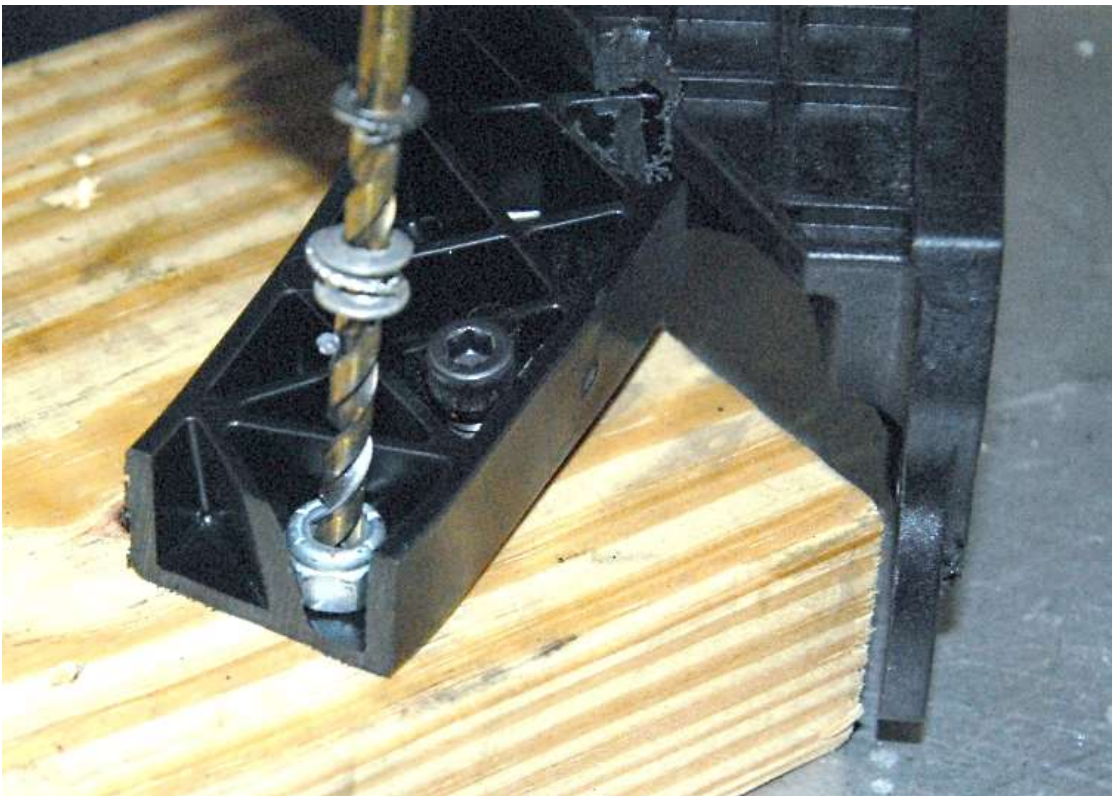

Use another lock nut and drill bit to locate the lower hole location and drill a pilot hole.

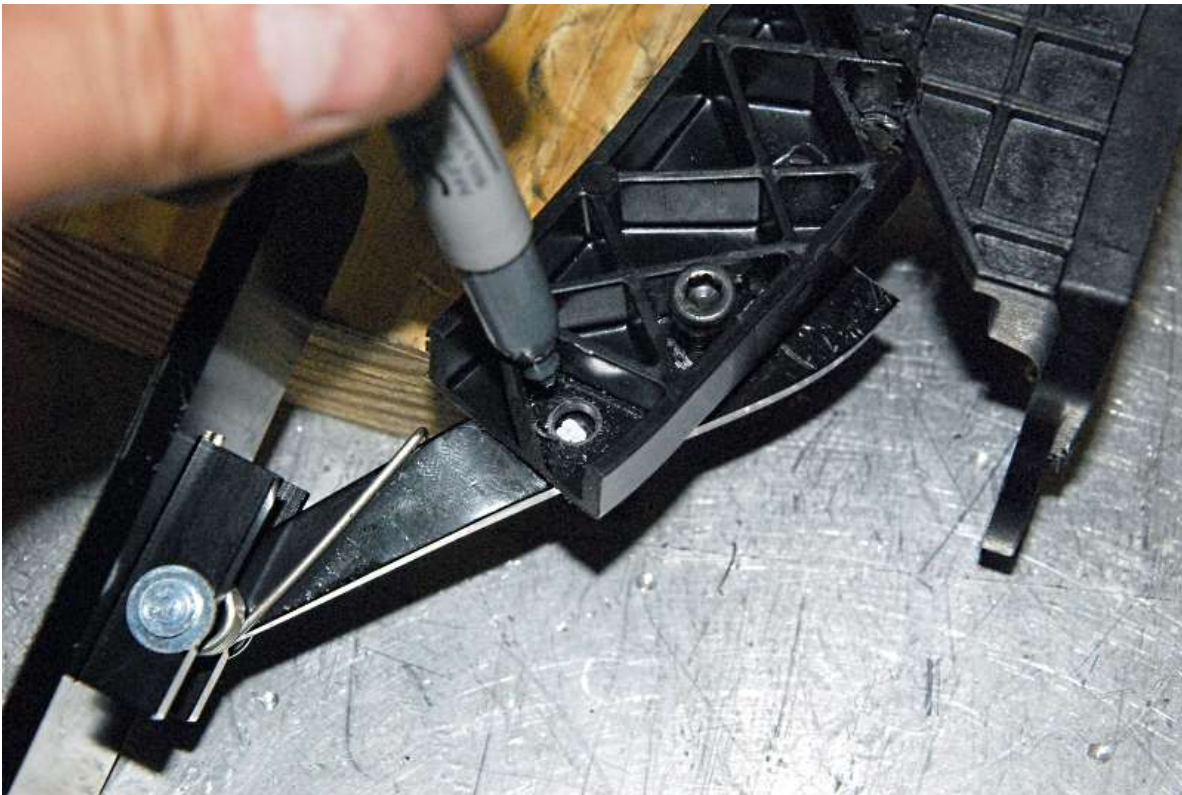

Mark and drill the location on the metal pedal.



Use one of the flanged $\frac{1}{4}$ "-20 x $\frac{3}{4}$ " screws in the lower hole.



Mount the pedal to the new pedal mount in the footbox.

Exhaust

- ✂ 15mm, 17mm sockets, 15mm wrench
- 🚗 Coyote headers, straight pipes

👉 **The threads in the heads for the headers changed a couple times during production Be careful when installing the headers bolts so the threads are not ruined. After removing the headers studs, compare the thread to the new header bolts.**

Production header bolt change dates:
From 3-22-10 to 9-8-10 M10 x 1.50 Coarse
From 9-8-10 to 1-18-11 M10 x 1.25 Fine
From 1-18-11 M10 x 1.50 Coarse

FFR supplies the course bolts only. If the fine thread bolts are needed, the specifications you require when you purchase the bolts are: M10 x 1.25mm x 25mm long grade 8.8 hex head bolt

- 👉 Insert and tighten all of the bolts by hand before tightening any with a wrench.

Attach the headers to the engine.
Attach the connector pipes to the headers and kit exhaust system.

Starting the engine

- 🚗 Oil, Coolant

If not already done, fill the engine with 8 quarts of the correct oil.



If not already done, fill the engine with coolant through an inline filler or radiator cap. To help remove air from the system, remove the top cap until coolant starts going up the tube then recap and hose clamp.

Fill the coolant overflow container.

Set the Fuel pressure regulator to the correct pressure as described in the Ford Racing engine control instructions.

Start the engine and allow the engine to get up to 195°F- 200°F then allow to cool completely, it will suck coolant from the overflow.

👉 Cooling fan is switched on at 195°F, turns off at 190°F. This is based on inferred engine coolant temperature. Engine coolant temperature is inferred from the cylinder head temperature. Inferred coolant temperature may not be the same as actual coolant temperature.

Once cool, check the radiator/inline filler neck and coolant overflow container. Top up with coolant if necessary.