



Controlled Documentation

Part Number: 11263

Revision: F

Effective Date: 06/13/11

By: J. INGERSLEV

Document Type (indicate):

◦ Bill of Material

◦ Drawing (may be attached)

◦ Specification

• **Assembly Instructions**

◦ Operating Procedure

◦ Other

Seat Track Installation Instructions

Note:

- These instructions do not apply to the GTM.
- For Hot Rod, go to page 4

I. Tools Required:

Jack

Jack stands

1/2" socket

3/8" socket

Ratchet

3/16", 5/16" drill bit

Ruler

Marker

3/16" Hex Key

II. Roadster/Coupe Installation Instructions

1. Remove the studs from the tracks if so equipped. They are not used in our application.
2. Slide the seat tracks forward and turn the seat track upside down.
3. Mark 1/8" back from the side of the square hole.

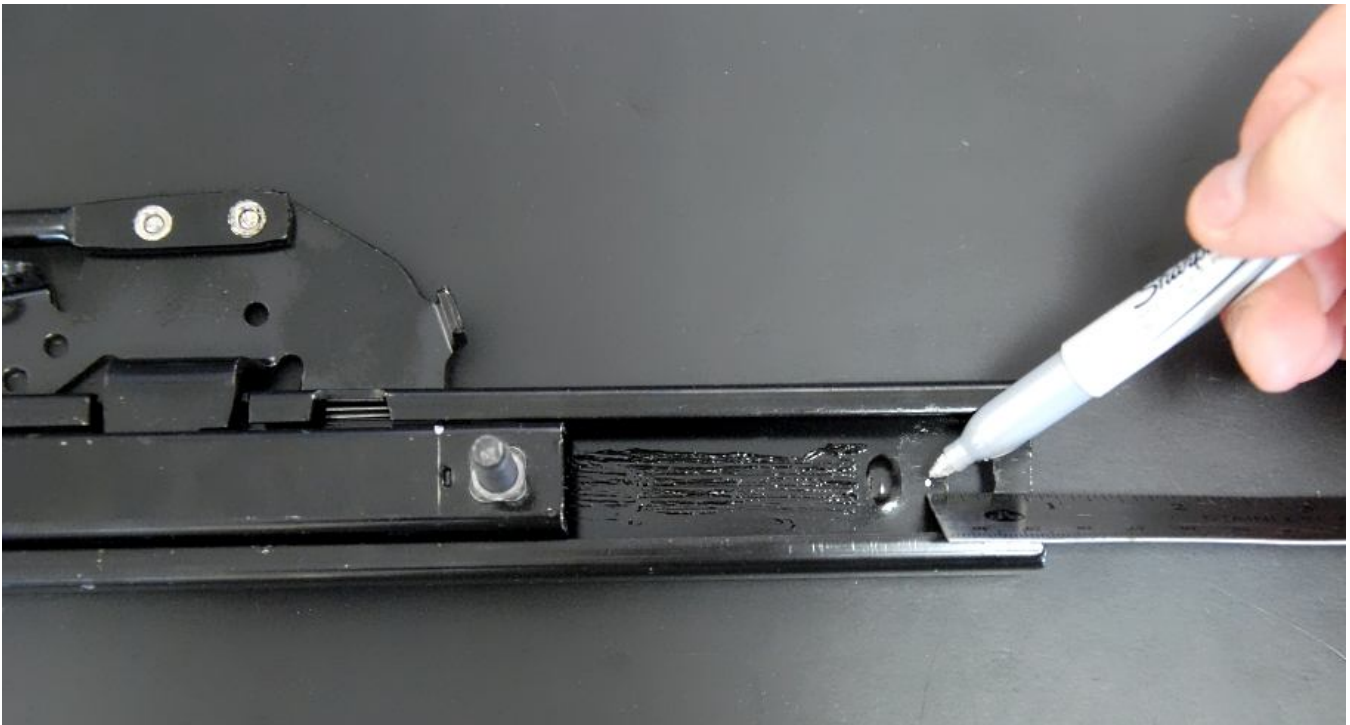

4. Use a $\frac{3}{16}$ " drill bit at the point marked on the tracks then open this up with a $\frac{5}{16}$ " drill bit.

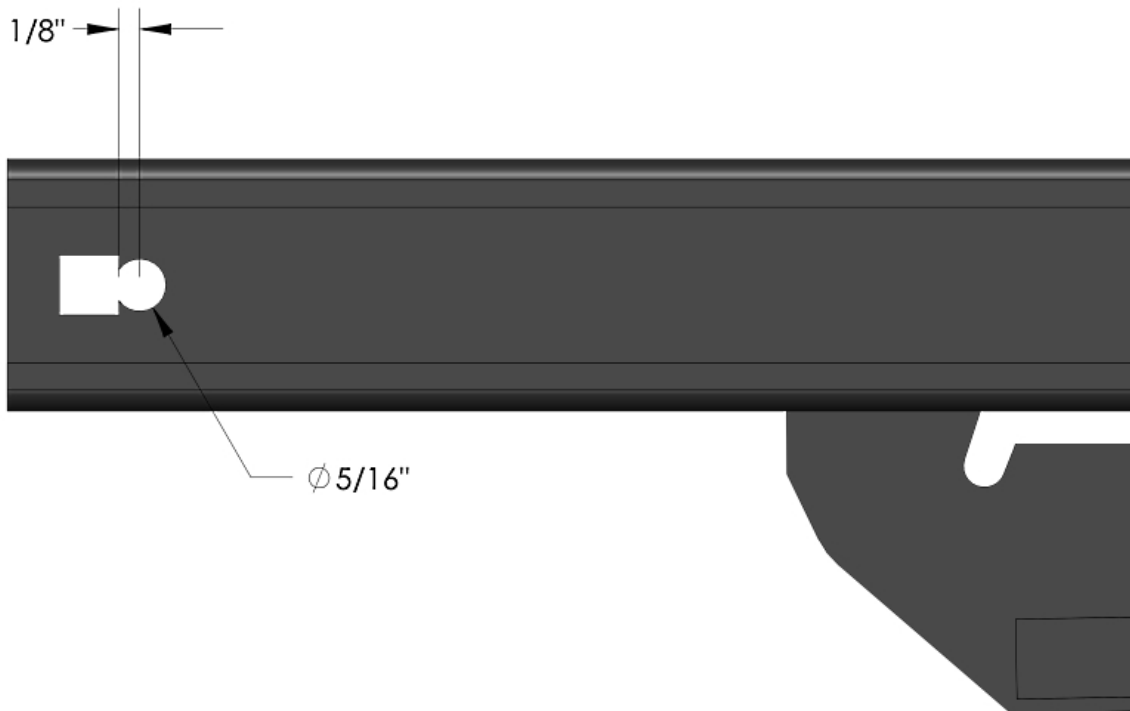

5. Mark the front bolt location in the rectangular hole on top of the seat tracks (wide side) $10\frac{13}{16}$ " from the center of the rear square hole.
6. Jack the Driver side of the car up and place on jack stands.

REV.	DESCRIPTION	DATE	APPROVED
A	INITIAL RELEASE	7/2/02	
B	FASTENER CHANGE	5/13/11	

ITEM NO.	PART NUMBER	DESCRIPTION	QTY.
1	TOP	TOP	1
2	TOP	TOP WITH HANDLE	1
3	HLSCREW 0.2500x1.5		2
4	S8HCSCREW 0.3125-18x1.5-HX-N		4
5	S8HCSCREW 0.3125-18x2.5-HX-N		1
6	S8HCSCREW 0.3125-18x1-HX-N		1
7	HNUT 0.3125-18-D-N		4
8	NLN-3125C	NYLON INSERT LOCKNUT, 5/16-18 UNC	6
9	Regular FW 0.3125		2

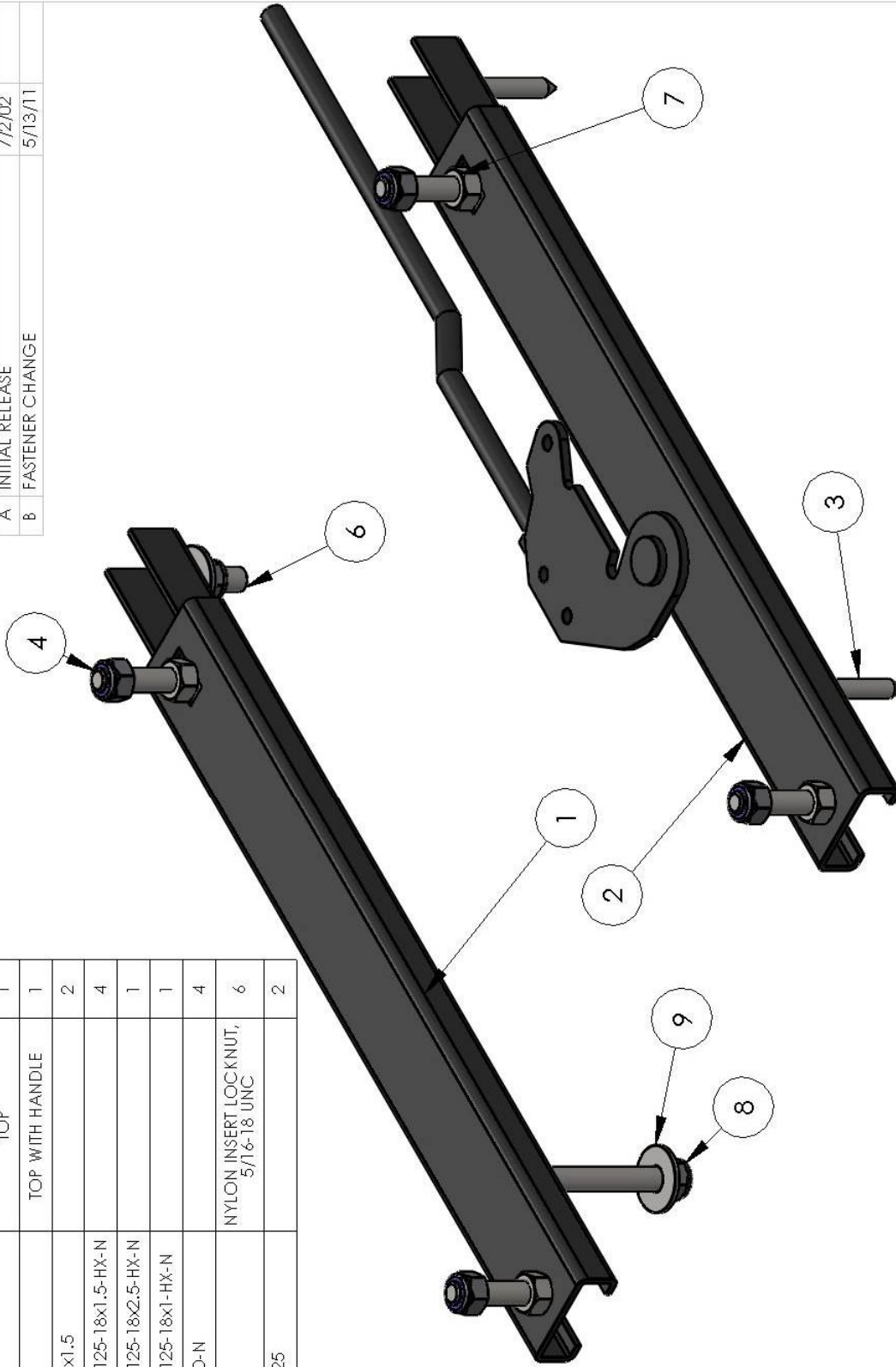

UNLESS OTHERWISE SPECIFIED:		NAME	DATE
ROADSTER	DIMENSIONS ARE IN INCHES	JL	5/13/11
COUPE	TOLERANCES: TWO PLACE DECIMAL ±0.01 THREE PLACE DECIMAL ±0.005 FOUR PLACE DECIMAL ±0.001		
HOT ROD	MATERIAL		
	FINISH		
USED ON	BLACK		
APPLICATION		PRINTED	5/13/2011



Factory Five Racing, Inc.

SEAT TRACK ASSEMBLY

SIZE DWG. NO. REV
A **10809** **B**

SCALE: 1:2 WEIGHT: SHEET 1 OF 1

PROPRIETARY AND CONFIDENTIAL
 THE INFORMATION CONTAINED IN THIS DRAWING IS THE SOLE PROPERTY OF FACTORY FIVE RACING, INC. ANY REPRODUCTION IN PART OR AS A WHOLE WITHOUT THE WRITTEN PERMISSION OF FACTORY FIVE RACING, INC. IS PROHIBITED.

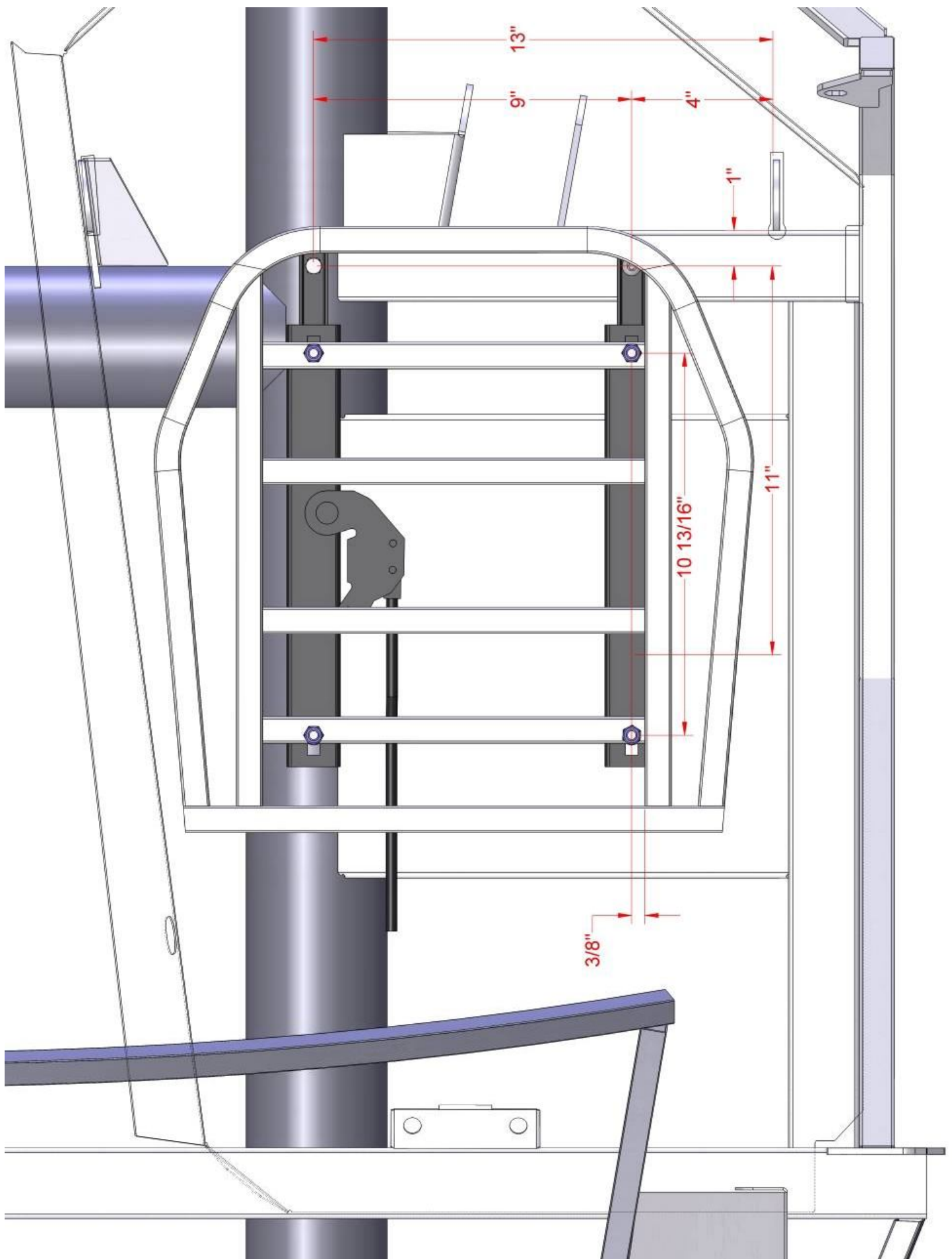

7. Draw a line on the drivers floor 1" forward from the outer seat harness mount and 13" towards the inside of the car. This is the middle of the 4" round tube which touches the aluminum floor panel and the inner rear seat track mount.
8. From the outer seat belt mount. Measure 4" in along the line just made. This is the location of the reare outer seat track mount.
9. The front holes for both tracks are $10^{13/16}$ " forward of the rear holes.
10. There are two ways to mount the inner seat track. Using the self tapping screws provided or bolts (not provided). If using bolts, be sure to use the right drill bit in order to tap the holes for the 4" round tube properly.
11. If using the supplied screws, drill $3/16$ " holes at the inner track locations marked.
12. Use a $5/16$ " bit for the outer track hole locations.
13. On the seat tracks, insert the $5/16$ " x1.50" screws through the holes in the seat tracks so that they point up. Use the $5/16$ " nuts, without the nylon lock, on the top side of the track and tighten them. For the front rectangular hole, locate the bolt so that it is $10^{13/16}$ " forward of the rear bolt.
14. Mount the inside seat track (has the locking handle) using the 1.50" screws and a $3/8$ " socket.
15. Mount the outer seat track (non-locking) using the $5/16$ " x1" screw provided, and one of the bolts included with the seats in the rear as shown in the picture at the beginning.
16. Flip the seat bottom forward and mark the seat frame for the track mounting holes using the diagram on the previous page:
 - Front holes** – as forward as possible on the second tube from the front, $3/8$ " in from the front to back tube and 9" over from that.
 - Rear holes** – $10^{13/16}$ " back from the front hole locations.
17. Using a $5/16$ " drill bit, drill through seat frame.
18. Place the seat on the seat tracks and fasten using the four $5/16$ " lock nuts.
19. Flip the seat back down.
20. Remove the jack stands using a floor jack.

III. Hot Rod Instructions

1. Remove the rear studs from the tracks if so equipped. They are not used in our application.
2. Mark the front bolt location in the rectangular hole ontop of the seat tracks (wide side) $10^{13/16}$ " from the center of the rear square hole.
3. Drill new $5/16$ " rear mount holes in the floor mount side (narrow side) 2.50" forward of the square holes that had the studs in.
4. Jack the Driver side of the car up and place on jack stands.

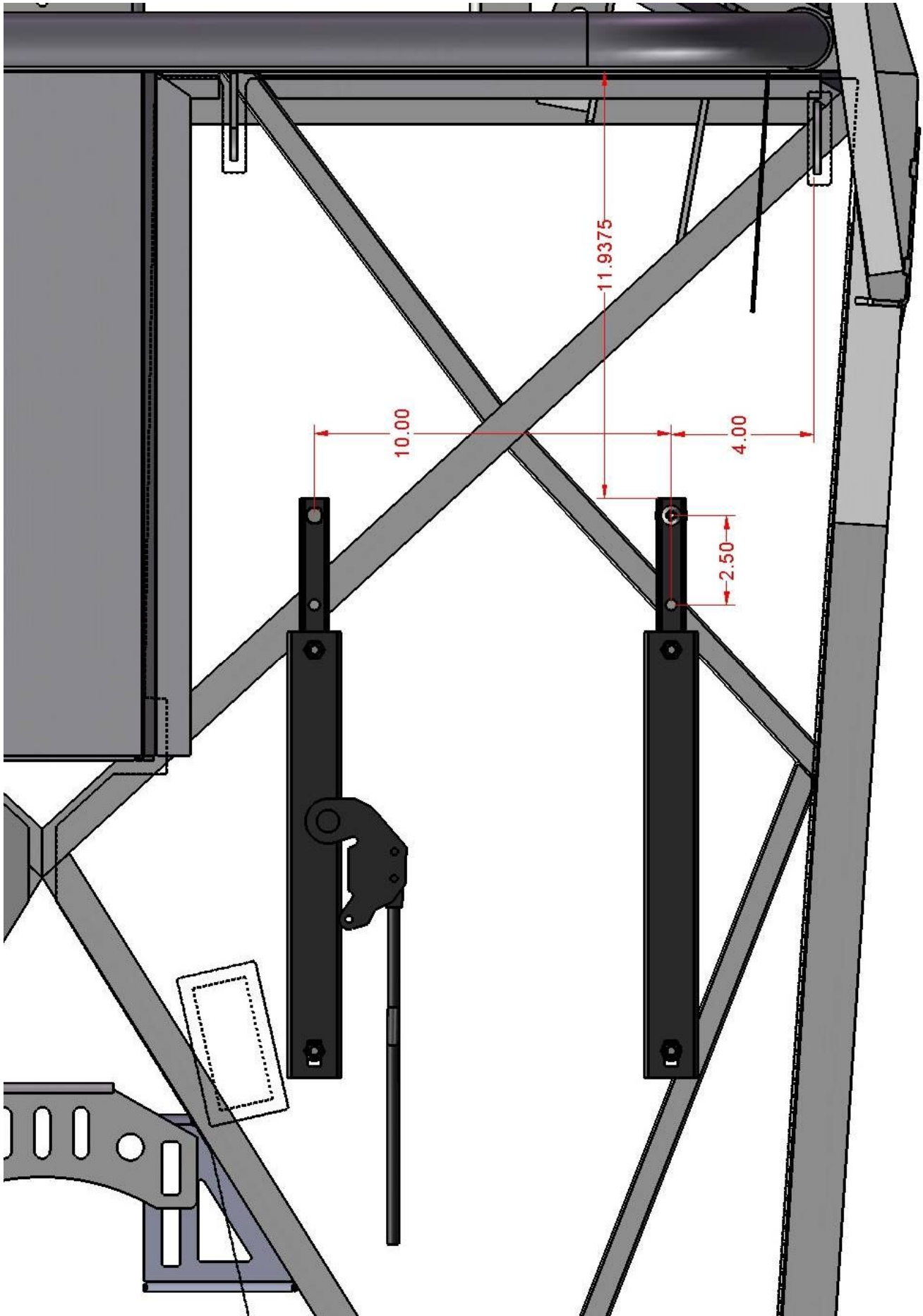

21. Mark on the drivers floor 11.9375" forward from the cockpit rear wall at 4" from the inside of the outer seat harness mount and 14" towards the inside of the car. These should be right on top of the frame steel. These are your rear track mounts.
22. The front holes for both tracks are 9.50" forward of the rear holes.
23. Use a $\frac{5}{16}$ " bit to drill the track hole locations marked.
24. On the seat tracks, insert the $\frac{5}{16}$ " x 1.50" screws through the holes in the seat tracks so that they point up. Use the $\frac{5}{16}$ " nuts, without the nylon lock, on the top side of the track and tighten them. For the front rectangular hole, locate the bolt so that it is $10\frac{13}{16}$ " forward of the rear bolt.
25. Use the supplied bolts or the kit supplied seat mount bolts for the rear track to frame bolts.
26. Use the kit supplied washers and lock nuts for the two front track studs
27. Flip the seat bottom forward and mark the seat frame for the track mounting holes using the diagram on the previous page:
 - Front holes** - Centered on the second tube from the front, $\frac{3}{8}$ " in from the front to back tube and 10" over from that.
 - Rear holes** – $10\frac{13}{16}$ " back from the front hole locations.
28. Using a $\frac{5}{16}$ " drill bit, drill through seat frame.
29. Place the seat on the seat tracks and fasten using the four $\frac{5}{16}$ " lock nuts.
30. Flip the seat back down.
31. Remove the jack stands using a floor jack.