



Factory Five Racing, Inc.

Part Number: 15042

Revision: C

Effective Date: 06/03/13

By: J. Ingerslev

Document Type (indicate):

◦ Bill of Material

◦ Drawing (may be attached)

◦ Specification

• **Assembly Instructions**

◦ Operating Procedure

◦ Other

11.65" Rear Brakes

Installation instructions



- ✎ These instructions apply to any 1986-2004 Ford Mustang 8.8 rear axle with Traction-Lok differential (FFR#s 14319,14970) using 1994-2004 OEM Mustang style disc brakes (FFR#s 14834, and 14903).
- ✎ The installation of this kit can be performed by anyone with an average amount of mechanical experience, but it is very important to follow the instructions and refer to a Mustang Shop Manual or equivalent. If you do not feel comfortable after reading the instructions and the shop manual, have the installation performed by an experienced mechanic.
- ✎ Improper installation of this kit could adversely affect the safety of your vehicle
- ✘ **Torque Wrench, 8mm, 16mm, 1/2" x 1/16" sockets, Ratchet, Needle nose pliers, Small flat head screwdriver, (2) Jack stands**

Supplies

Brake Fluid

Instructions

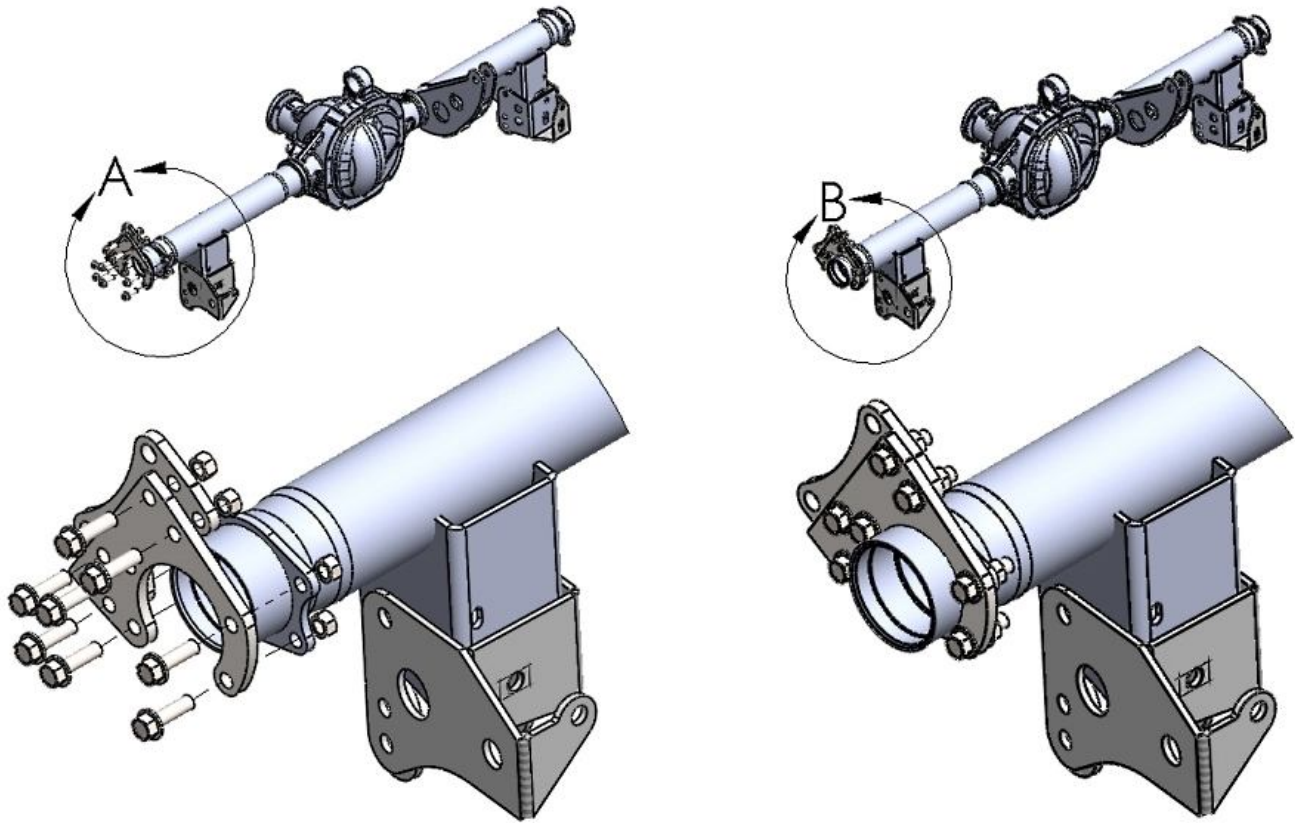

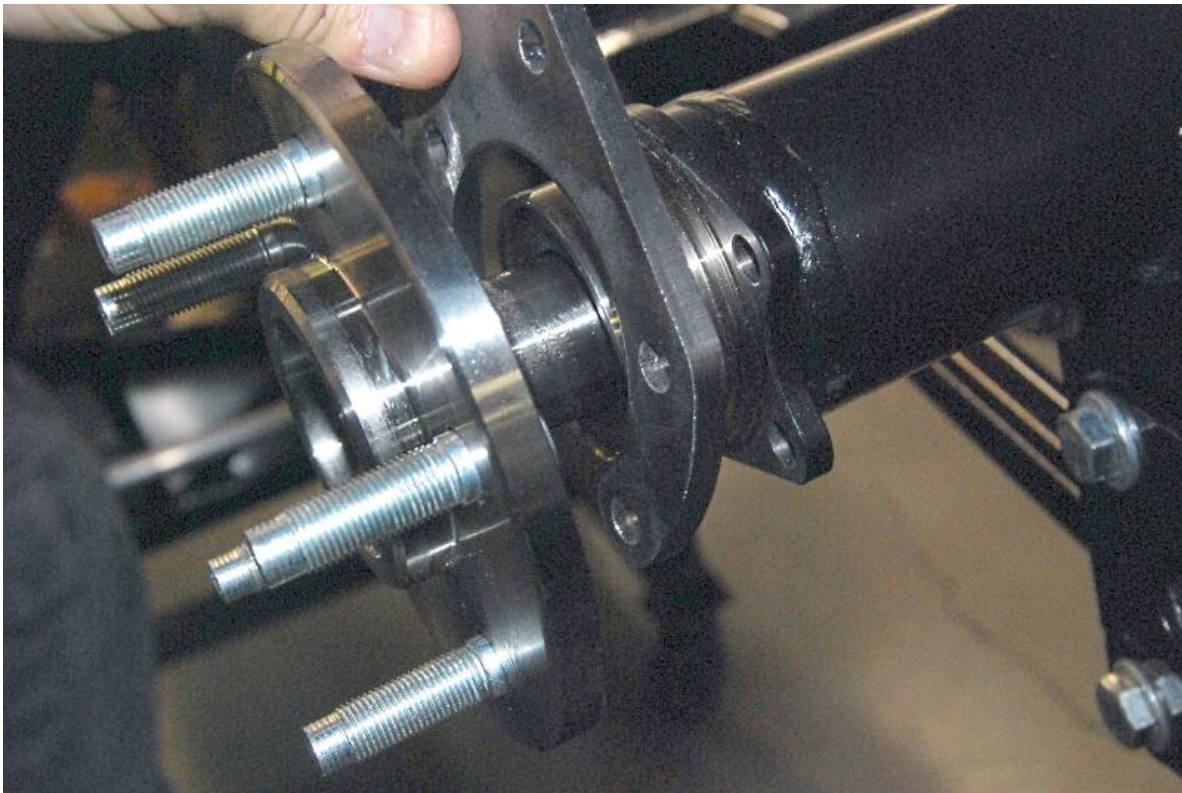

Place the caliper “C” shaped caliper axle mount bracket over the Axle so that the open part of the bracket is facing down.

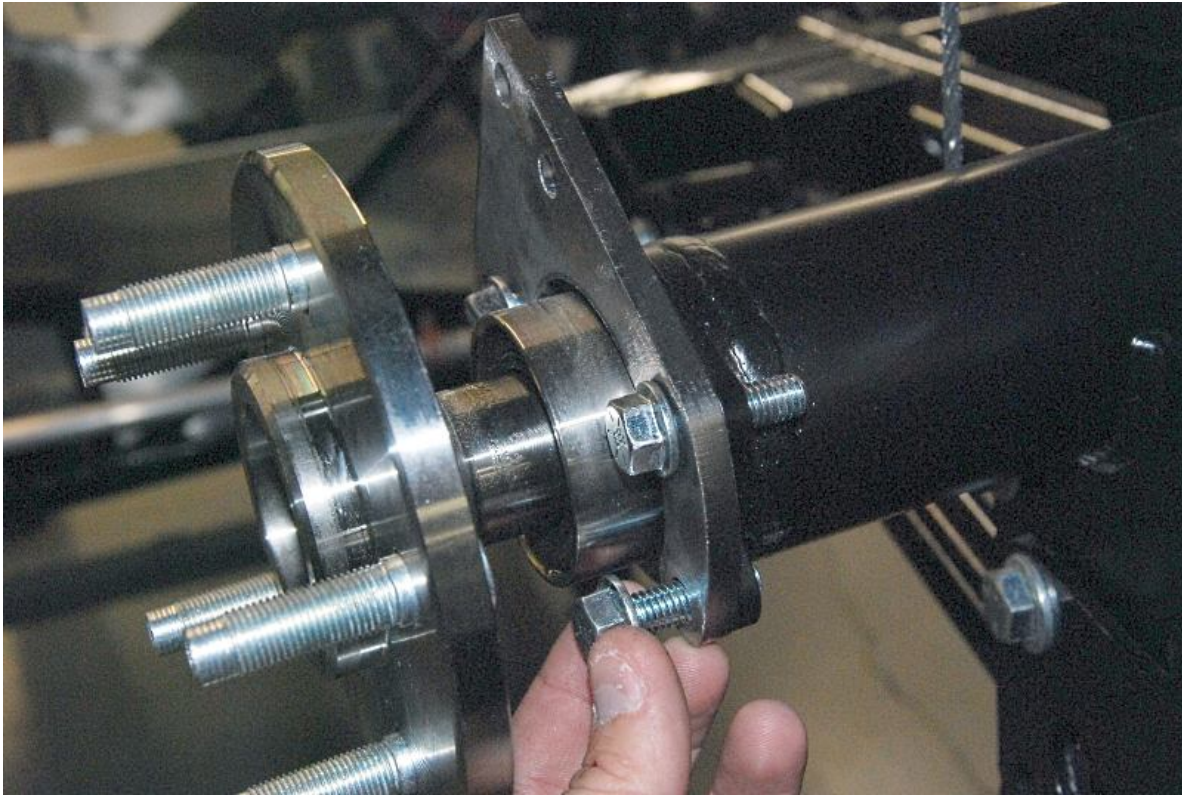

Insert the caliper axle mount bracket bolts from the outside in.

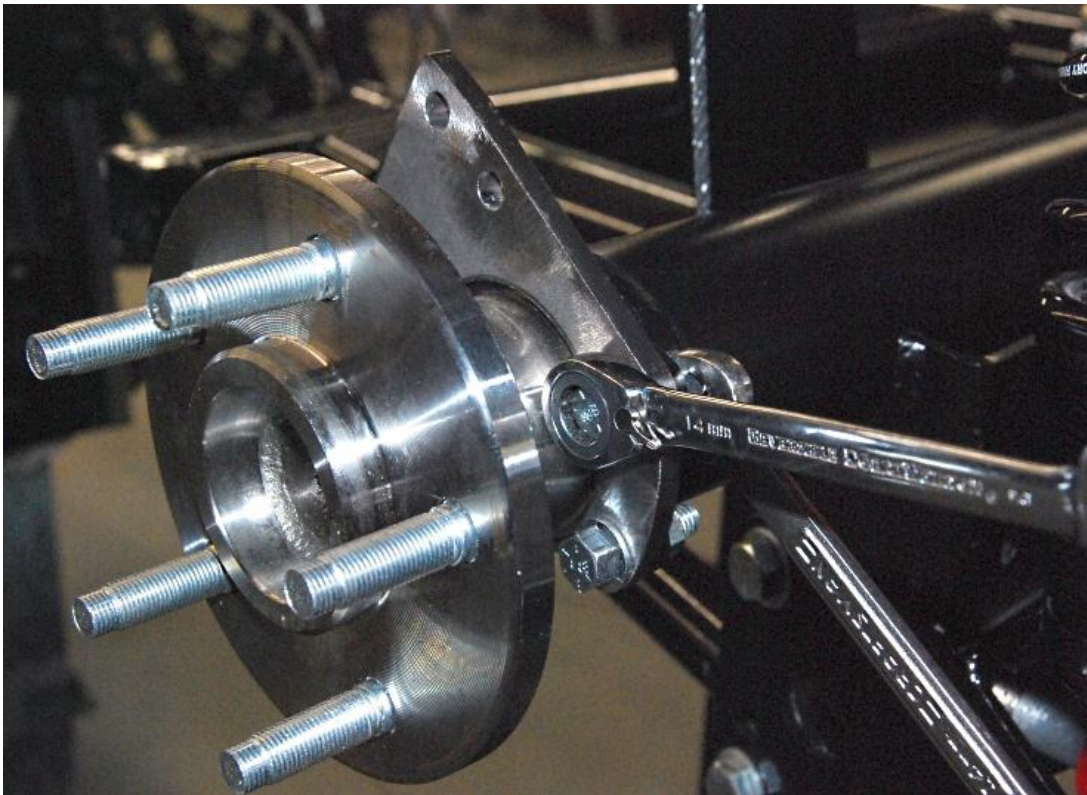

Torque the caliper bracket to 45-50 ft-lbs.

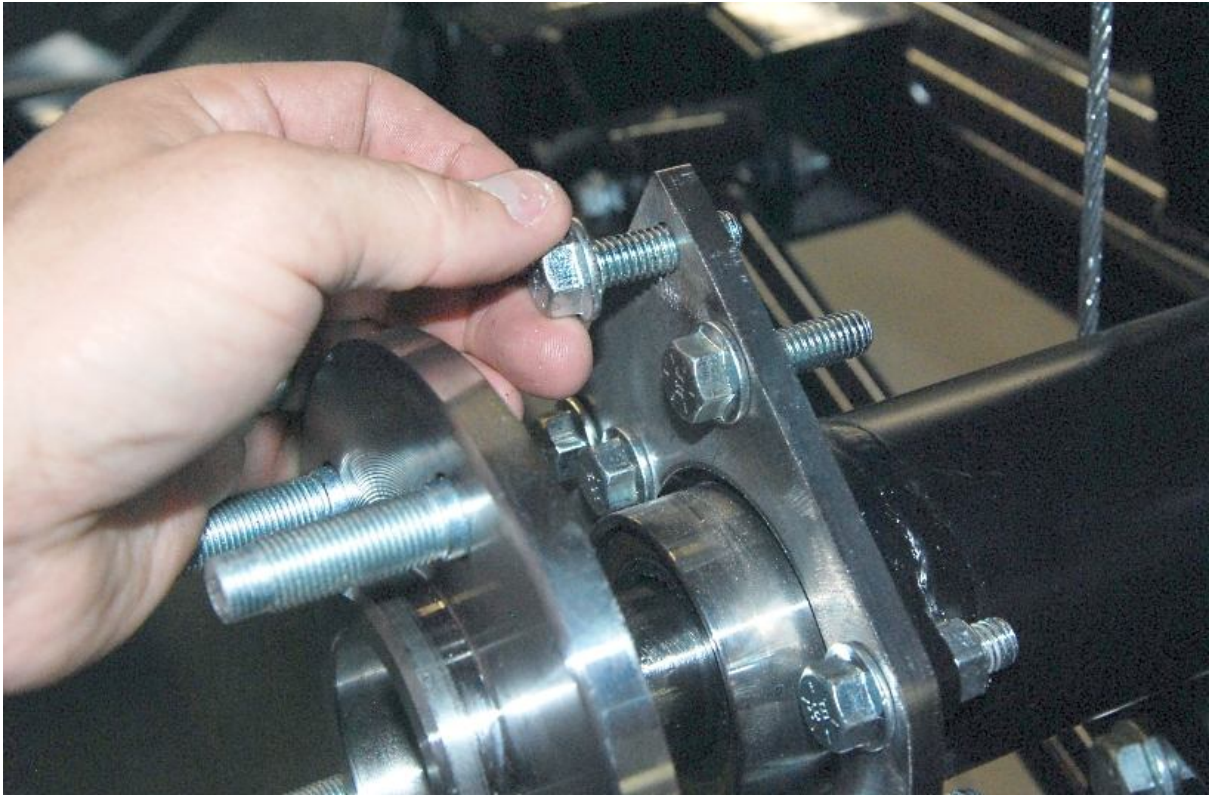

Insert the caliper mount bracket bolts from the outside in through the four remaining bracket holes.

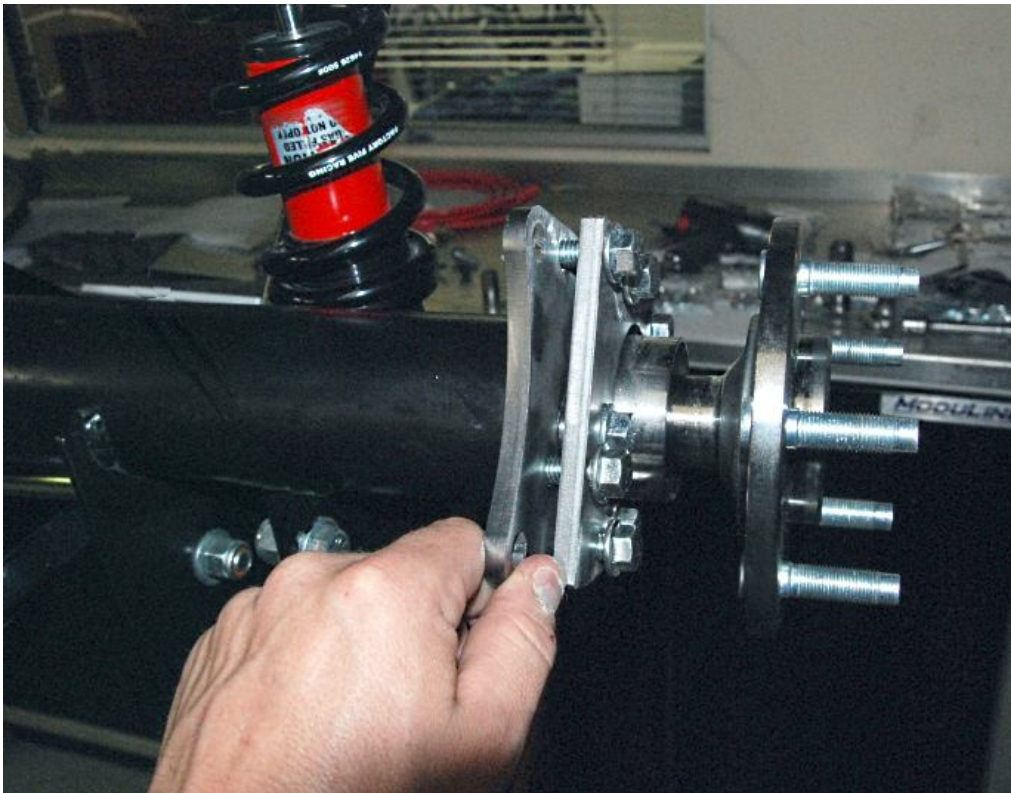

Slide the caliper mount bracket onto the four bolts.

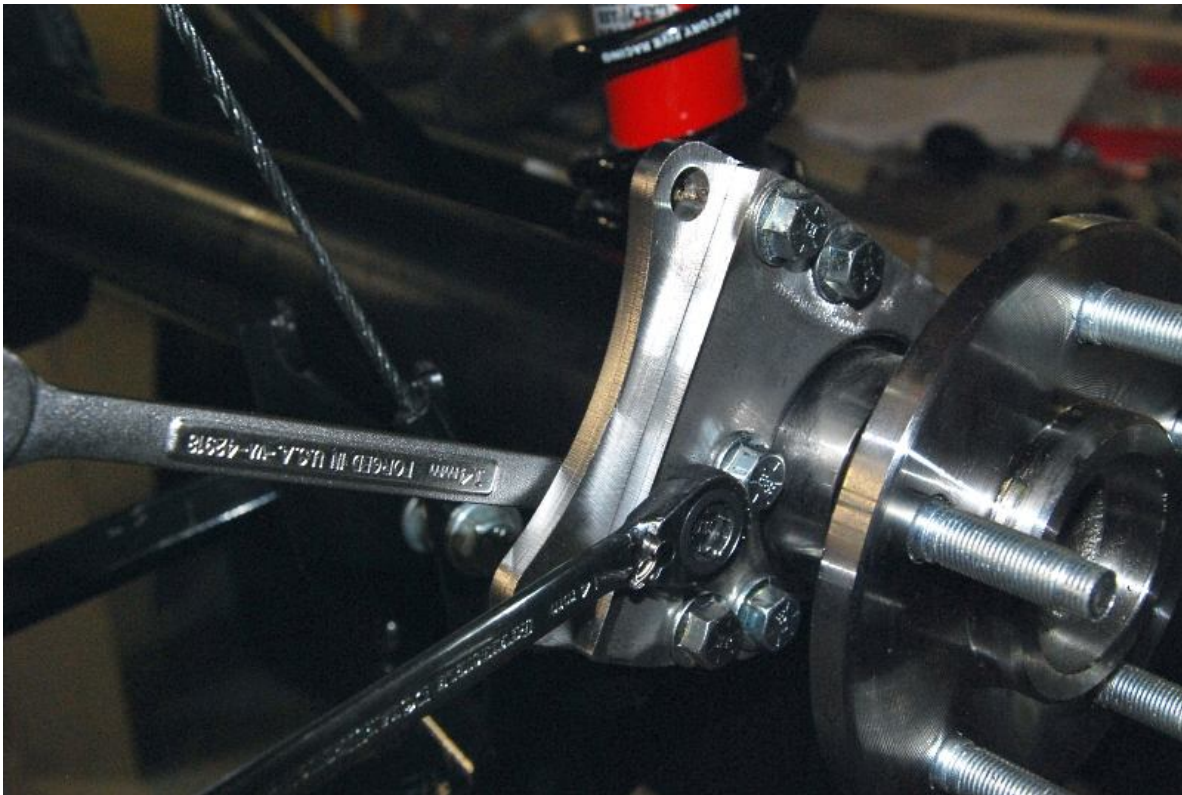

Torque the mounting bolts to the same 45-50 ft-lbs.

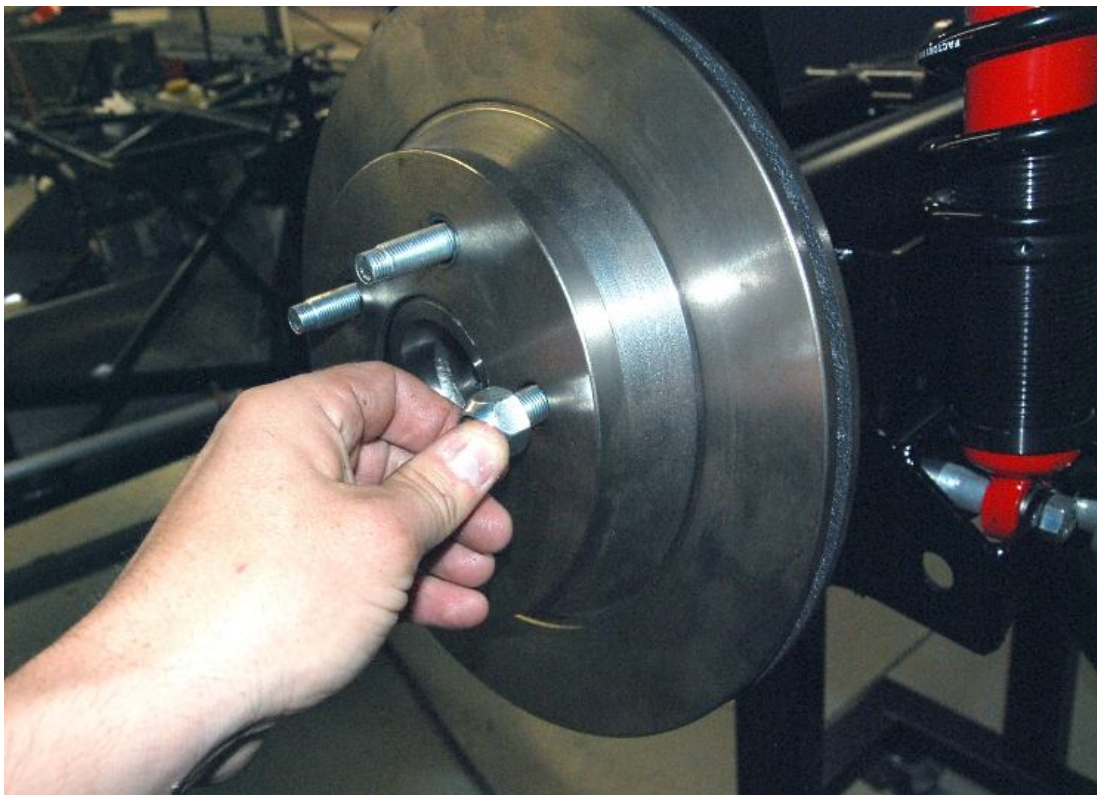

Next install the brake rotor using one lug nut to hold it in place. Make sure to clean the surface of the rotor with brake parts cleaner before installing the caliper.

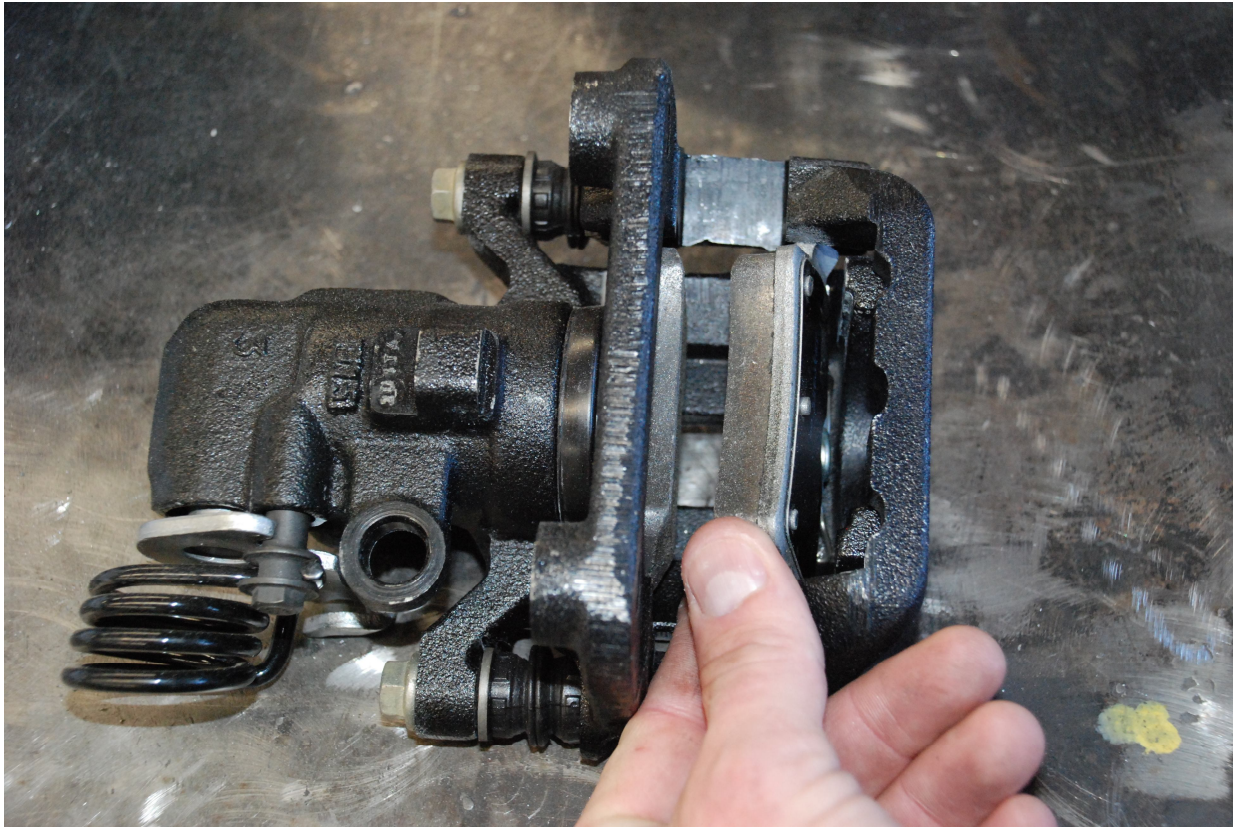

Put the brake pads in the caliper by pushing down on the pad to compress the wire springs on the top of the pad, and then slide them into the slots in the caliper bracket.

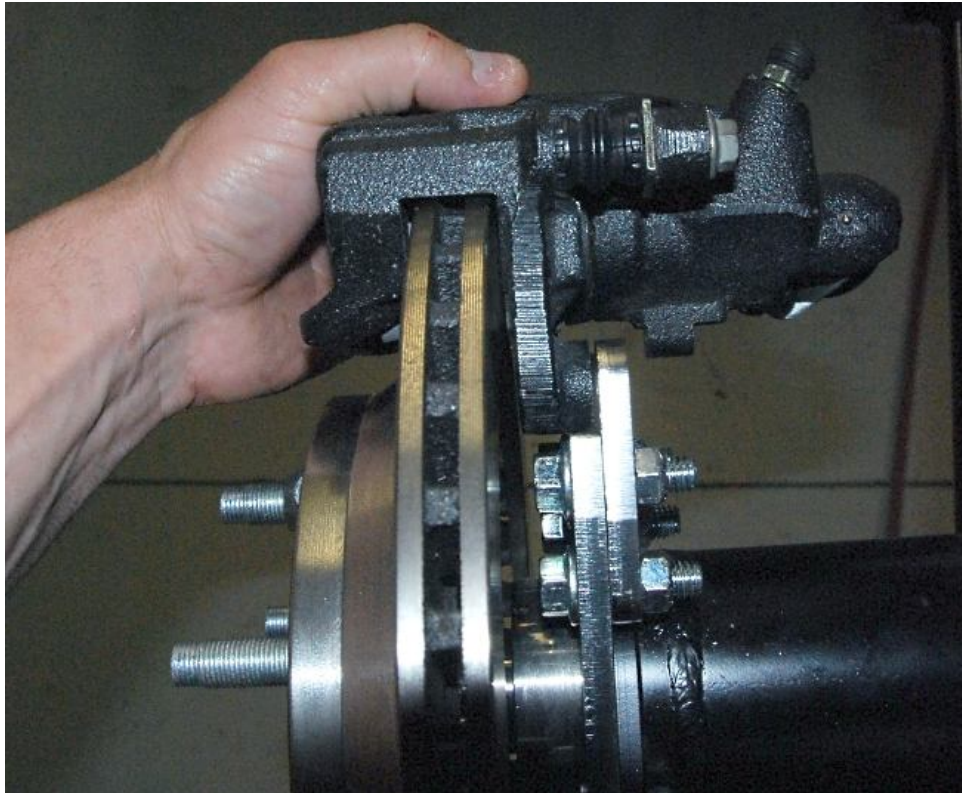

When installing the caliper make sure that the brake fluid bleed screw is on the top side of the caliper. Do not worry about the LH/RH markings on the calipers.

Make sure the caliper bracket is centered over the rotor then check to see if a spacer is needed between the caliper bracket and the caliper mount bracket.

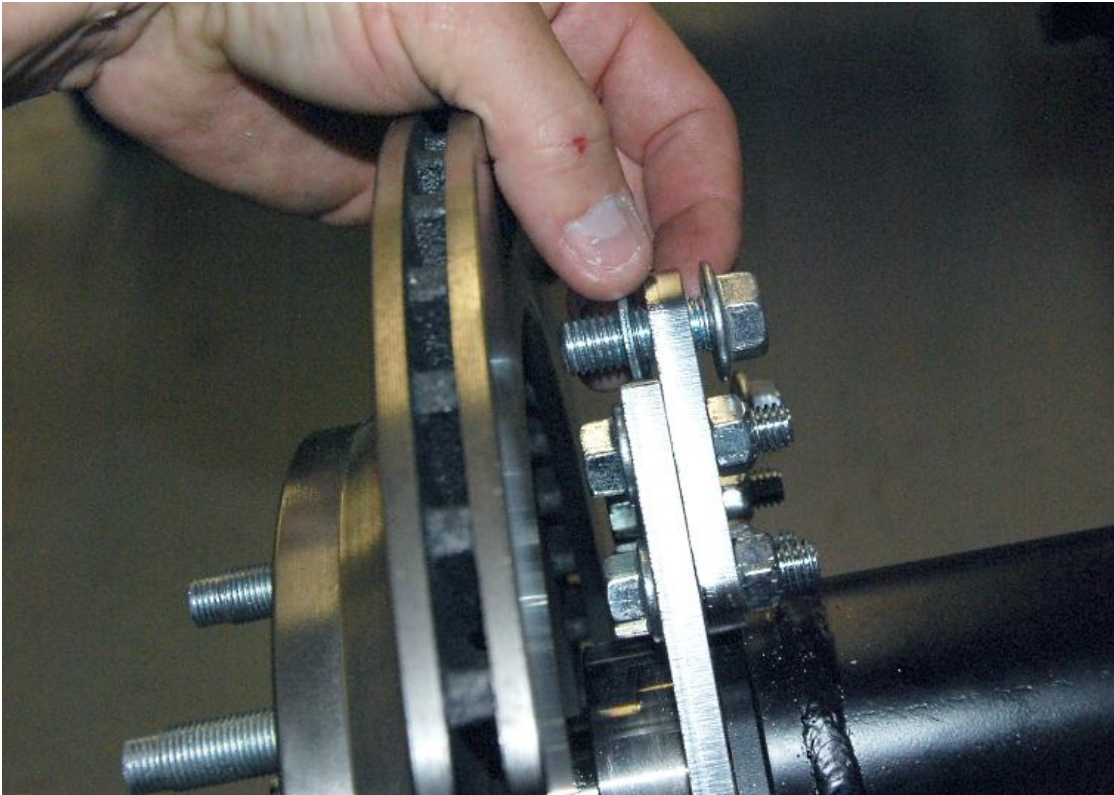

If needed remove the caliper and slide the shim onto the bolt.

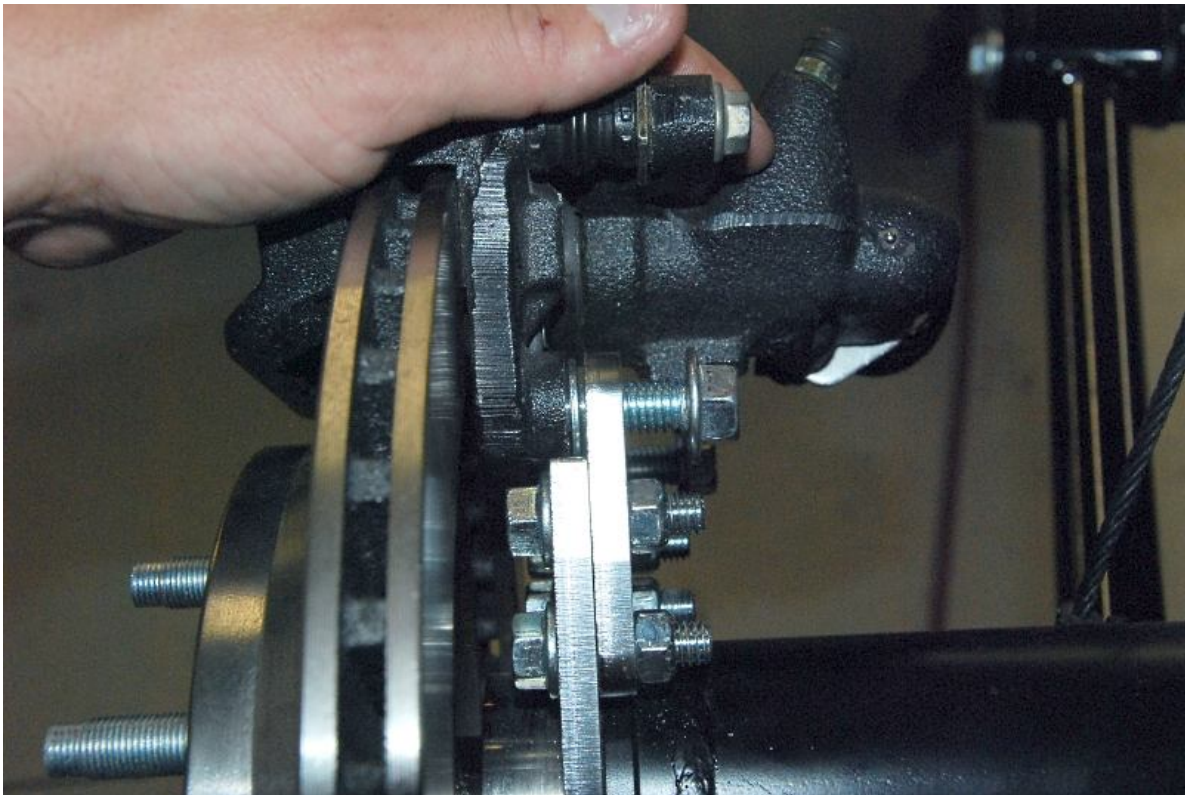

Recheck the clearance between the caliper bracket and rotor.

Tighten and torque the two 12mm mounting bolts to 55ft/lbs using a 16mm socket.

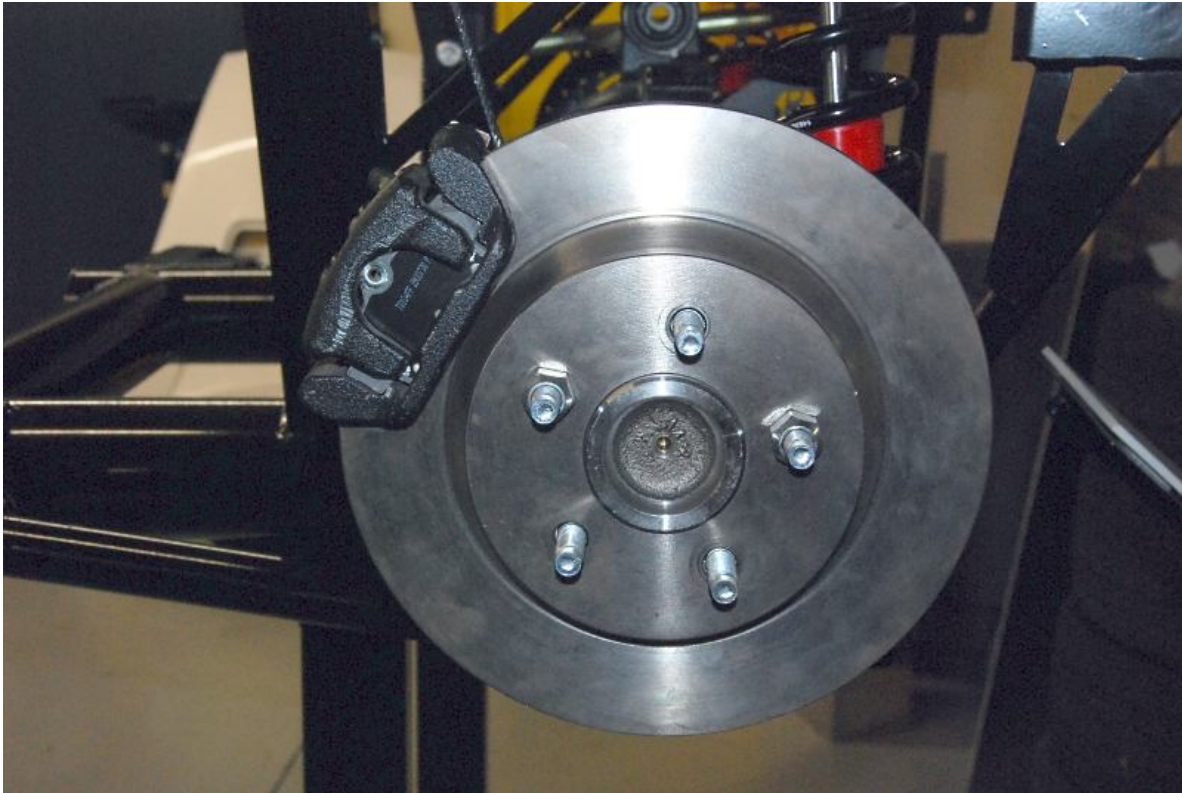

If not already done, fill the rear axle with fluid and seal the cover with RTV silicone.

Torque Specifications:

FASTENER	TORQUE (FT./LBS.)
DIFFERENTIAL PINION SHAFT LOCKING BOLT	15-30
BANJO BOLTS	30-40
WHEEL NUTS	85-105
AXLE ADAPTER/REARBACKING PLATE BOLTS	45-50
AXLE HOUSING COVER BOLTS	25-35
AXLE FILL PLUG	15-30
CALIPER MOUNTING BOLTS	70-95