



Controlled Documentation

Part Number: 33658

Revision: M

Effective Date: 1/16/19

By: J. INGERSLEV

Hot Rod A/C

INSTALLATION INSTRUCTIONS

Tools required	2
Supplies needed	2
Parts preparation	2
Evaporator.....	2
Compressors.....	4
Coyote Compressor	5
Installation.....	7
Coyote Compressor	7
Condenser Installation	15
Evaporator Installation	26
Bulkhead fittings.....	28
Hoses and fittings – Inside.....	30
Drier	37
Hoses and fittings – Engine Bay	42
Heater Control valve	47
Final hose installation	55
Inside.....	57
Engine bay A/C	59
Air ducts.....	61
dash	61
Defroster	68
Wiring.....	75
Trinary switch	75
Heater control valve	79
Fan	83
Evaporator motor	86
Control panel.....	88
Testing	101
Hose insulation	101
Hose Diagram	103
Wiring diagram.....	104

Tools required

- ✂ Philips head screwdriver, $\frac{3}{8}$ " , $\frac{7}{16}$ " , $\frac{3}{4}$ " , $1\frac{1}{16}$ " wrench, 8mm, $\frac{5}{16}$ " , $1\frac{1}{8}$ " socket, ratchet, drill, $\frac{7}{8}$ " hole saw, $\frac{3}{16}$ " , $\frac{13}{64}$ " , $\frac{1}{4}$ " drill bits, $\frac{1}{8}$ " , $\frac{5}{32}$ " hex keys, rivet tool, large clamps, $\frac{5}{16}$ " nut drive, razor knife, bucket, pliers, wire strippers, wire crimpers, soldering iron, solder, marker, masking tape, tape measure, ruler.
- ✂ A/C hose crimping tool (possible loaner tool at auto parts store or available online from Vintage Air or www.etooldirect.com Mastercool 71550 Manual hose crimper)

Supplies needed

- 🚗 50/50 Coolant, (2) 12oz 134a Refrigerant cans, (1) 12oz 1st charge (has oil in it), blue Loctite, silicone
- 👉 It is a lot easier to get to all of the parts before the body is put on the frame. Connect and ensure that the A/C system runs correctly (charged and blows cold) before putting the body on.

Parts preparation

EVAPORATOR

Silicone around the gap where the duct end cap attaches to the evaporator

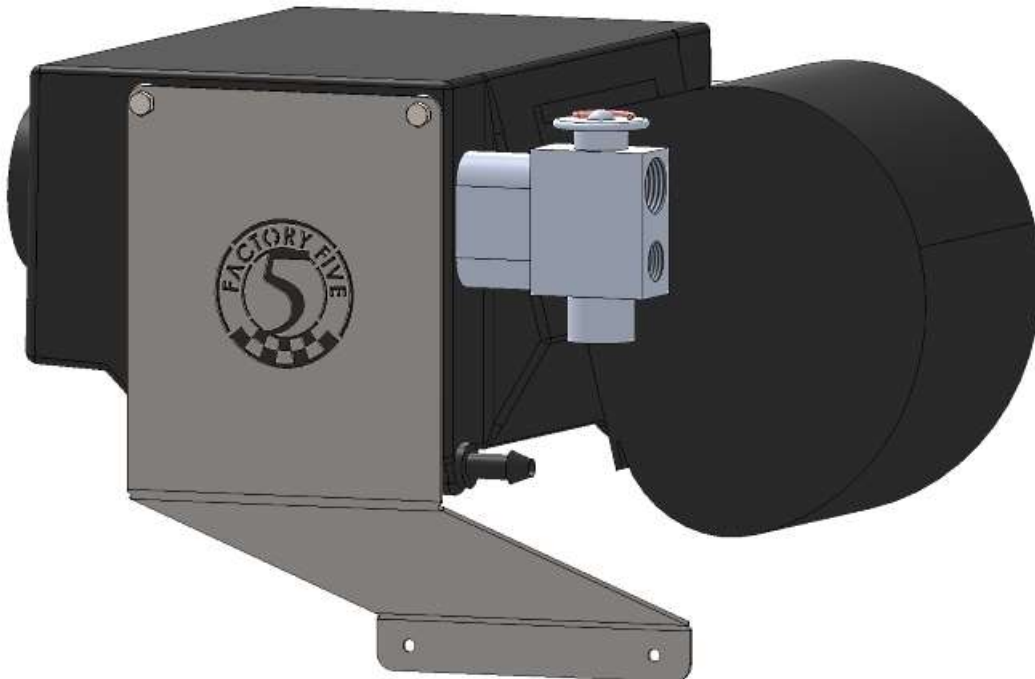

Attach the larger mounting brackets to the side of the A/C evaporator closest to the A/C regulator as shown using an 8mm socket.

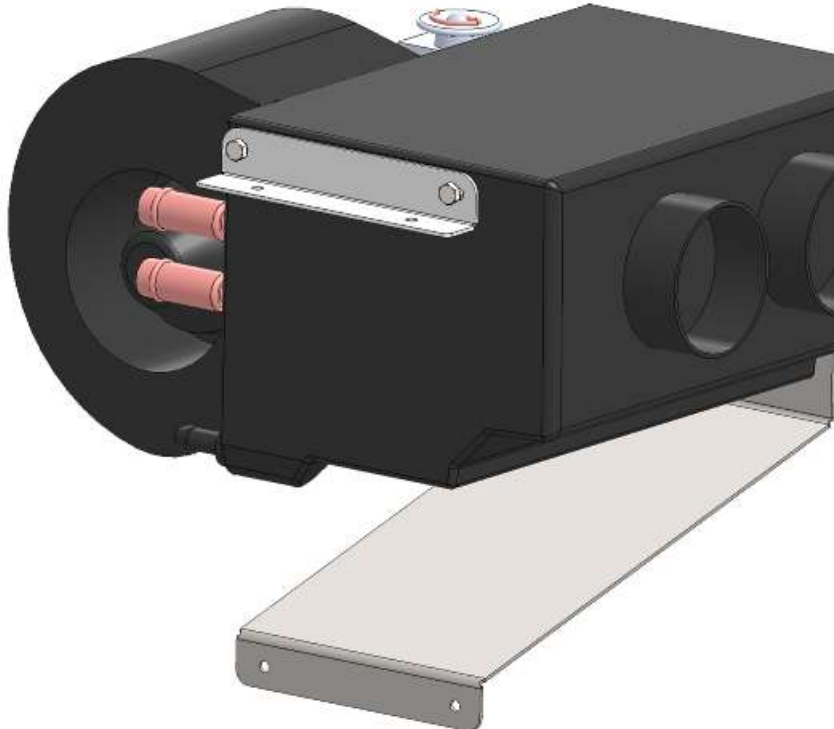

Attach the smaller mounting bracket to the other side of the A/C evaporator as shown using an 8mm socket.

COMPRESSORS

302/351

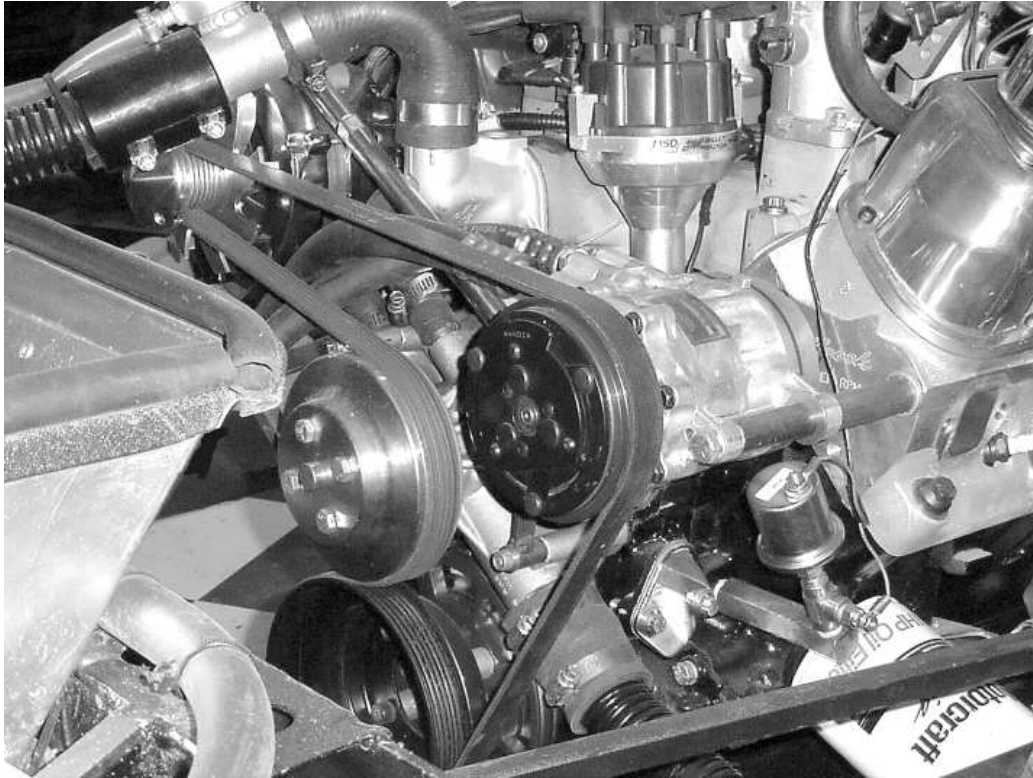

Factory five has a compressor and steel brackets available for the 302/351 engine that will mount it to the top left side of the engine

Coyote



Factory Five offers a compressor that will bolt onto the Coyote engine on the bottom right side of the engine.

COYOTE COMPRESSOR



Cut the aluminum section marked above off the compressor.

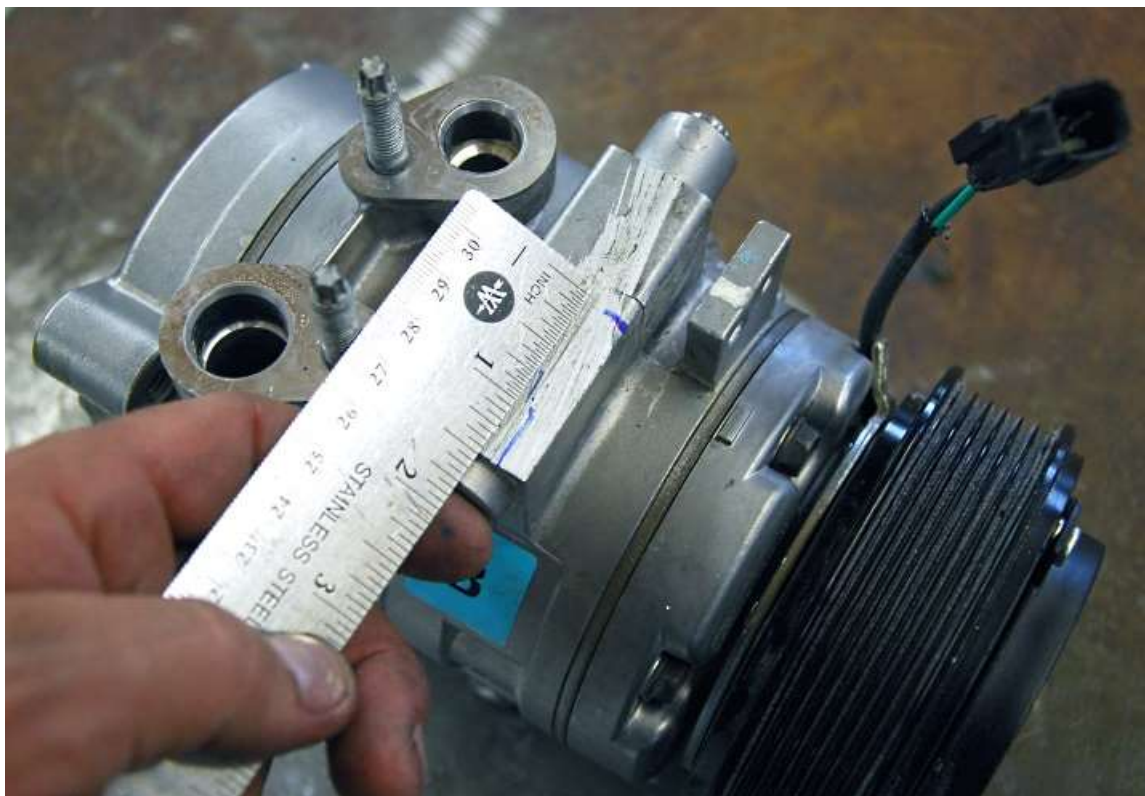

Measure and mark 1.50" x 0.375" wide on the area just cut.

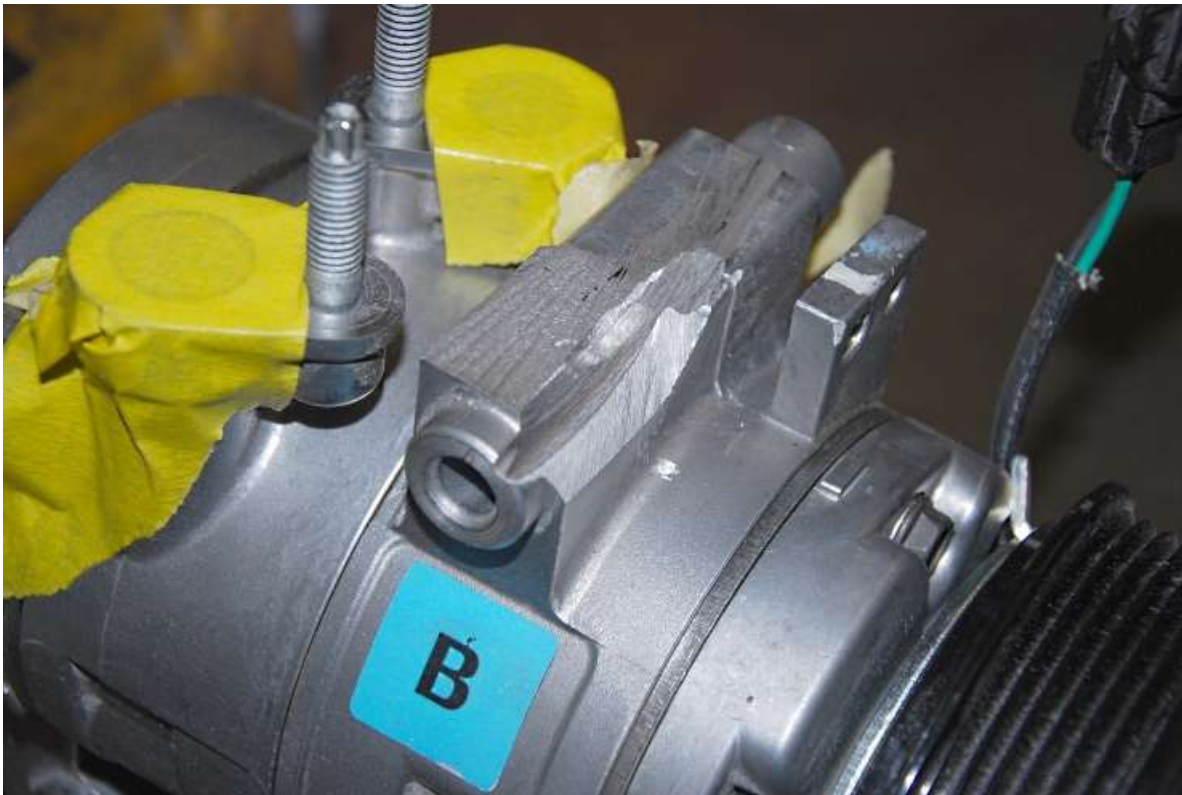

Cut or grind the area down so that the cut just goes into the top of the bolt head area as shown. This is for upper control arm mount and bolt clearance.



Do not install the compressor until after the engine is in the frame.

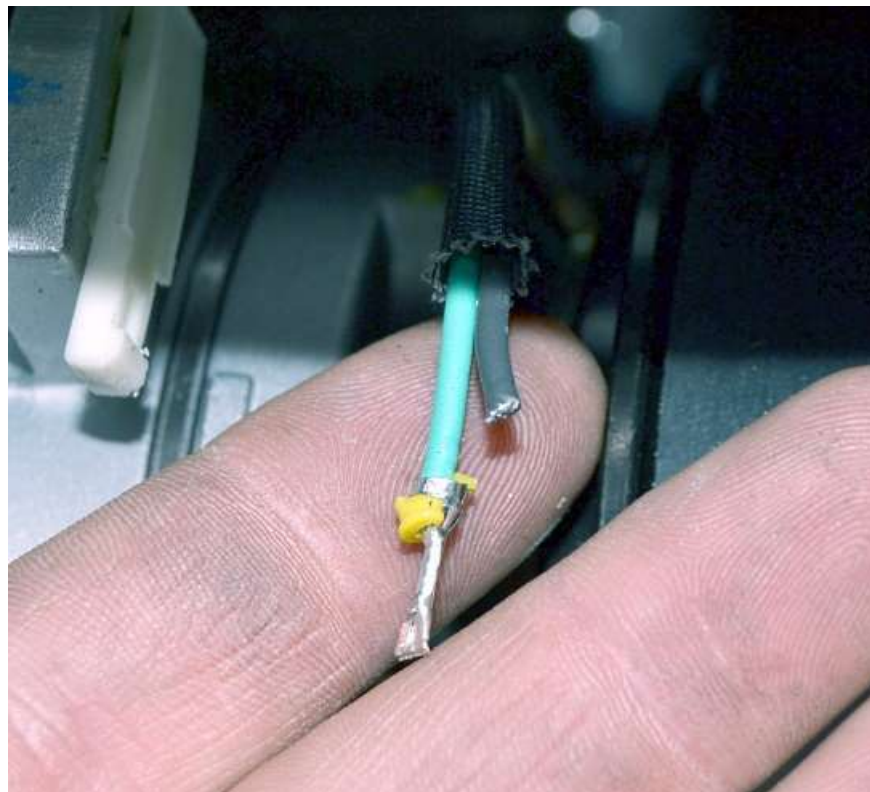

Cut the connector off the compressor.

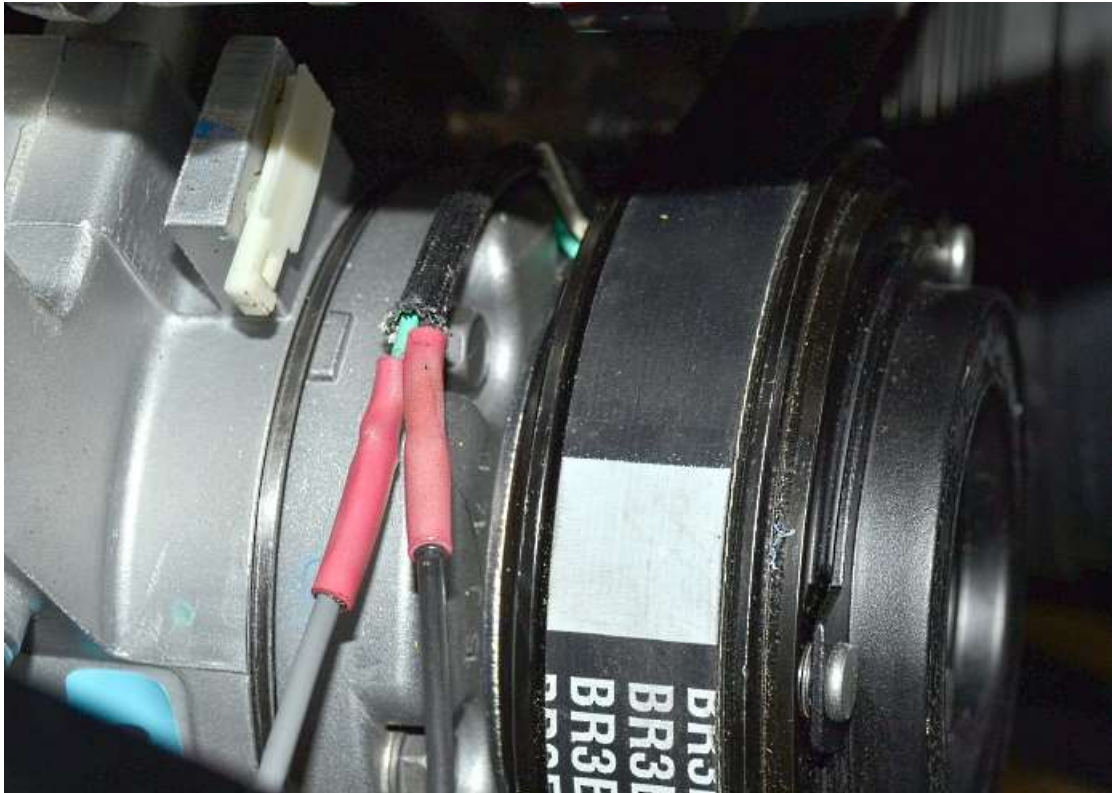

Connect a 2' section of gray wire to the green compressor wire and a 6' section of black wire to the black compressor wire.

Installation

COYOTE COMPRESSOR



Cable tie, belt



ratchet, socket, extension, wire cutter.



The belt used is a special elastic belt that is designed to stretch for install and then keep the correct tension which is why Ford does not use a belt tensioner on the A/C belt.

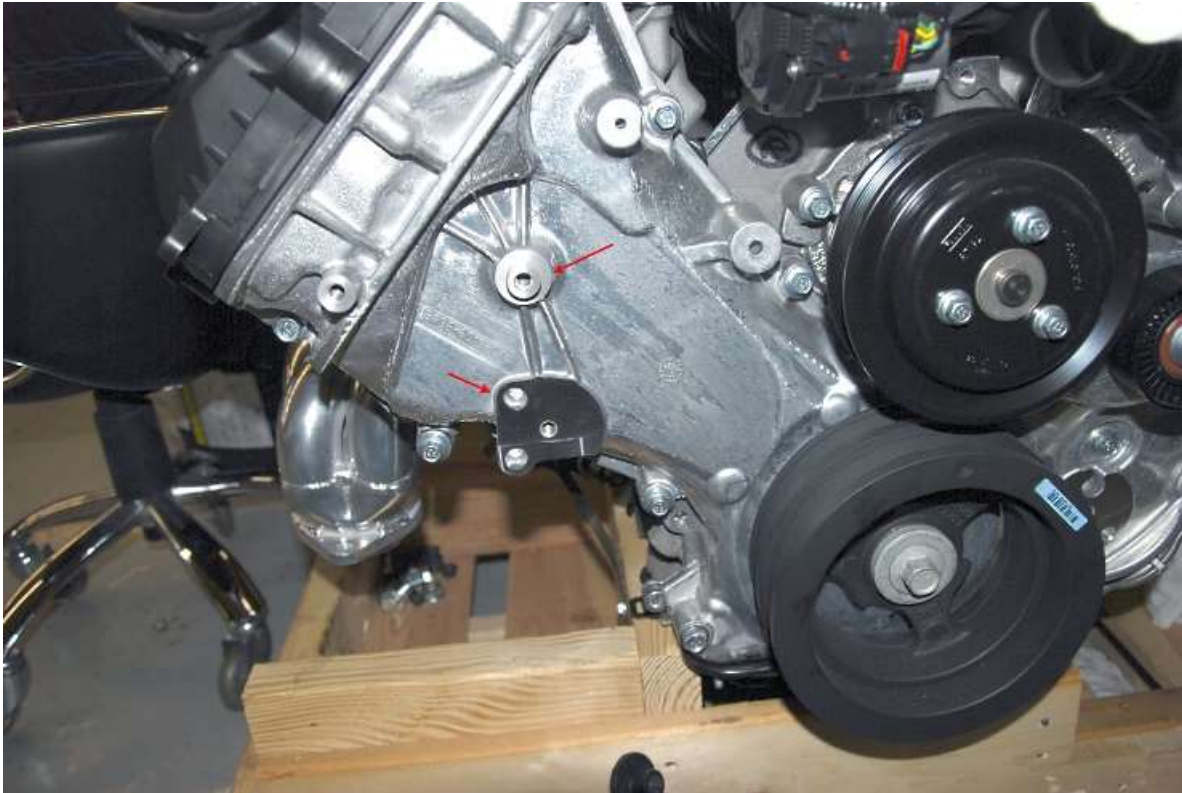

If your timing chain cover has a machined boss and mount area below it as shown above, this is the set-up used by the F150 Coyote which does use a tensioner. The Alternator bracket is not designed to use the truck set-up. It is recommended to use the Mustang set-up.



Use a 15mm socket and ratchet to loosen the belt tensioner and remove the belt from the tensioner.

Remove the alternator if installed.



Put the long bolts and washers in the lower compressor mounting holes.



Cover the bolts with masking tape so they stay in.



Install the compressor on the lower right side of the engine attaching it to the block using the top mounting hole; a long bolt and washer. Make sure the plug and wires stick up and are not pinched by the engine.

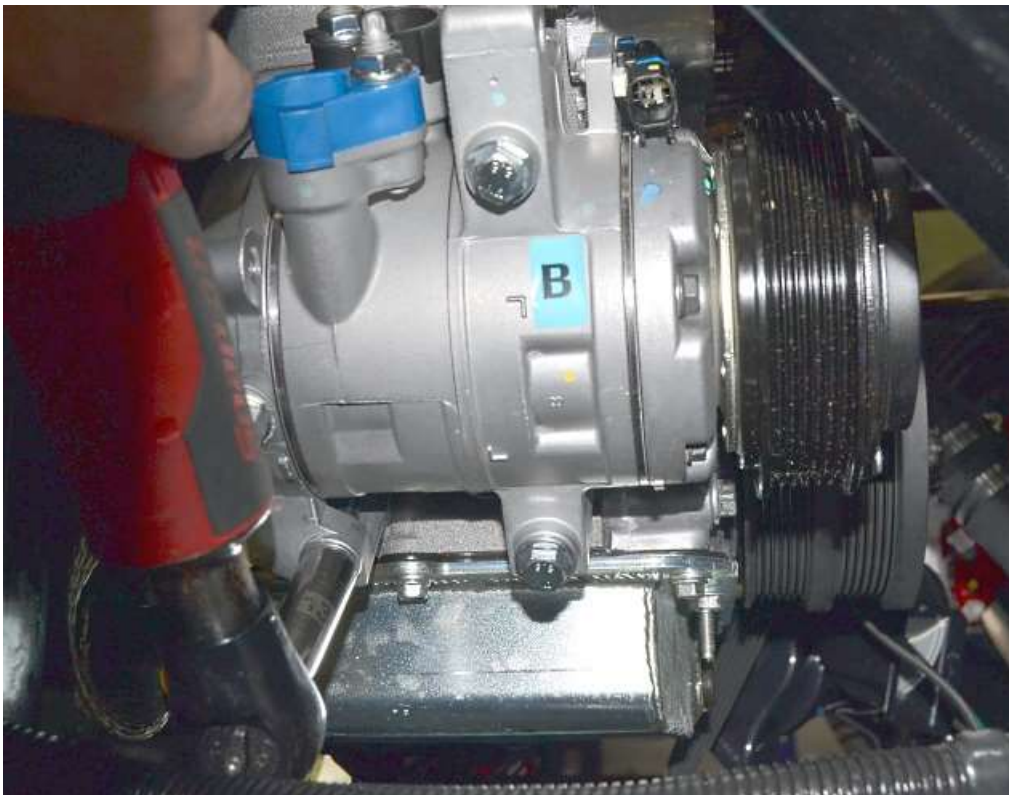

Attach the lower two mounting bolts then torque the bolts to **15Nm (11lbf)**.

Check the clearance to the upper control arm mount brackets, there should be $\frac{3}{16}$ " or more.



Put the A/C belt behind the crankshaft pulley with the accessory drive belt ribs facing towards the front of the vehicle and the belt on the A/C compressor.



Feed a cable tie through the crankshaft pulley spokes, up and over the A/C belt and tighten the cable tie.



Make sure the belt is above the oil pan flange otherwise the belt or engine could get damaged.

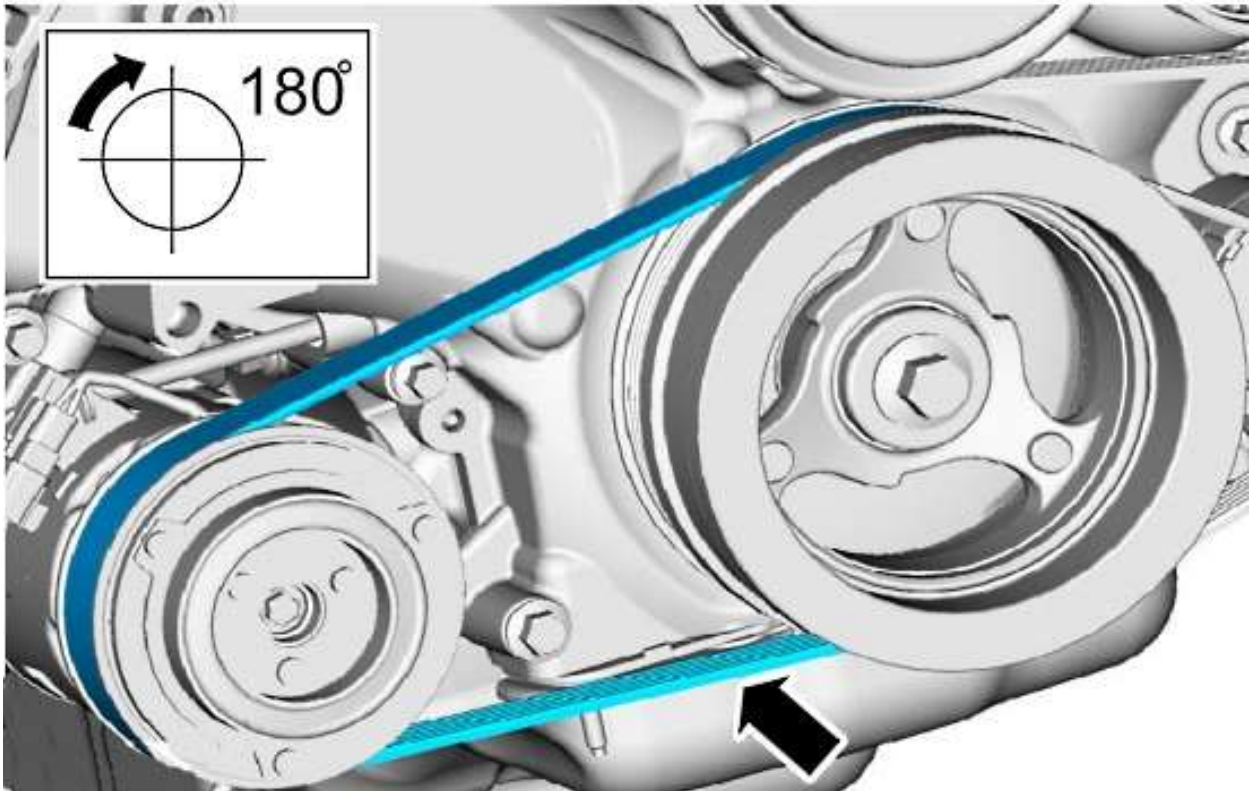

Use a socket and ratchet to turn the crank over 180° so the belt is seated on top of the crank pulley.

Cut and remove the cable tie.

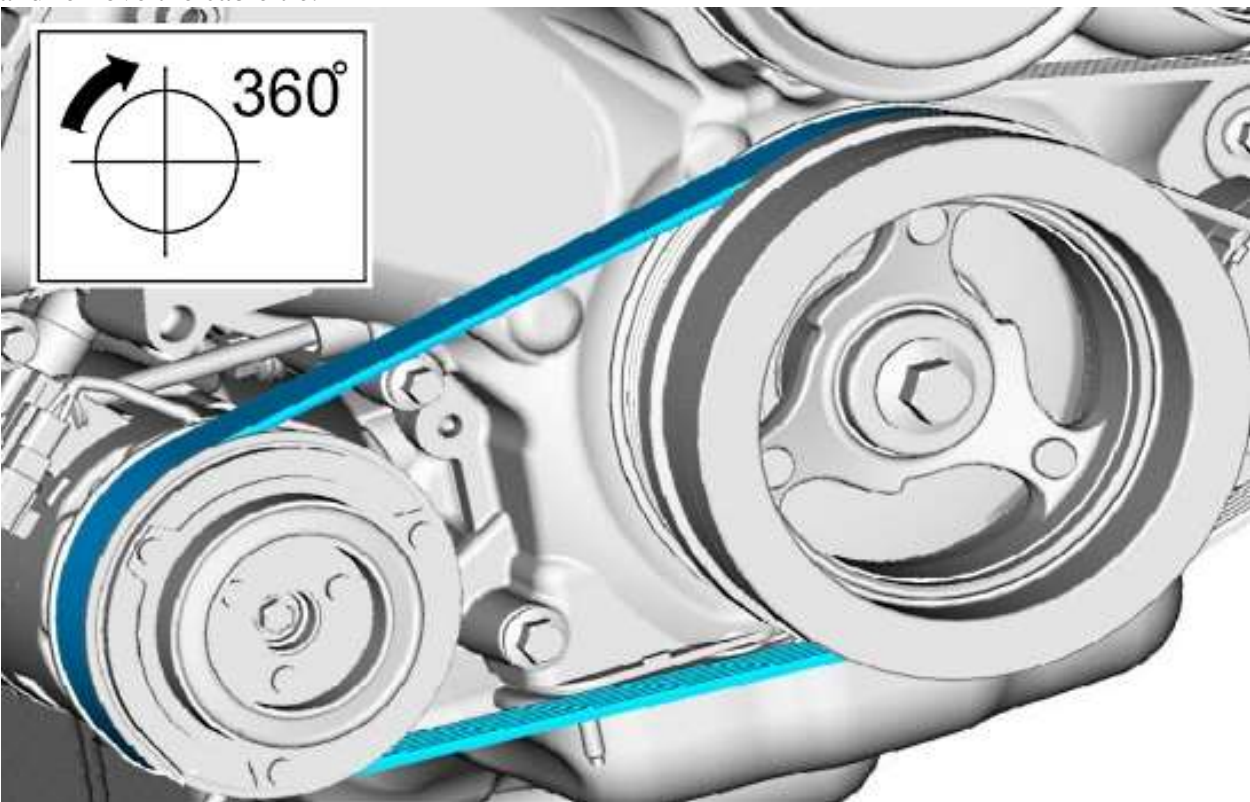

Rotate the engine 360° to make sure that the belt is fully seated all the way around the crank pulley.



Lubricate the green O-ring and surface of the adapter blocks.



Use a 13mm socket and ratchet to tighten the blocks to the compressor.



Reattach the alternator and bracket to the engine making sure to keep the wiring harness in front of the bracket.



Reinstall the main serpentine belt.

CONDENSER INSTALLATION

Some pictures show the Hot Rod radiator, installation is similar for the Truck.

ITEM NO.	PART NUMBER	DESCRIPTION	QTY.
1	33670	14"x20" CONDENSER	1
2	34105	UPPER CONDENSER MOUNT	2
3	34106	34107 - CONDENSER MNT. LWR. LEFT	1
4	34106	34108 - CONDENSER MNT. LWR. RIGHT	1
5	34109	#8 HARDLINE	1
6	34110	#6 HARDLINE	1

REV.	REVISION DESCRIPTION	DATE	APPROVED
A	INITIAL RELEASE	8/18/09	

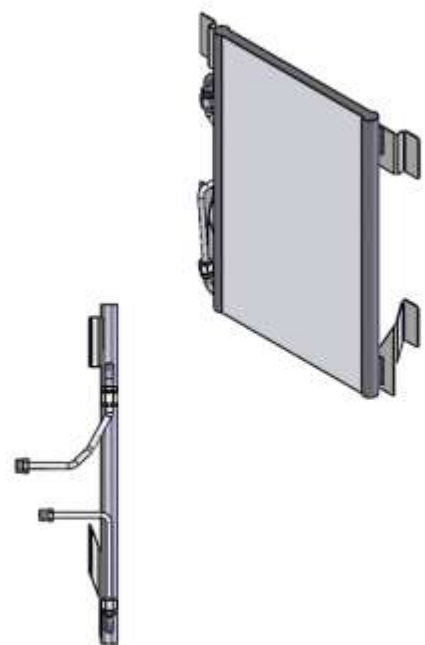
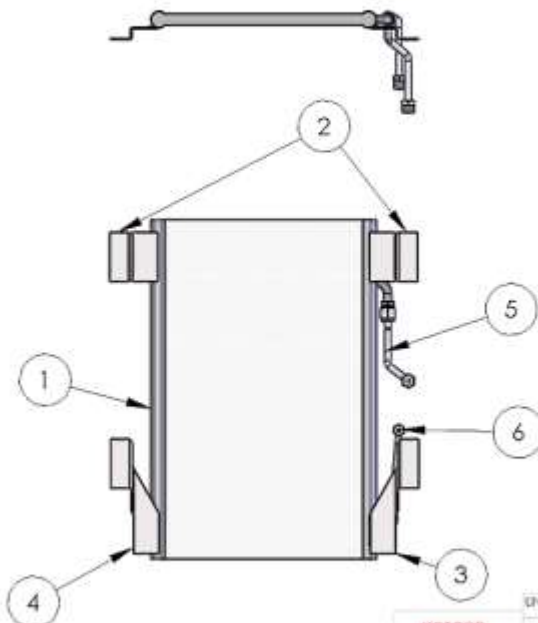

PROPRIETARY AND CONFIDENTIAL
 THE INFORMATION CONTAINED IN THIS DRAWING IS THE SOLE PROPERTY OF FACTORY FIVE RACING, INC. ANY REPRODUCTION IN PART OR AS A WHOLE WITHOUT THE WRITTEN PERMISSION OF FACTORY FIVE RACING, INC. IS PROHIBITED.

UNLESS OTHERWISE SPECIFIED:	
HOT ROD	DIMENSIONS ARE IN INCHES
35 TRUCK	TOLERANCES:
	TWO PLACE DECIMAL ±0.01
	THREE PLACE DECIMAL ±0.005
	FOUR PLACE DECIMAL ±0.001
	MATERIAL:
	FINISH:
BASED ON:	DRAWN:
AFFILIATION:	CHECKED:
	ENG. APPE.
	MFG. APPE.
	Q.A.
	COMMENTS:
	DATE:
	NAME:
	DATE:
	1/11/2019

Factory Five Racing, Inc.

TITLE: **A/C CONDENSER BOX**

SIZE: **A** DWG. NO.: **33675** REV: **A**

SCALE: 1:8 WEIGHT: SHEET 1 OF 1

If installed, remove the radiator and grill from the frame.
 Place the radiator face up on a work surface using a block of wood under the radiator mount tabs so that it sits flat.



Place and center the A/C Condenser on the front of the Radiator so that the top edge of the Condenser sits on the Radiator fins and the bottom edge of the condenser is up on the lower tank. Note the location of the fittings on the Condenser, the larger #10 fitting is towards the top of the radiator.



The mount brackets will not sit down flush on the radiator; they will be spaced away from it.



Place the Condenser mounting brackets on the radiator and under the condenser so that the smaller tab on each of the mount is positioned over the correct radiator mount tab. The strange looking brackets are for the bottom.



Mark the centers of the Condenser mount holes on the mounting brackets using a marker.



Remove the mount brackets and drill $\frac{1}{8}$ " holes at the locations marked.

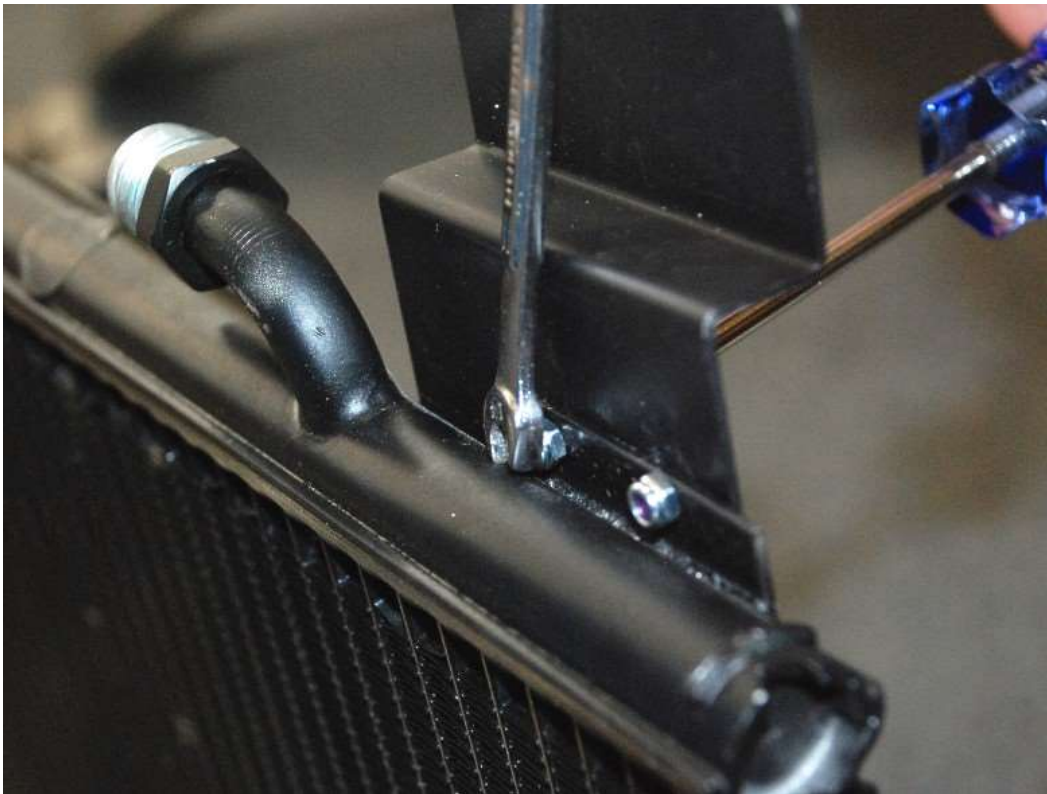

Use the supplied 4-40 x $\frac{5}{16}$ " screws and lock nuts to attach the brackets to the Condenser. Do not fully tighten the screws; leave them so that the brackets can get moved slightly. Use a $\frac{1}{4}$ " wrench and Philips head screwdriver. Note the direction the screws are inserted.



Place the Condenser on the radiator and adjusting the brackets if needed. Once the brackets are correct, remove and fully tighten the screws.



With the Condenser on the radiator, turn the radiator over and use a 1/4" drill bit through the radiator mount holes to mark the location of the holes on the Condenser mount brackets.



Remove the Condenser from the radiator and use a small drill bit and a wood block to drill the locations marked then open them up with a ¼" bit.



Place the Condenser on the grill and check clearance between the grill crossbar and the Condenser.



Push on a #8 O-ring on the end of the large #8 hard line and lubricate with the small tube of oil.



Attach the large #8 hard line to the Condenser using $\frac{7}{8}$ " and $\frac{3}{4}$ " wrenches so that the fitting on the end is 90° to the condenser.



Push on a #6 O-ring on the long end of the large #6 hard line and lubricate with the small tube of oil.

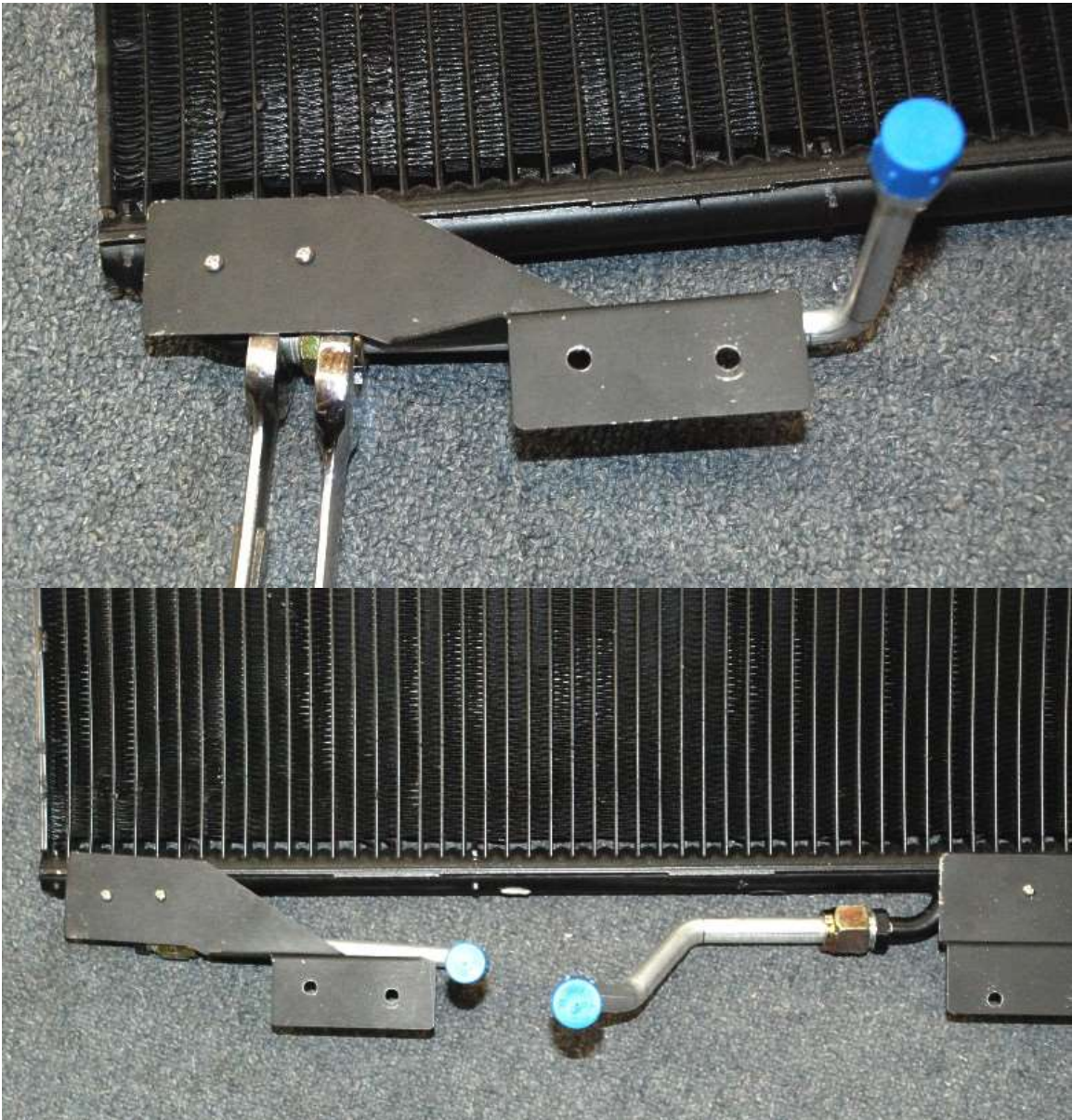

Attach the smaller #6 hard line to the Condenser using $\frac{3}{4}$ " and $\frac{11}{16}$ " wrenches so that the fitting on the end is 90° to the condenser.

Place the Condenser on the Grill aligning the mount plate and Grill tab holes.



Please the $\frac{7}{16}$ " aluminum spacers on the lower Condenser mount holes.



Hot Rod - Place the hood Hinge mount plates on the upper Condenser mount plates so that they are opposite from the way installed in the manual. Place one washer over the top hole and two washers over the lower hole.



Truck - Place the hood Hinge mount plates on the upper Condenser mount plates then place $\frac{7}{16}$ " aluminum spacers on top of the mount plate.

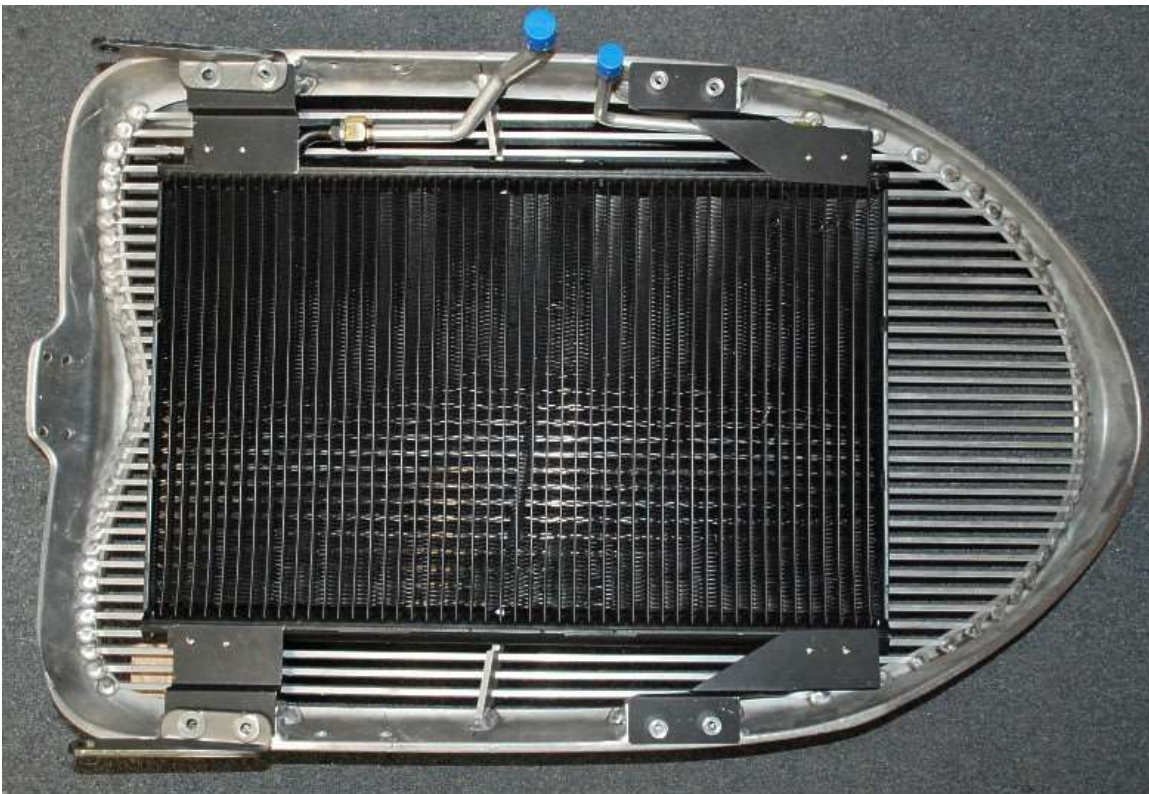

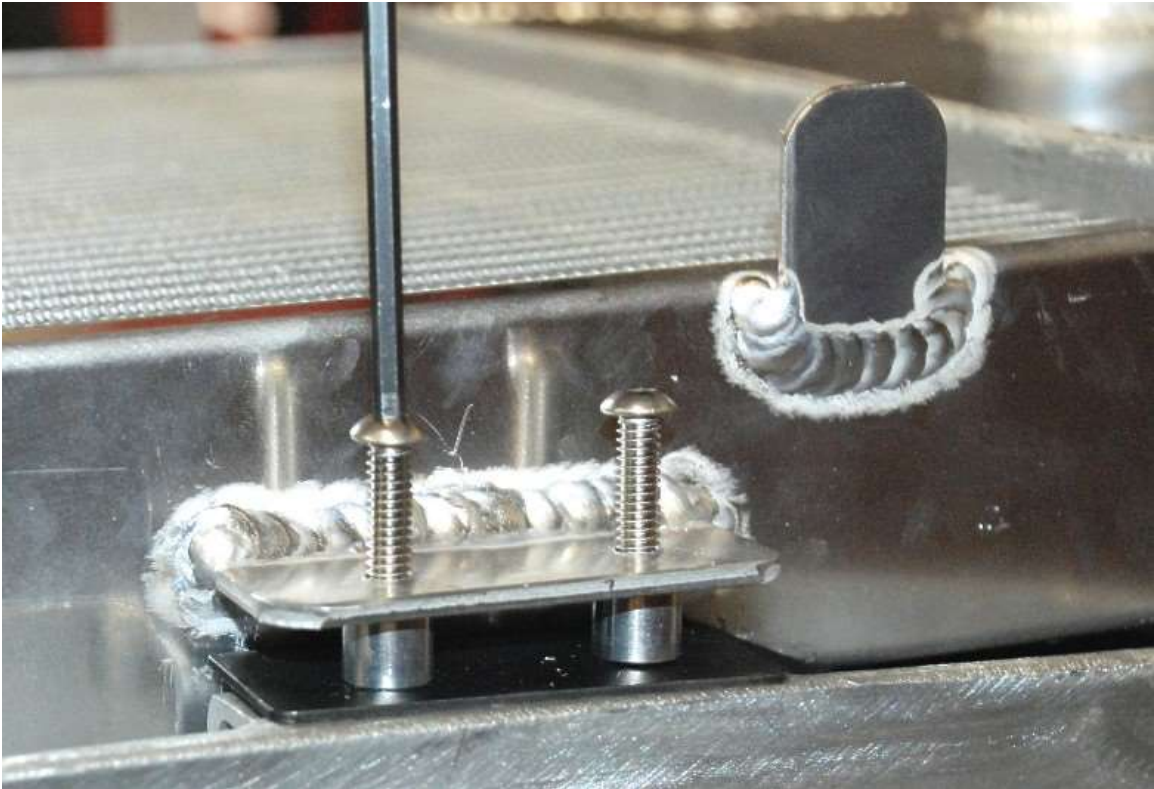

Place the radiator on top of the spacers.



Attach the Radiator and Condenser to the grill using the $\frac{1}{4}$ "-20 x 1.25" screws provided. Insert and start all of the screws before tightening all of the screws.

EVAPORATOR INSTALLATION

-  Philips head screwdriver, $\frac{7}{16}$ " wrench, drill, $\frac{3}{16}$ " drill bit, $\frac{5}{16}$ " nut driver
-  A/C components

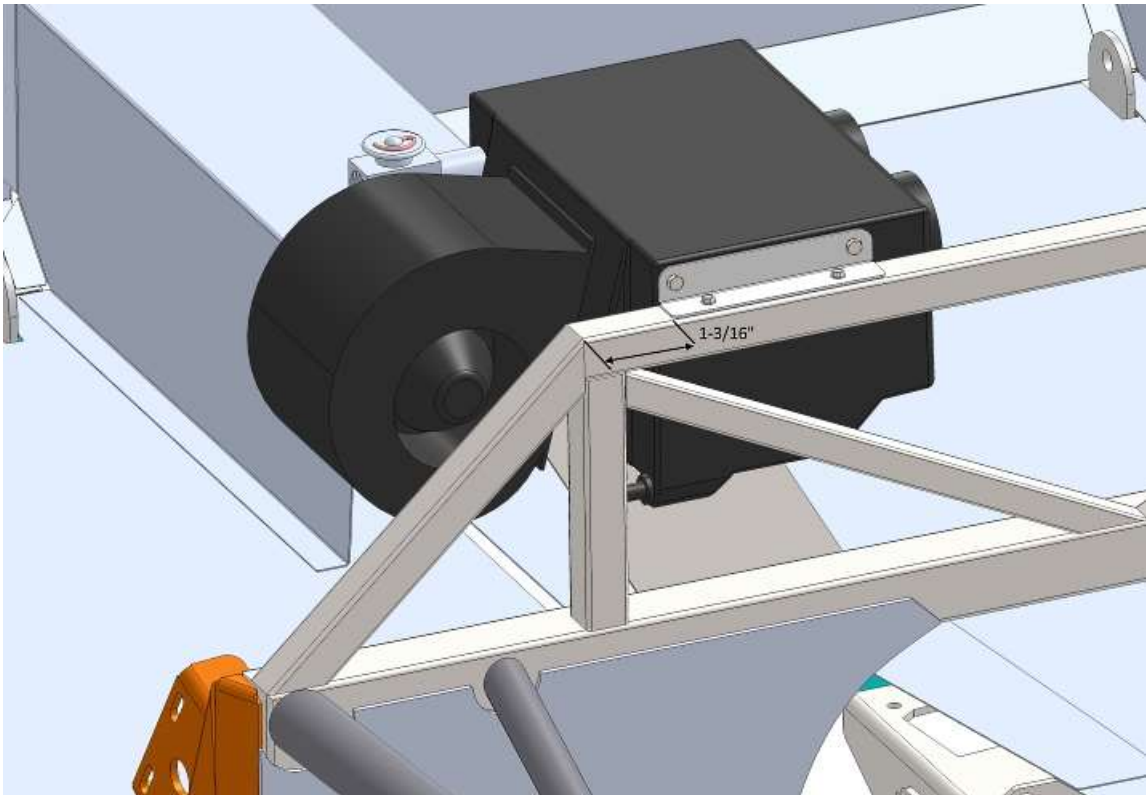

Hold the evaporator up to the frame on the right side of the firewall so that the Evaporator is oriented as shown with the small front mount on top of 1" tube and 1³/₁₆" from the end. Attach it to the frame using the included #10 x 1" self tapping screws or kit 1/4" washer head screws and rivnuts.

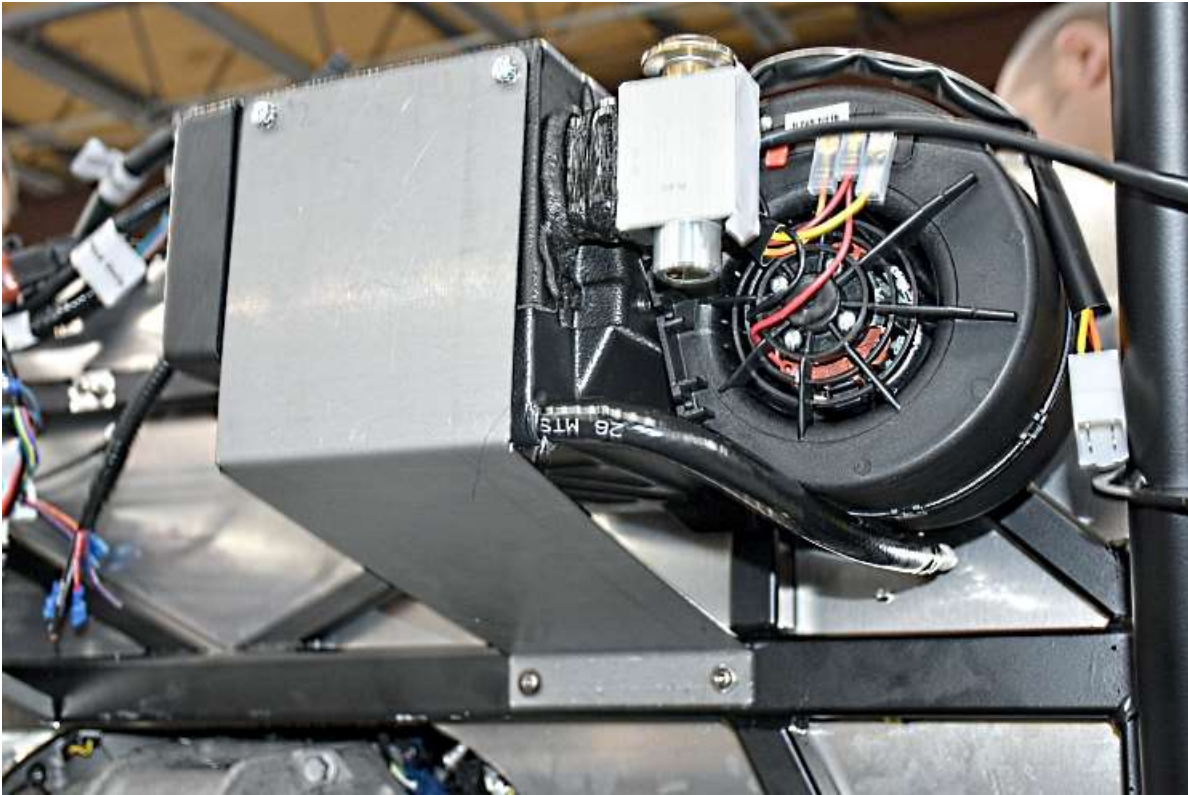

The rear mount will attach to the back side of the lower 1.50" tube and attach it to the frame using the included #10 x 1" self tapping screws or kit 1/4" washer head screws and rivnuts.

BULKHEAD FITTINGS

- ✂ 7/8" hole saw, 3/16" drill bit, drill, scissors, marker, ruler, tape, 1 1/8" socket or wrench, Loctite.
- 🔩 bulkhead fittings, A/C fittings.

Cut out the bulkhead templates from the instructions if included with them.

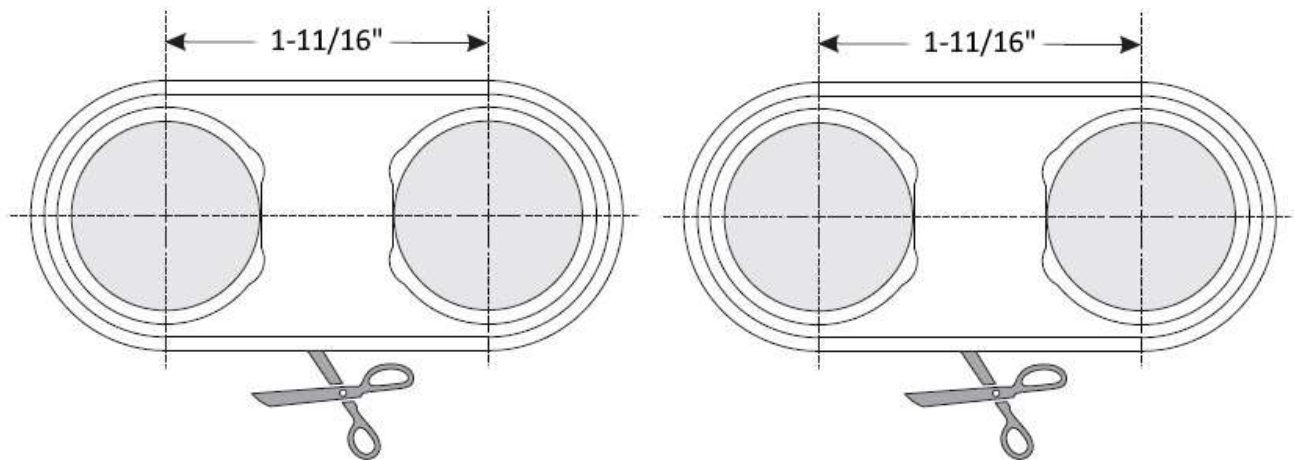

If **not** included, check the center to center measurements with the templates above. If the same use cut these templates.

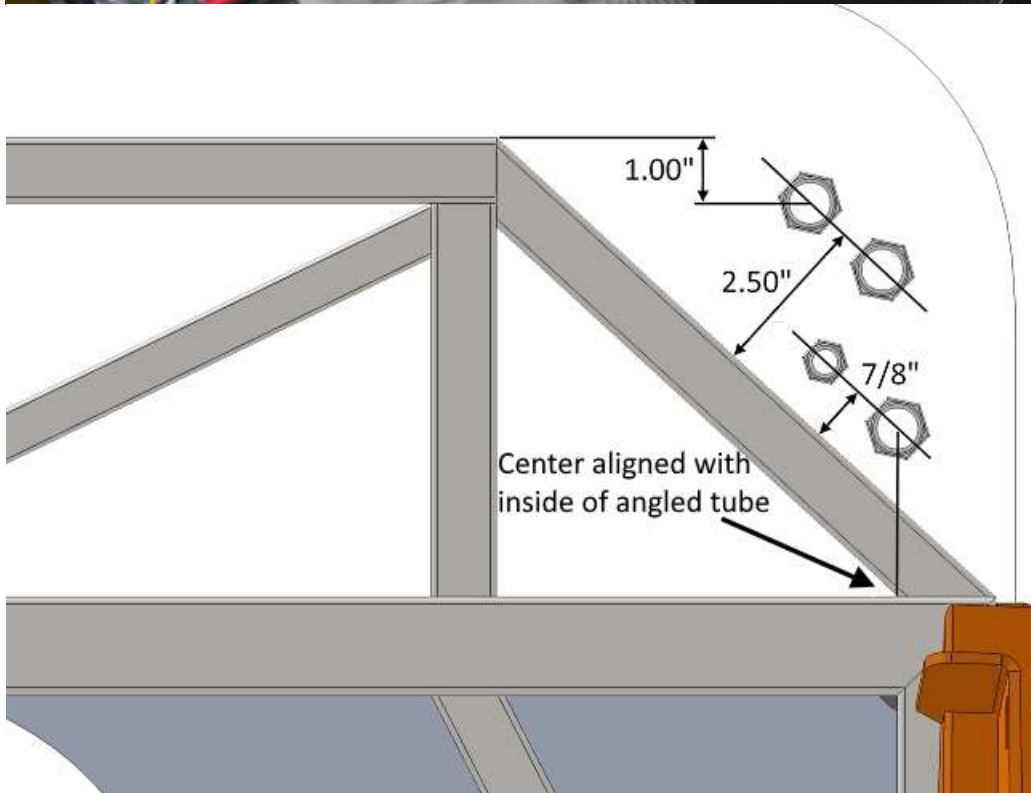

Locate the templates to the right side of the evaporator on the firewall using the dimensions above.

Drill the center locations with a $\frac{3}{16}$ " drill bit then follow up using the correct size hole saw.



This install used the top and third down for the A/C and the 2nd down and bottom for the heater core.

HOSES AND FITTINGS – INSIDE

A/C



Do not crimp any hoses until everything has been fit.

It is highly recommended that you have the A/C hoses hydraulically crimped to ensure that they are done correctly and will not leak. It is hard to get to the fittings once the body is on.

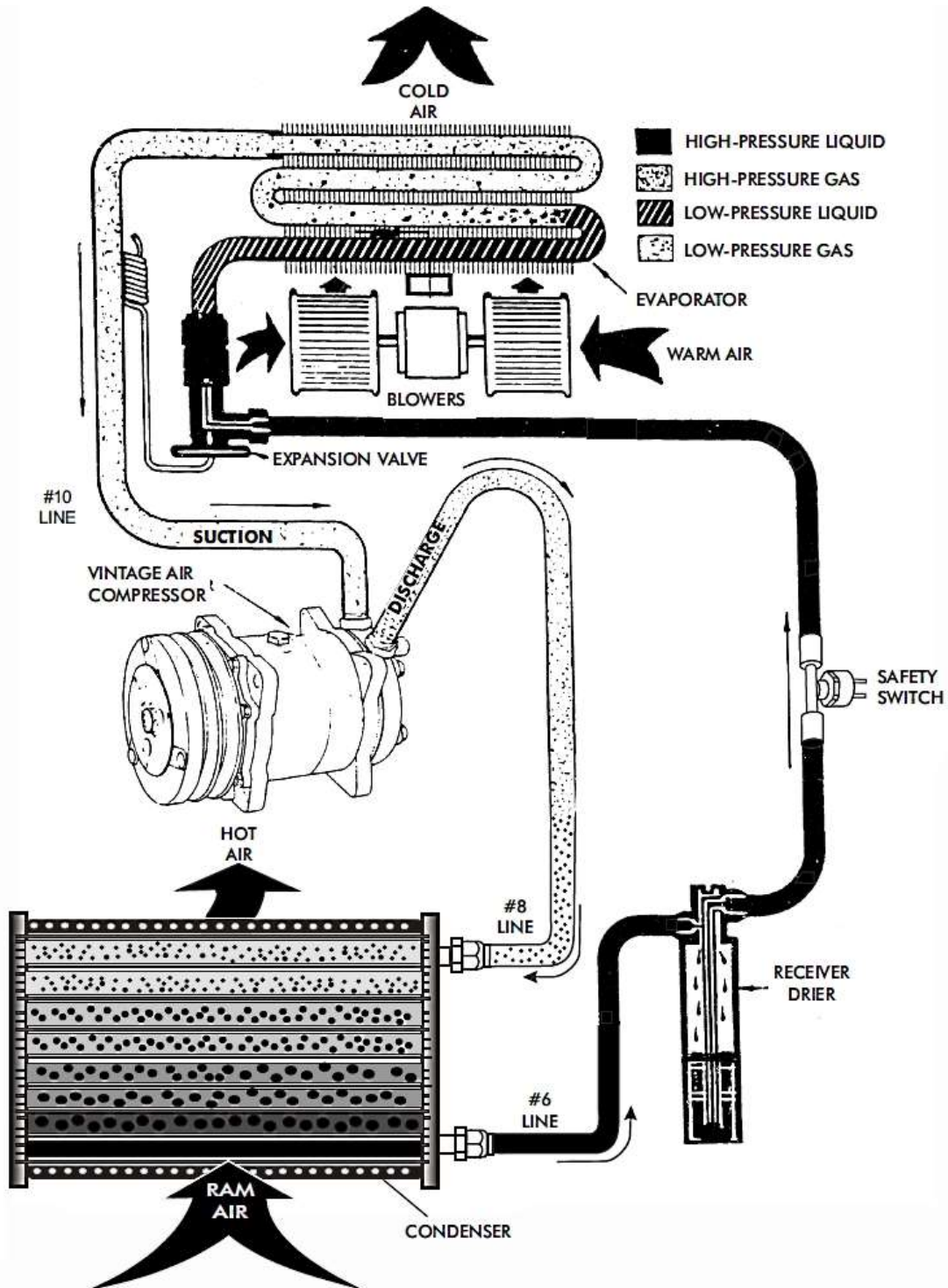

Refrigeration Flow Courtesy of Vintage Air

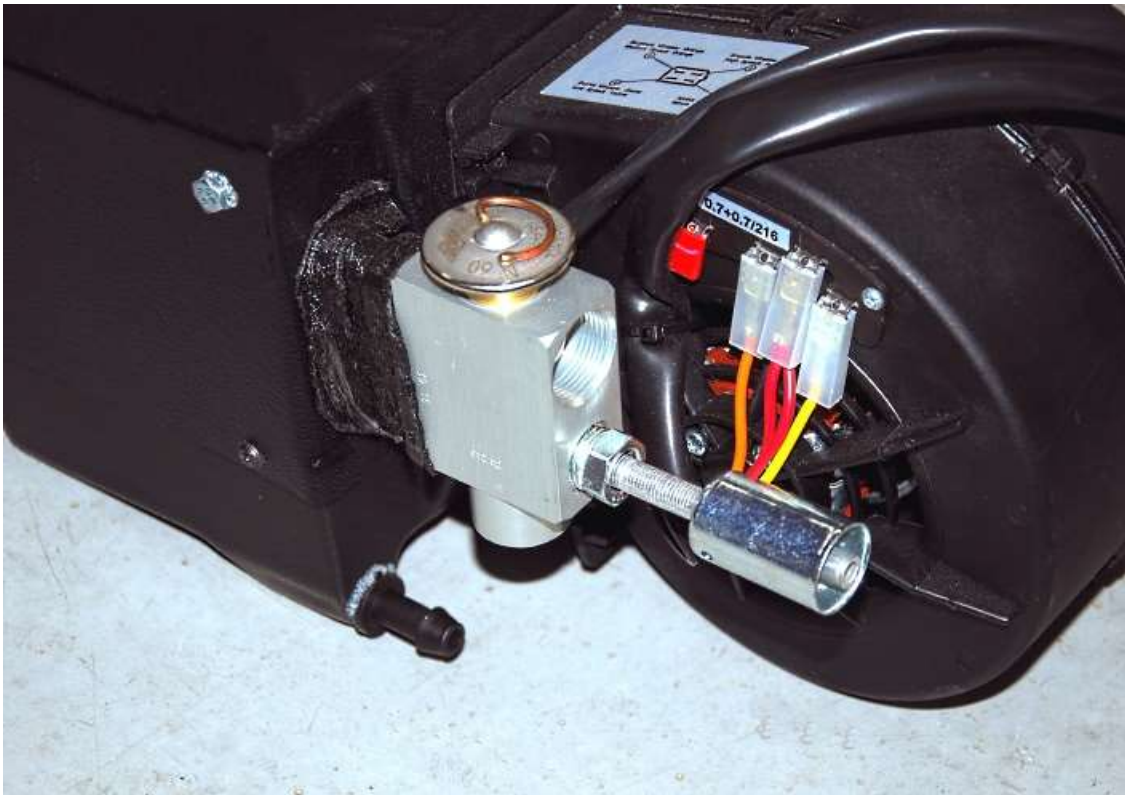

Screw the small #6 male fitting into the lower hole on the regulator block hand tight.

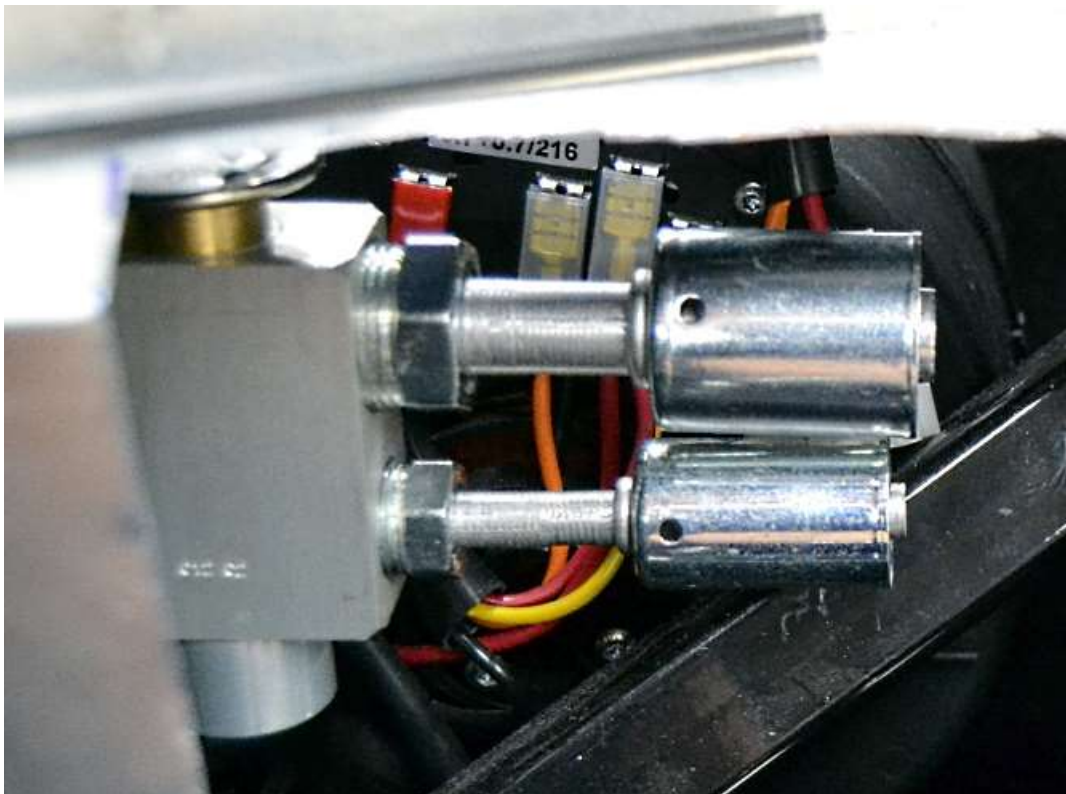

Screw the male #10 fitting into the top of the regulator block on the evaporator.

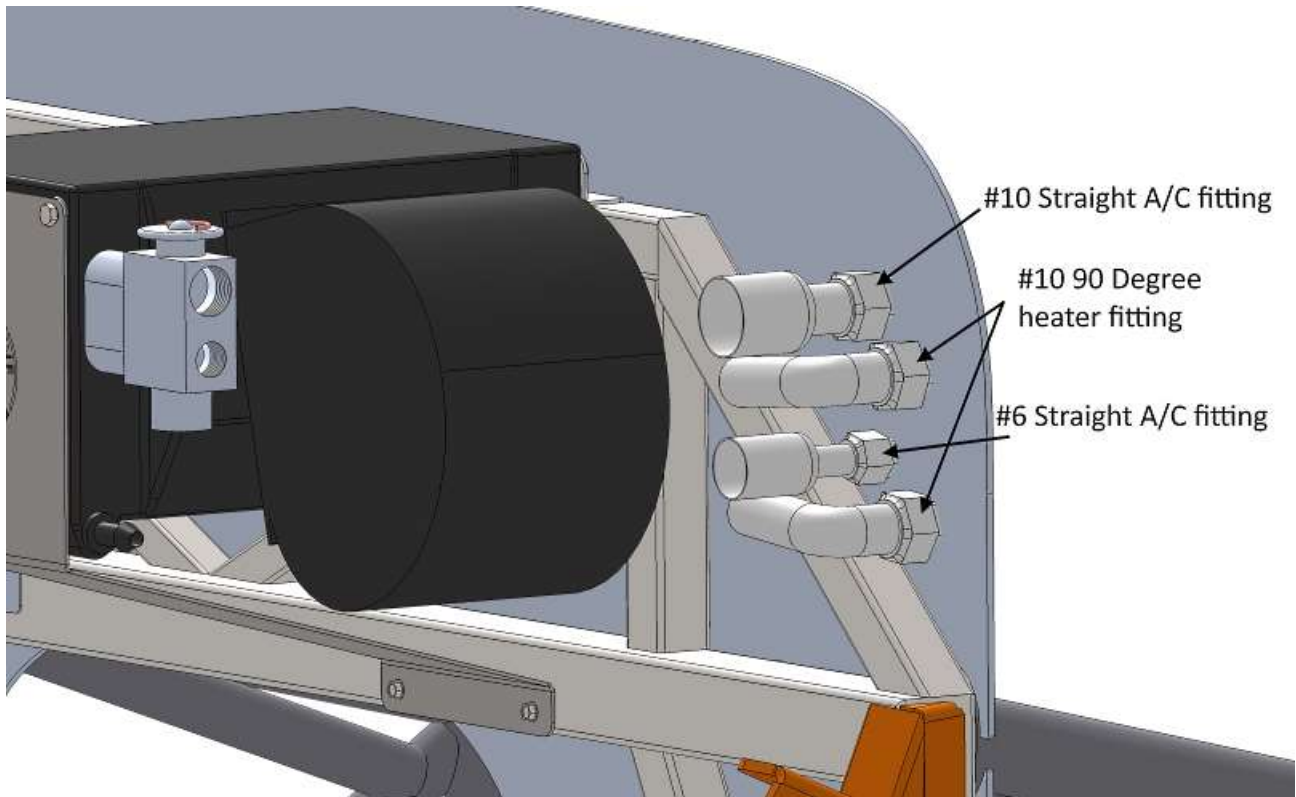

Attach fittings to the inside of the bulkhead adapters as shown.



Try and use the natural curves of the hoses where possible to prevent kinks in the hoses

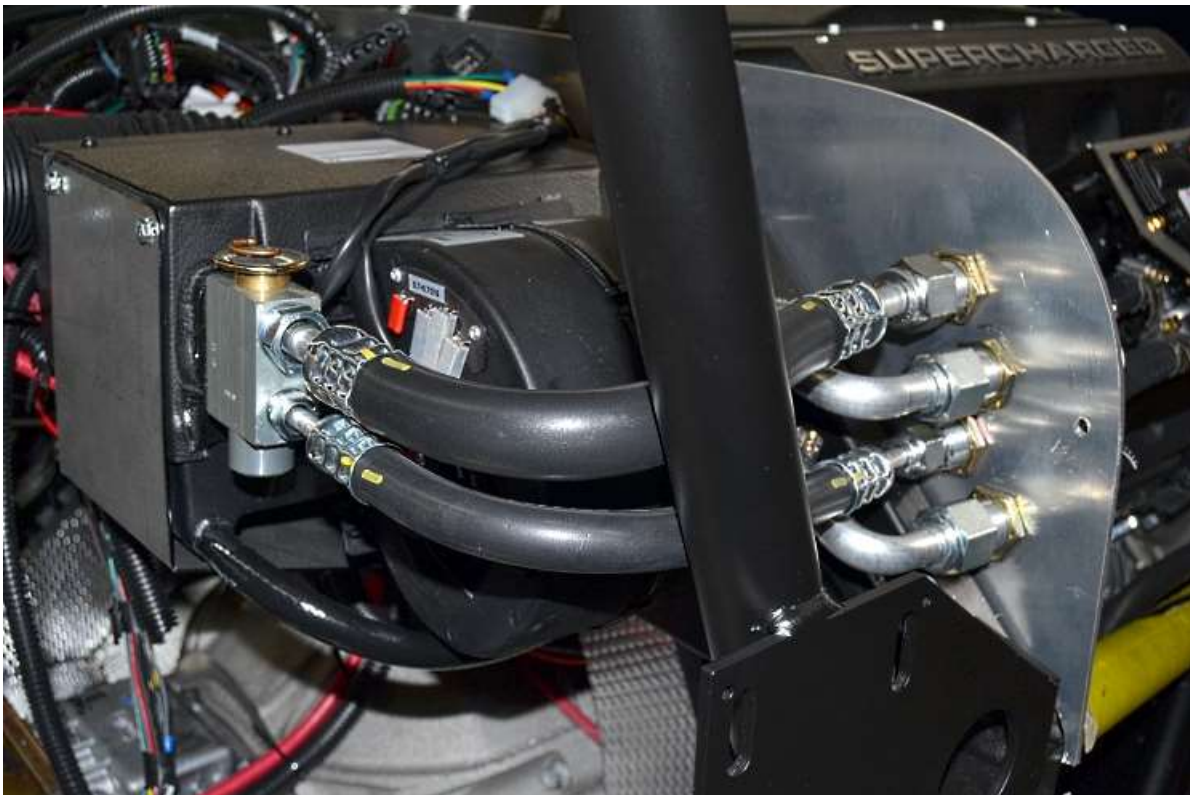

Start with the small A/C fitting on the firewall, push the end of the #6 hose in the firewall fitting and run it over to the evaporator regulator holding it on top of the fitting then mark the hose so that it is even with the end of the large part that will get crimped.



Cut the hose at the location marked using a razor knife.



Assemble the hose and fittings and attach to the evaporator and firewall bulkhead.

Attach the $\frac{5}{8}$ " heater hose to the heater core and the fittings on the firewall using the wider hose clamps and a $\frac{5}{16}$ " socket.

Run the #10 hose the same way as the #6 hose.



Attach the drain hose to both of the drain bars at the bottom of the evaporator using the narrow hose clamps.

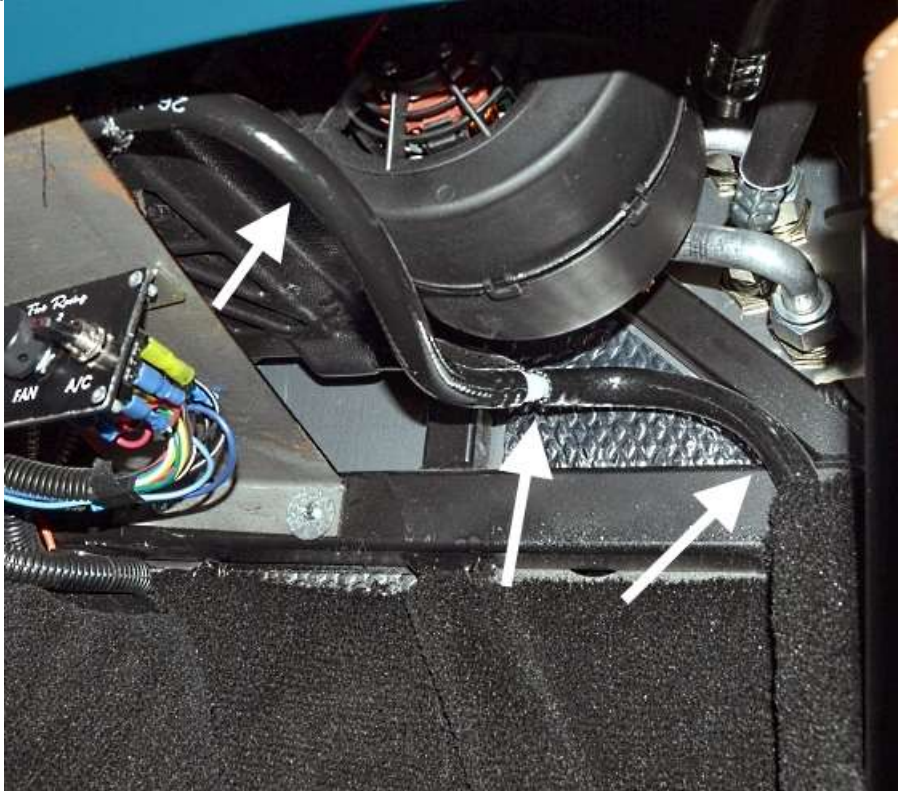
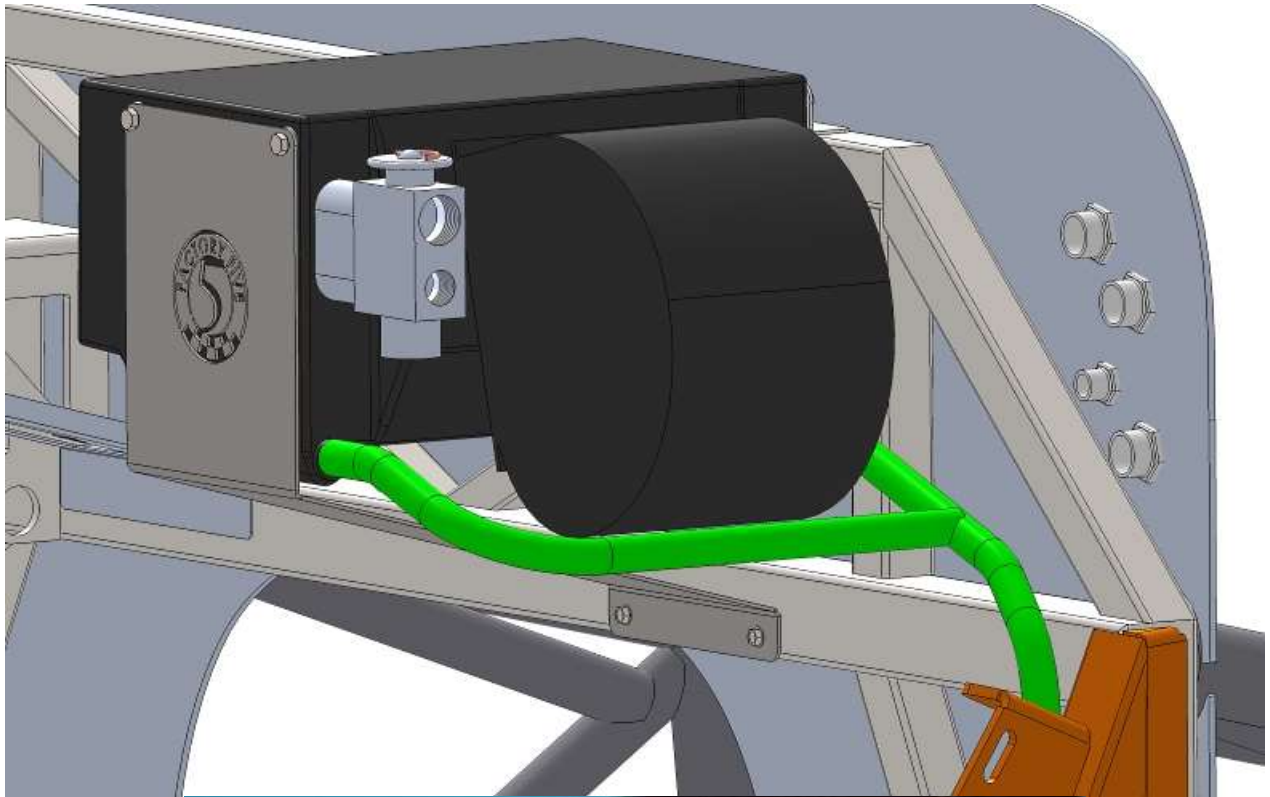

Run the drain hose under the A/C regulator over to the one near the firewall and use the T fitting with hose clamps to connect the lines together.

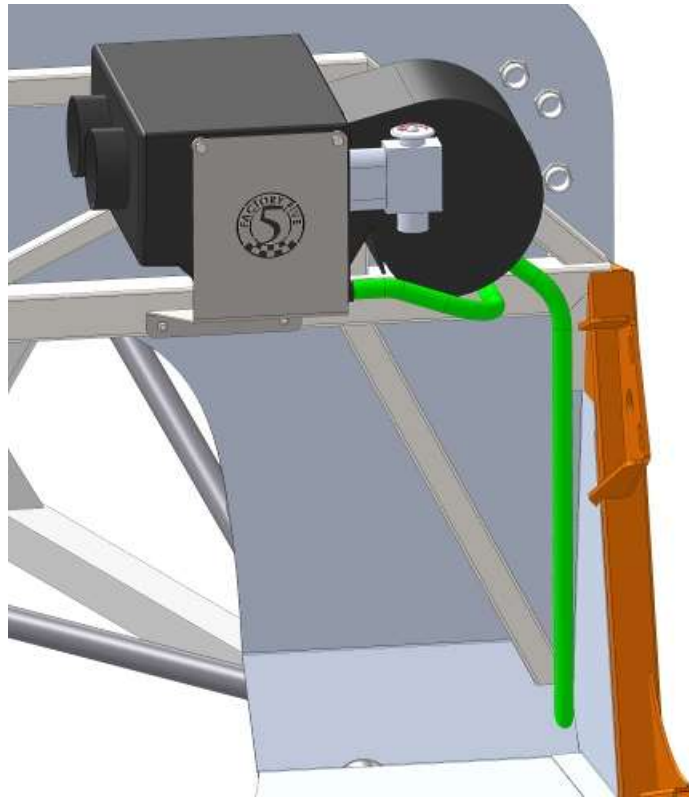

Run the hose along the 1.50" tube to the outside vertical 1.50" tube and down through the floor so the drain will drip on the ground. Drill the $\frac{5}{8}$ " drain hose hole starting with a $\frac{3}{16}$ " hole stepping up to $\frac{5}{8}$ ".



Attach the hose to the frame using $\frac{5}{8}$ " insulated line clips from the kit and the provided $\frac{3}{16}$ " rivets.

If not already in, install the engine.

DRIER

-  A/C Drier components, A/C hoses and Fittings, kit $\frac{3}{16}$ " rivets.
-  $\frac{5}{16}$ " socket, ratchet, $1\frac{1}{16}$ " wrench, clamp, $\frac{3}{16}$ " drill bit, drill, rivet tool



Find a location for the drier, the left picture shows on the firewall, the right shows in front of the compressor.



Locate the drier mounting brackets and large hose clamp.

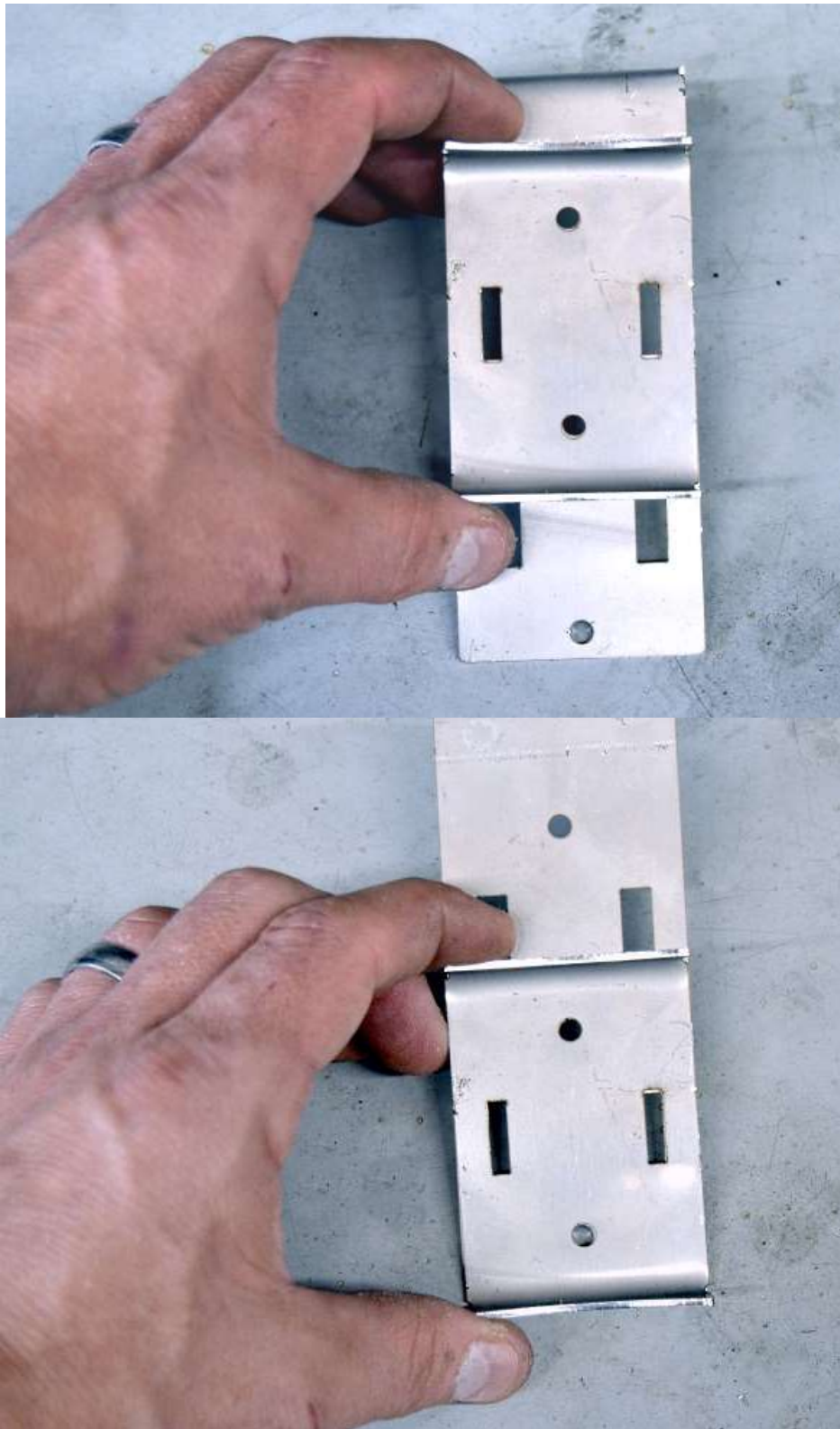

There are two mounting locations for the drier bracket on the frame bracket if the frame bracket is going to be used.



These instructions do not use the tall mounting bracket.



If the frame mounting bracket is going to be used, run the hose clamp through both brackets as shown otherwise just put it through the small bracket.

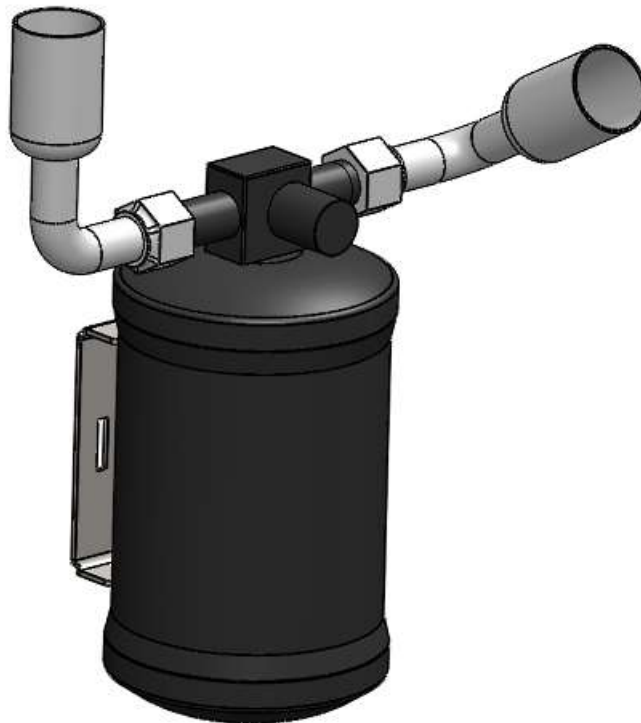

Put a 90° #6 line on the both sides of the drier as shown.



Put some O-ring oil on the Trinary switch O-ring.



Use a 1^{1/16}" wrench to tighten the trinary switch onto the Drier.

Insert the drier into the hose clamp on the mounting bracket and snug the hose clamp up so the Drier just cannot move.



Use masking tape in the approximate area the Drier will be located. Locate and mark the tape where the bracket will mount.

Remove the bracket from the Drier then locate and drill $\frac{3}{16}$ " mounting holes for the Drier bracket.

Rivet the mounting bracket to the frame using the long $\frac{3}{16}$ " rivets.



Reattach the Drier to the bracket using a $\frac{5}{16}$ " socket and ratchet.

HOSES AND FITTINGS – ENGINE BAY



Coyote compressor shown.



A/C hoses and fittings, insulated line clips, $\frac{3}{16}$ " rivets, zip ties.



$\frac{3}{4}$ ", $\frac{7}{8}$ ", $1\frac{1}{8}$ " wrenches, razor knife, silver or white marker, drill, rivet tool, $\frac{3}{16}$ " drill bit.



Try and use the natural curves of the hoses where possible to prevent kinks in the hoses



See hose diagram at end of instructions

Bulkhead

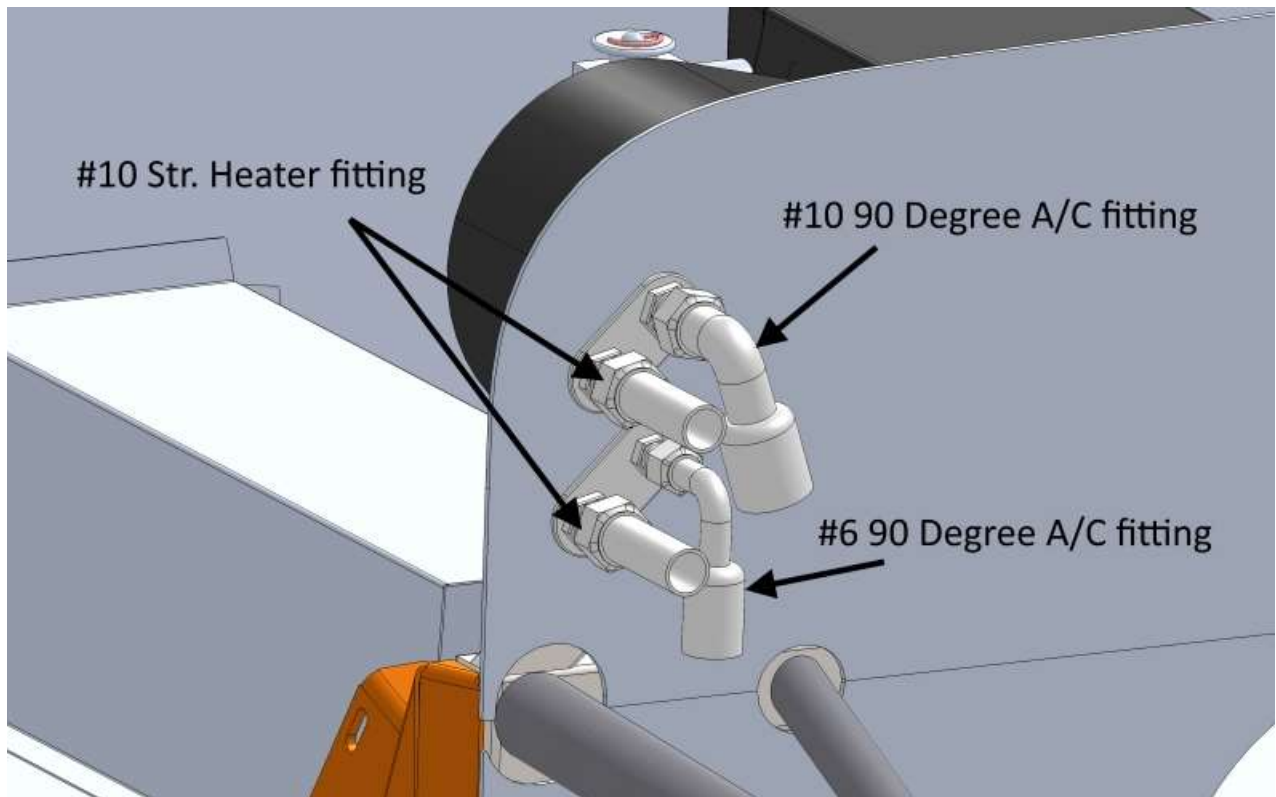

Attach the fittings to the engine bay side of the firewall adapter.



If you have not run fuel lines or mounted a fuel pressure regulator if needed, do this now.

Drier



Run #6 hose from the bulkhead fitting down to the left side of the Drier and cut to length then reassemble.

Compressor #8 hose



Screw the 90° #8 fitting with the valve on the compressor.



Insert the #8 hose into the compressor fitting.

Condenser



Attach the 45° #8 & #6 A/C fittings to the condenser. Run the #8 line from the compressor forward and under the upper control arm to the fitting.



Run the #6 line from the right side of the Drier up along the 1.50" round frame tube then down under the upper control arm to the Condenser fitting.

Compressor #10 hose



Screw the 135° #10 fitting with the valve onto the compressor then run the #10 hose from the compressor down and back under the engine mount.



From under the engine mount run the hose back to the firewall and up behind the Drier to the bulkhead fitting.

HEATER CONTROL VALVE

- ✂ ¼" socket, ratchet
- 🔧 Heater control components



Remove the three screws holding the black bracket to the plastic box using a ¼" socket.



Put the control valve bracket over the plastic box and reattach the screws through the stainless bracket, black box and into the threaded black bracket.

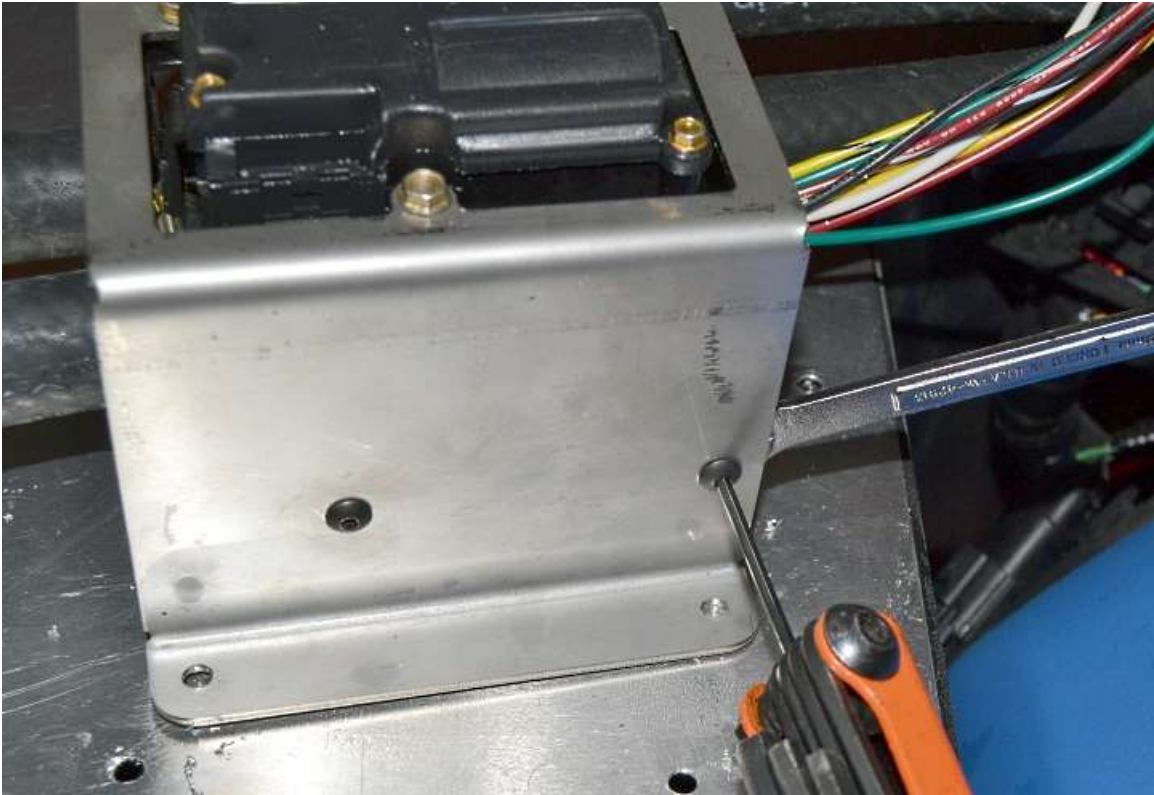

Attach the controller to the inside of the front side of the control valve bracket.



Position the control valve on the engine or the firewall between the bulkhead fitting and the engine heater fittings.



Run and cut to length $\frac{5}{8}$ " heater hose from the control valve to the bulkhead fittings. The hoses can go on either fitting as long as they are on the same side of the valve.



The next steps will depend on the engine being used. The engine heater hose outlet and inlet need to get attached to the control valve in the correct locations. For this install we used a Coyote engine.



On the left side of the engine near the throttle body remove the heater return connector if already installed.



On the right side of the throttle body remove the heater send connector if already installed.



If the Coyote engine was already running and driving, make sure to take the restrictor out of the hose if reusing a hose.



Connect $\frac{5}{8}$ " heater hose and a hose clamp to one of the fittings.



Reattach the connector to the send (right side) fitting on the engine.





Slide a hose clamp on the end of the hose and run the heater hose to the return (arrow pointed out of valve) connection on the heater control valve.



Reattach the connector to the return (left side) fitting on the engine.

Slide a hose clamp on the end of the hose and connect the hose to the send (arrow pointed into valve) connection on the control valve.

Final hose installation

-  $\frac{5}{8}$ " , $\frac{3}{4}$ " , $\frac{7}{8}$ " , $1\frac{1}{16}$ " wrenches, adjustable wrench, bead lock tool
-  A/C hose fitting crimping tool, razor knife, silver/white marker, adjustable wrench, $\frac{5}{8}$ " , $\frac{3}{4}$ " , $\frac{7}{8}$ " , $1\frac{1}{16}$ " wrenches
-  It is highly recommended that all of the fittings get crimped by an A/C shop that makes refrigerant lines with a hose crimping machine instead of buying your own crimping tool if at all possible. This will reduce the possibilities of any leaks because of the crimps.
-  Use masking tape on each hose to mark the location of each hose.



If you must buy a tool use one like Mastercool 71550.

These instructions were written using the Mastercool tool. We had one #8 fitting we had to re-crimp due to a leak.



Crimp the hoses in the fittings using a Beadlock crimp tool making sure to push the hoses all the way into the fitting and line up the alignment dots made earlier on the hose and fitting.



If manually crimping the hoses like above, make sure that the tool is tightened per the instructions.



Mark the orientation and end location of each fitting as shown on both the hose and the fitting.

INSIDE

Remove all of the hoses inside the cockpit.



Crimp each fitting onto the end of the hose.



Starting with the #6 hose, push the O-rings onto the end of the fittings.



Lubricate the O-ring with the oil included.

Screw on fitting onto the bulkhead fitting and the Evaporator by hand making sure the hose is not twisted. Hold the expansion valve with an adjustable wrench and tighten the fitting using a $\frac{5}{8}$ " wrench. Tighten the bulkhead fitting using a $\frac{3}{4}$ " wrench.

Put an O-ring and oil onto the two heater hose bulkhead fittings.

Push the lower heater hose onto the lower Evaporator barb and tighten the hose clamp with a $\frac{5}{16}$ " socket. Attach the lower heater hose to the lower bulkhead fitting by hand then tighten with a $1\frac{1}{16}$ " wrench or adjustable wrench.

Repeat for the upper heater hose.



Finish with the #10 hose by attaching it to the bulkhead fitting and the Evaporator by hand making sure the hose is not crimped.

Hold the expansion valve with an adjustable wrench and tighten the fitting using a $\frac{7}{8}$ " wrench.

Tighten the bulkhead fitting using a $1\frac{1}{16}$ " wrench.

ENGINE BAY A/C



Remove, crimp and install one hose at a time.



Do the two bulkhead A/C lines before doing the heater hoses.



Mark the orientation and end location of each fitting as shown on both the hose and the fitting.



Crimp each fitting onto the end of the hose.





Push the O-rings onto the ends of the fittings and lubricate the O-rings with the oil included.

Screw on fittings on by hand making sure the hose is not crimped.
Tighten the fitting using a wrench.

Air ducts

DASH

-  A/C duct components
-  Razor knife, wire cutter, tape measure, drill, 2.50" hole saw.





Cut a 16" piece of the 2.50" air hose with a razor knife.



Use wire cutters to cut the hard wire.



Push the hose on the right evaporator hose connector.



Use a cable tie around the hose and connector so that the duct stays in place.



Push the other end of the hose into one of the Y connectors and zip tie the hose on.



Push the end of the long 2.50" hose onto one of the other Y connections and zip tie the end to the Y.



Decide where the dash vents will get mounted, here we show them in the dash. They could also get mounted under the dash if you do not want them to be seen.

Run the long 2.50" hose over to the left side of the frame roughly where you will mount the vent and cut the hose.



Rivet a small insulated clip from the kit to the firewall tubes then use a zip tie to hold the hose in place.



Put the remaining hose on the last Y connection and zip tie the hose on.

Pull the hose to the right side of the dash and cut the hose.
Drill 2.50" holes in the dash where the dash vents will mount.



Put the dash vent in the hole drilled from the front.



On the back side of the dash, start with one aluminum spacer on the vent.



Screw the vent hose connection onto the vent. If necessary, add an additional aluminum ring to build up the thickness.



Push the vent hose onto the dash vent and zip tie.

DEFROSTER

- ✂ Long straight edge, marker, square, Drill, $\frac{5}{32}$ " drill bit, silicone gun, Philips head screwdriver, ratchet, $\frac{5}{16}$ " deep socket.
- 👉 The vents and trim piece will look different than some of the pieces in the picture, the parts have been changed.
- 👉 If doing an alternative gauge layout to the layout shown on the dash template, make sure to locate the vents so that there is no interference with the back of the gauges.



Use a long straight edge touching the edges of the dash and a square to find the center of the dash.

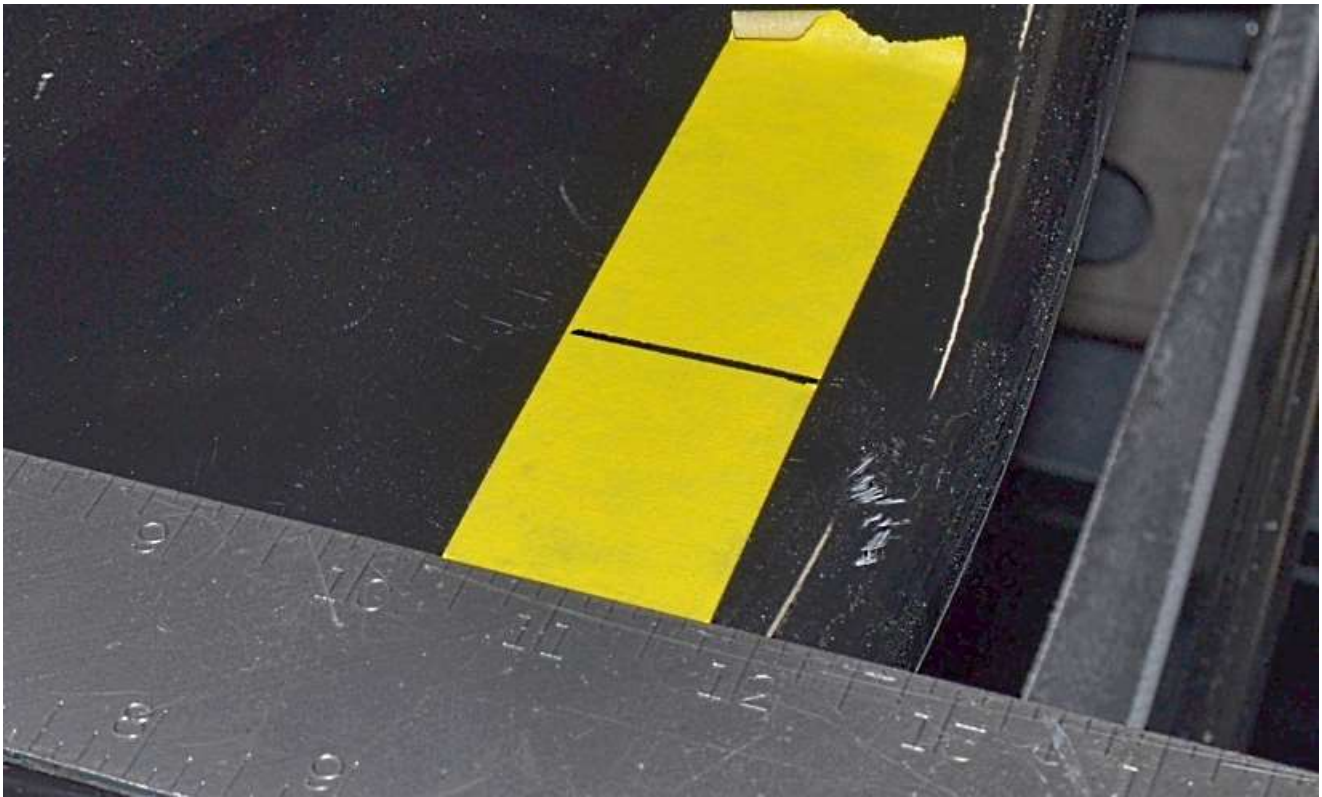

Use a marker and masking tape to mark the top of the dash.



On a hot rod, in front of the driver and passenger measure from the edge of the dash towards the windshield location 3" and put a dot on the top of the dash. On the truck this measurement should be 5.50".

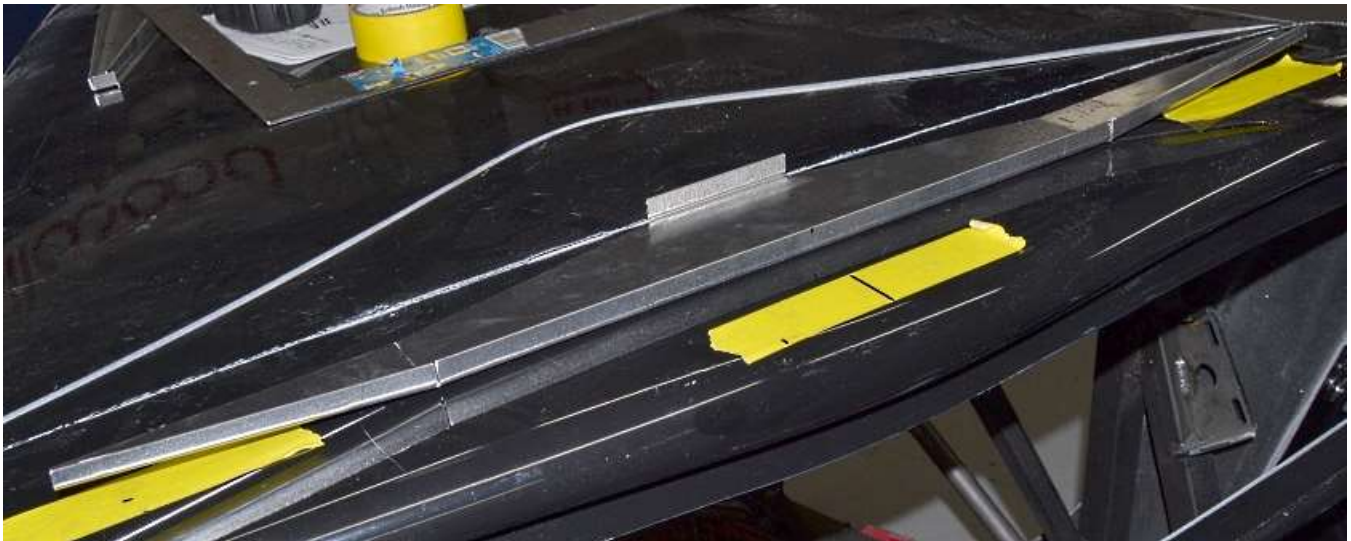

Use the top of the defroster duct so the dots are in the defroster openings.

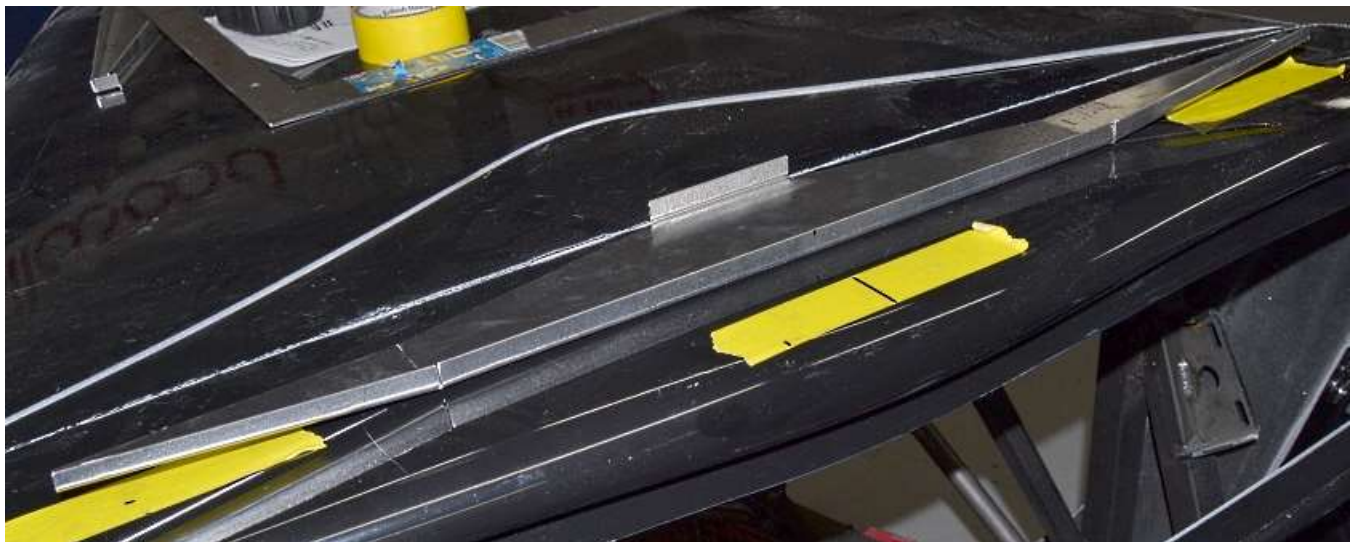

Line the center of the defroster duct (laser cut mark) up with the center mark on the dash and center the defroster vent line in the vent slot on the duct.



Mark the top of the dash with the small mounting holes and large rectangular defroster vent locations.

Silicone the inside corners of the lower defroster duct.

ITEM NO.	PART NUMBER	DESCRIPTION	QTY.
1	34688	DUCT BOTTOM	1
2	60609	2.50" HOSE ADAPTER WITH FLANGE	1
3	34687	DUCT TOP	1
4	14831	DEFROSTER VENT	2
5	25799	3/16" SHORT RIVET	4
6	12780	#6 x 1/2" TRUSS HEAD TAPPING SCREW	4

REV.	DESCRIPTION	DATE	APPROVED
A	INITIAL RELEASE	8/30/18	

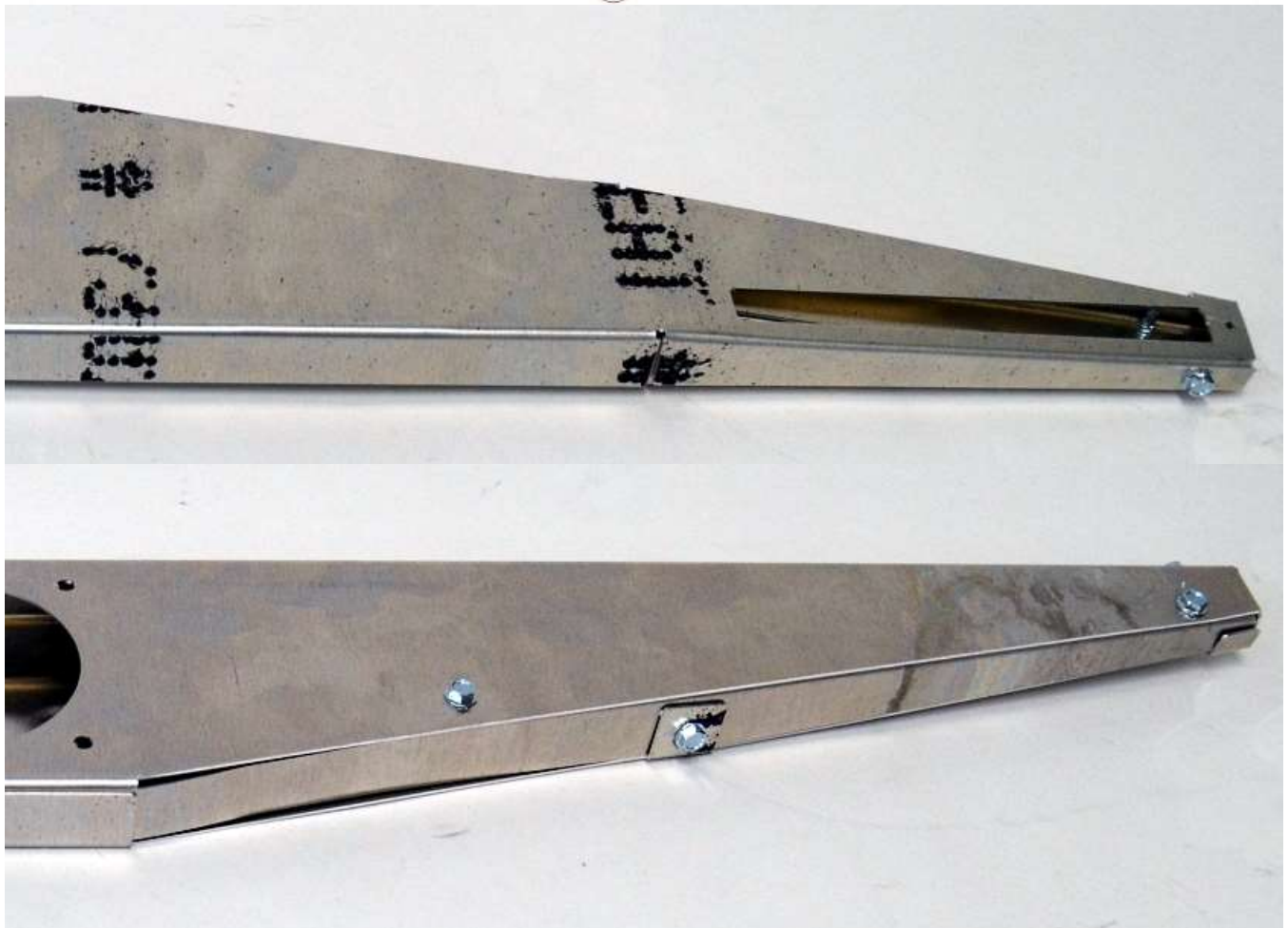
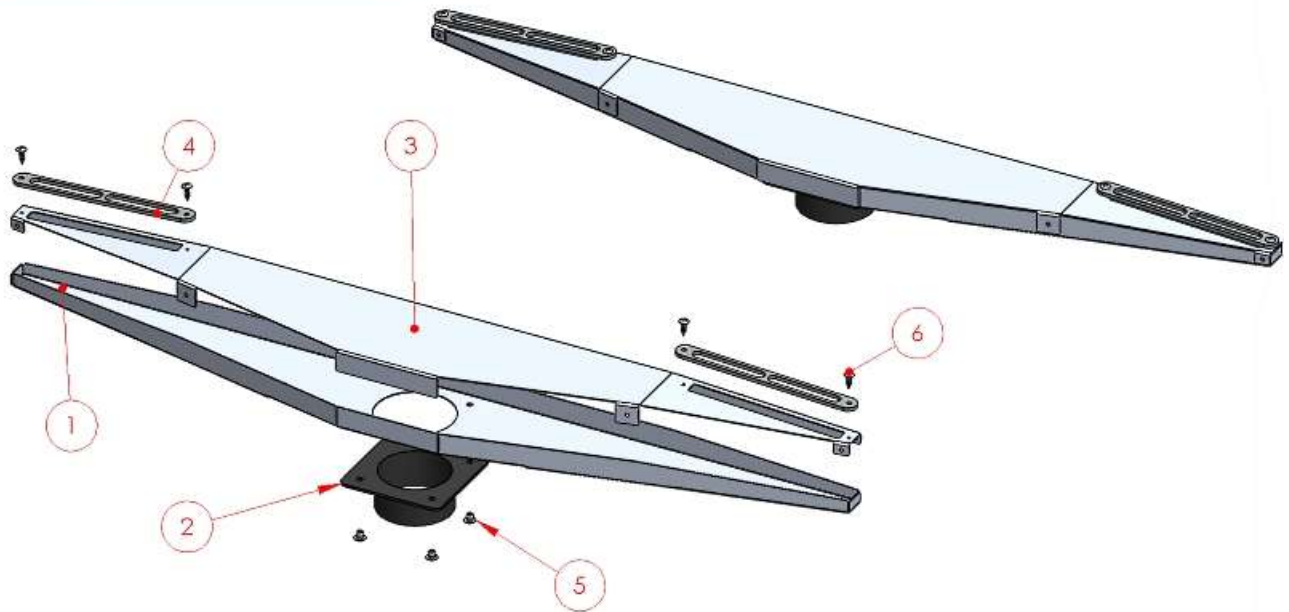

Silicone and assemble the Defroster vent duct using kit aluminum self tapping screws then use the included 1/8" rivets with the top duct going on the outside of the lower duct flanges.

Silicone and rivet the 2.50" hose adapter flange to the bottom of the defroster duct.



Drill the two $\frac{5}{32}$ " screw holes and $\frac{7}{16}$ " holes at each end of the slot then cut the marked center area out using a jig saw or hacksaw blade.

Screw the #6 truss head screws into the duct so that they make threads in the duct holes.



If the vent is tight against the gauges or other parts, on one long side of the vent, sand some of the mounting surface off at an angle so that the duct can angle away from the part.



The following steps should be done after the body is back from the paint shop before the body is put on the frame.



If the slots are cut after the body is back from paint, use a marker on the edge of the fiberglass cut out so that it disappears behind the vent trim.



Place the vent trim on the body (Hot Rod) or dash (Truck) with the mounting screws.

Test fit the duct and orient the duct to give the most clearance where needed with the gauges or firewall. Run a bead of silicone around the vent duct inside where the mount holes are.

Push the duct against the underside of the body on the mounting screws making sure that the duct is oriented correctly if it was angled or modified.

Screw-in the duct/vent trim screws so the duct tightens against the body and seal.



When attaching the body, make sure that the hoses do not get crushed when putting the body on.

Attach the vent hoses to the duct and zip tie.

Wiring



Wire crimper, masking tape, small zip ties, wire cutters, wire crimpers, pen



Heater control components, A/C electrical components



See wiring diagram at end of instructions

TRINARY SWITCH

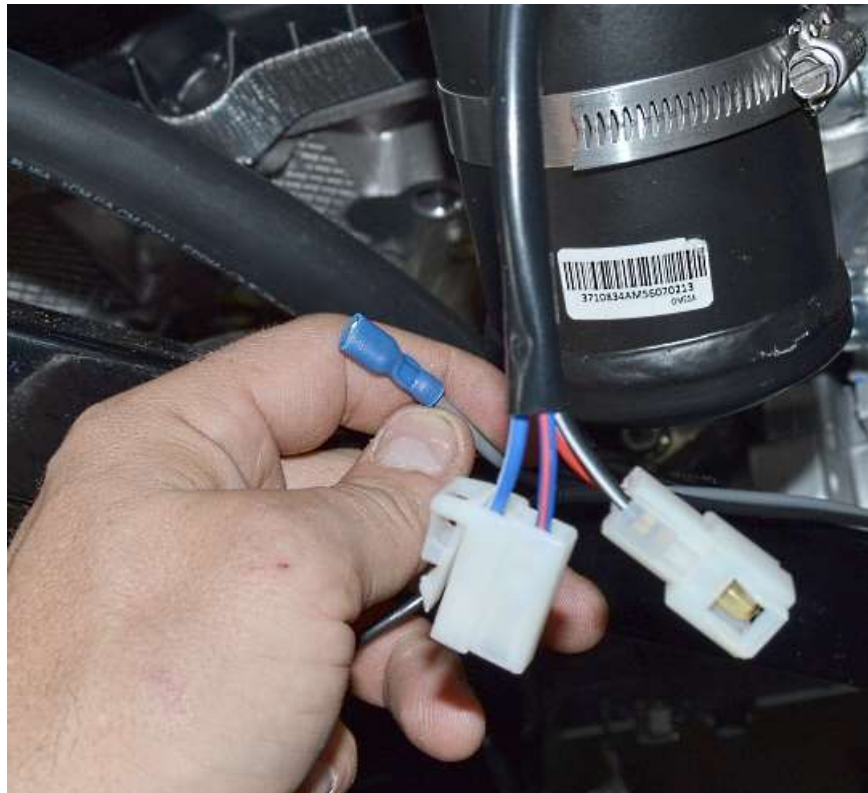

Run the gray compressor wire up to the trinary switch attached to the drier and attach a 1/4" female connector to the end.



Attach the gray wire to the red/white wire.



Starting at the compressor, put the gray and black wires in the conduit.

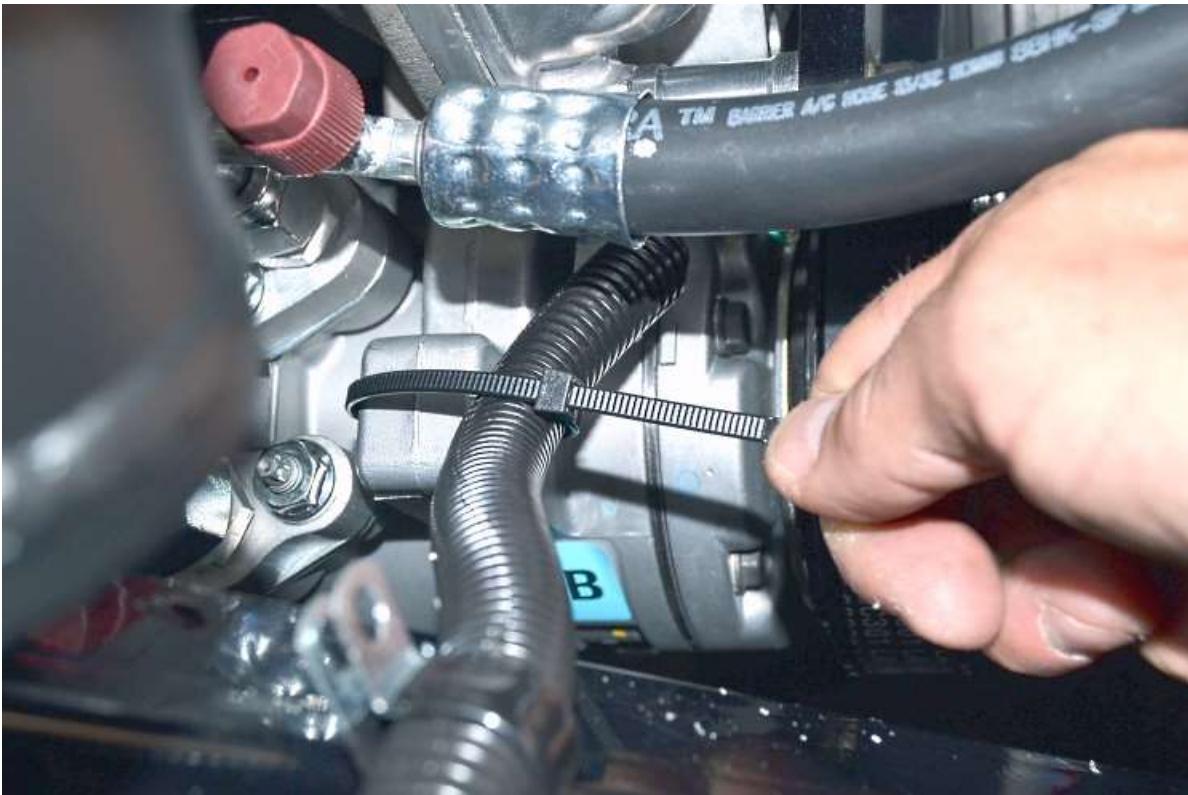

Zip tie the conduit to the compressor so that it will not swing into the belt.



Attach another 1/4" female connector to the remaining gray wire and push the connector onto the black/white wire connector with the other gray wire already in.

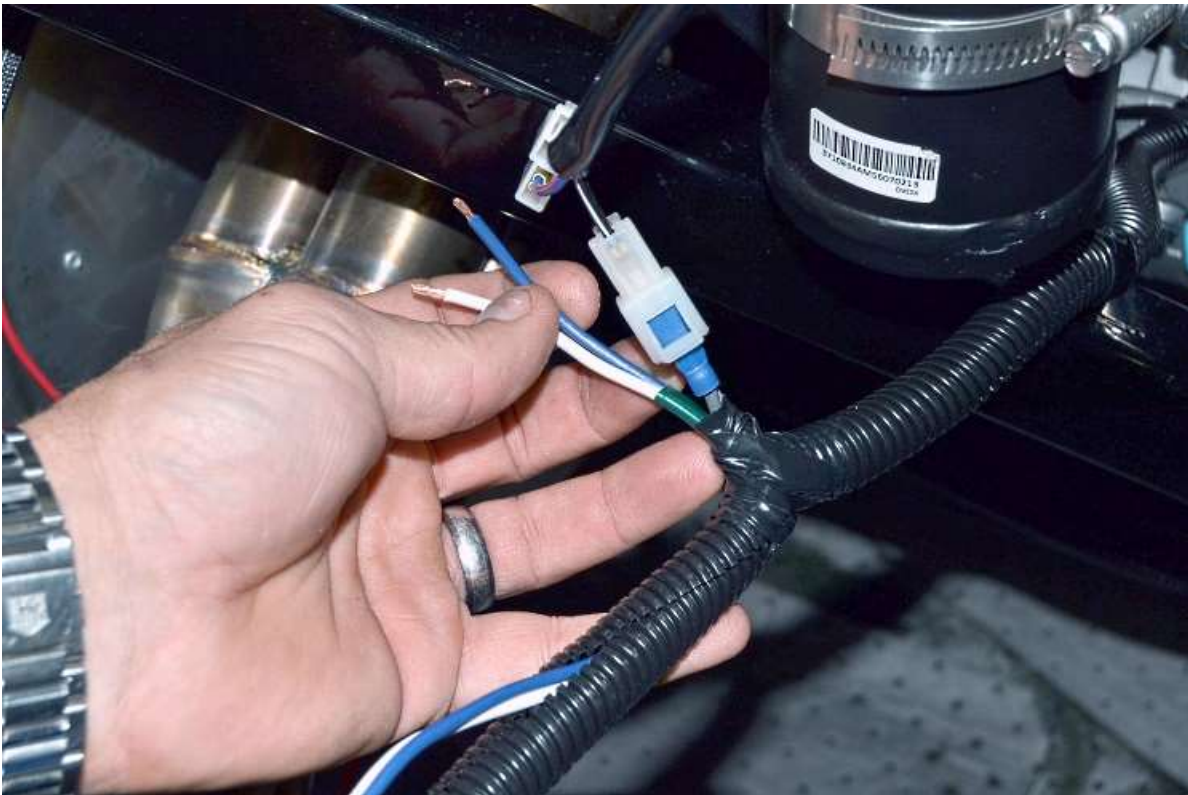

Put the blue and white wires included in the conduit leaving a short section out at the Drier.



Attach 1/4" **male** connectors to the white and blue wire.



Attach the white to the blue/white wire connector and the blue wire to the blue/red wire connector.

Push the gray, white and blue wires into the conduit and run the conduit to the heater control valve.

HEATER CONTROL VALVE

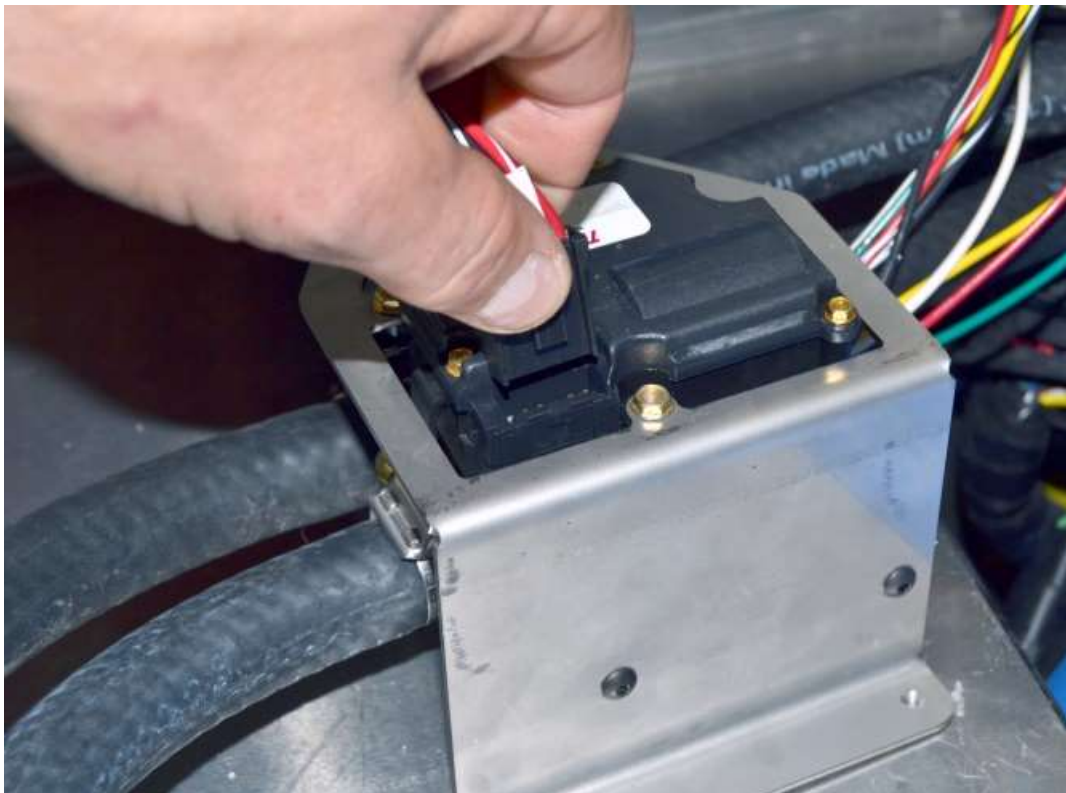

Run the wires from the heater control valve controller out and plug the connector into the front of the heater control valve.

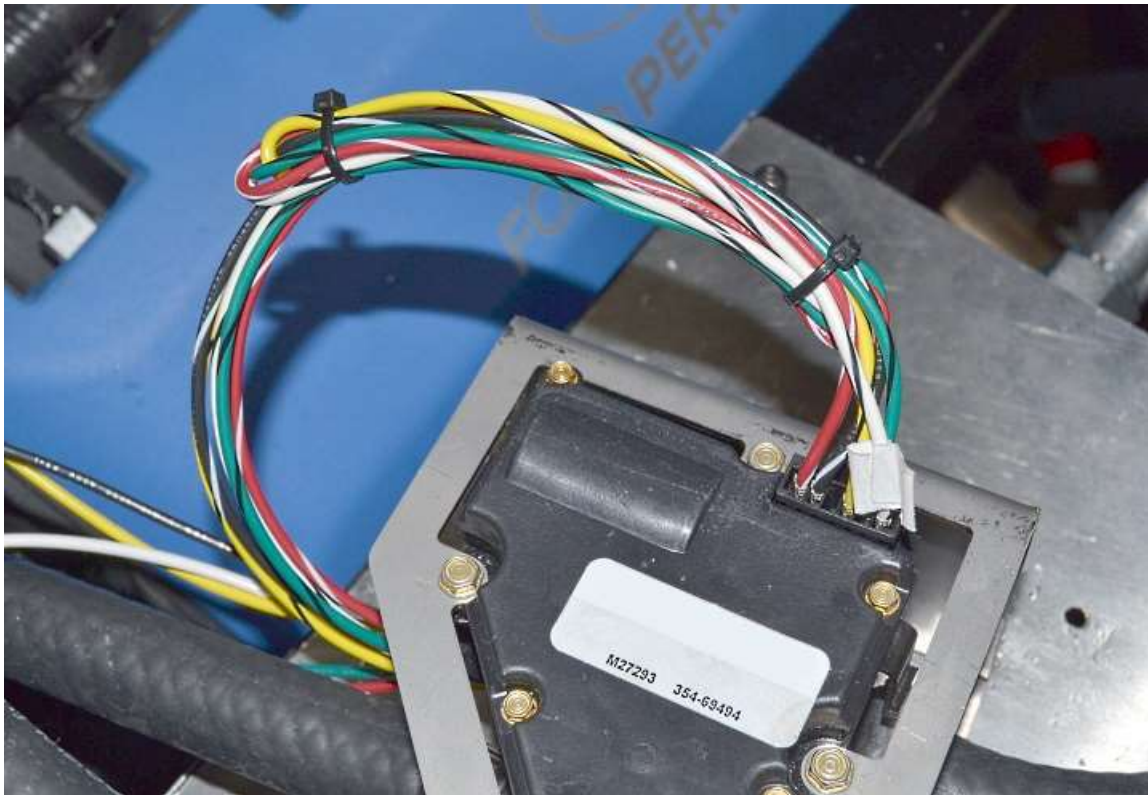

Zip tie the wires going to the plug together to shorten them up.



Use a short piece of conduit from the kit to cover the plug wires.

Connect the green, white and yellow wires from the controller to the 4-conductor wire corresponding wires.

Connect the black ground from the compressor and the black controller ground to the brown wire.

Connect the red controller wire to the red wire.
Run the wires in the conduit to the transmission tunnel.
Pass the wires into the cockpit.



Locate a frame ground in the dash area, cut the white wire to length and attach a ring terminal to ground it.

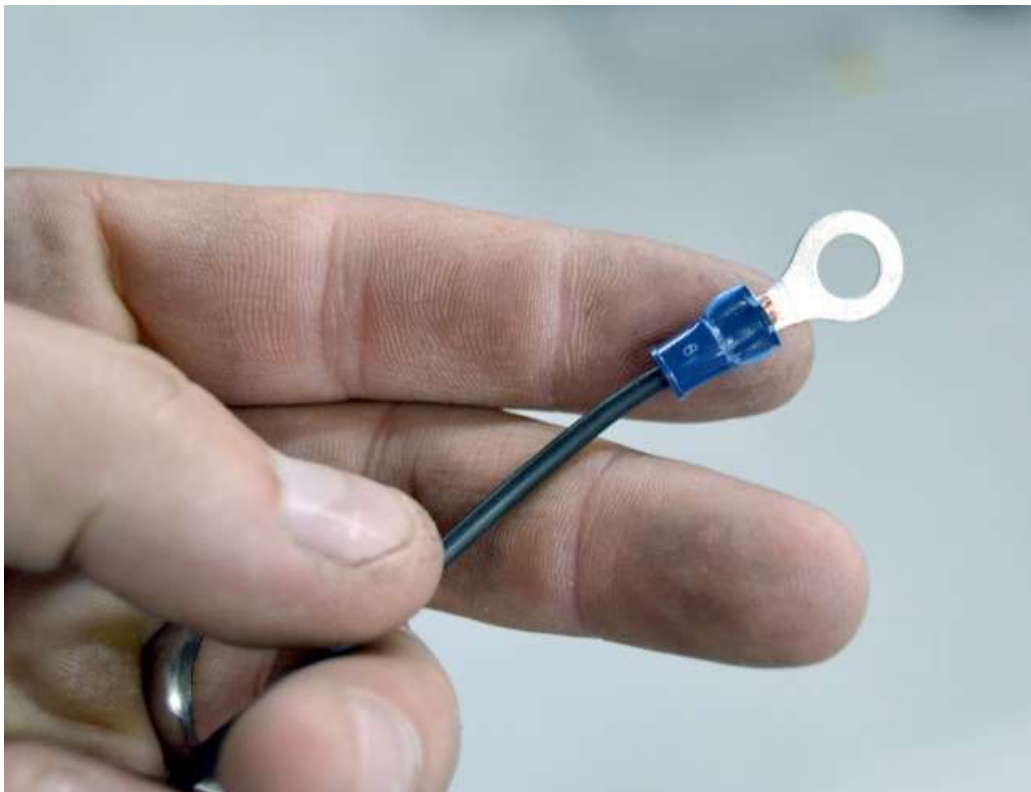

Place a ring terminal on the end of a black piece of wire.



Ground the two ring terminals on a frame ground then run the wire back to the “Drier” wires at the dash center location.

Cut the remaining “Drier” wires except for the blue wire 12” from the grommet.

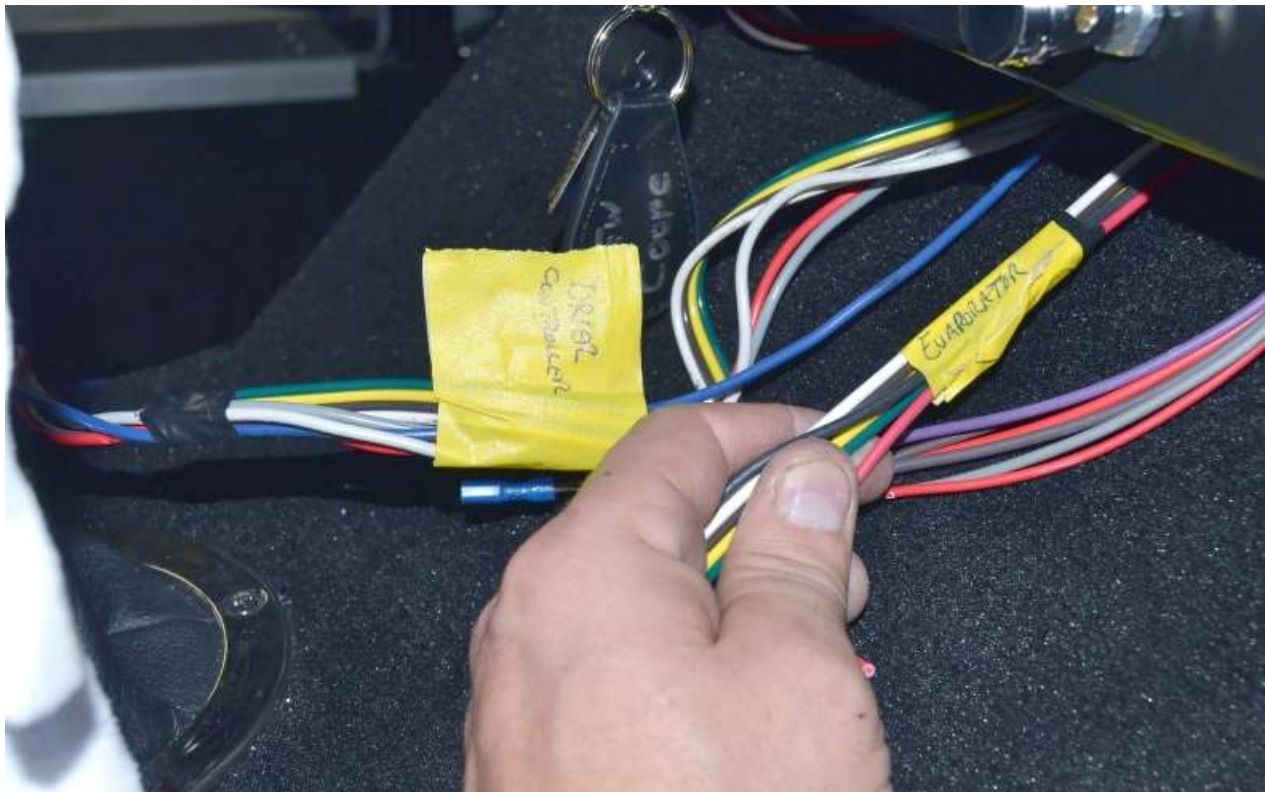

Wrap the wires 6” from the end with masking tape and write “Drier/Controller” on it.

FAN



The following install uses the Factory Five chassis harness wiring and Coyote engine controls controlling the fan. Using the Fan thermostat switch is the same.

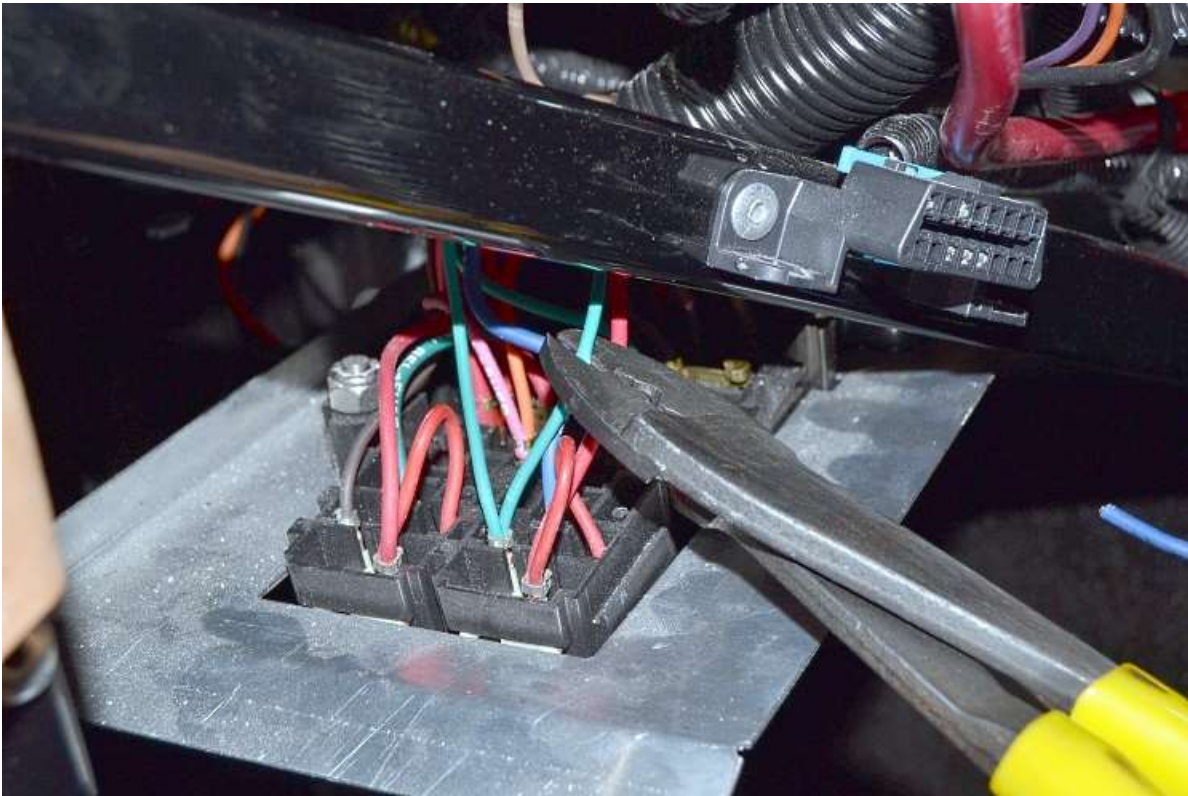

On the back of the fuse panel, cut one of the green thermostat switch wires on the fan relay long enough so that it can be used still.

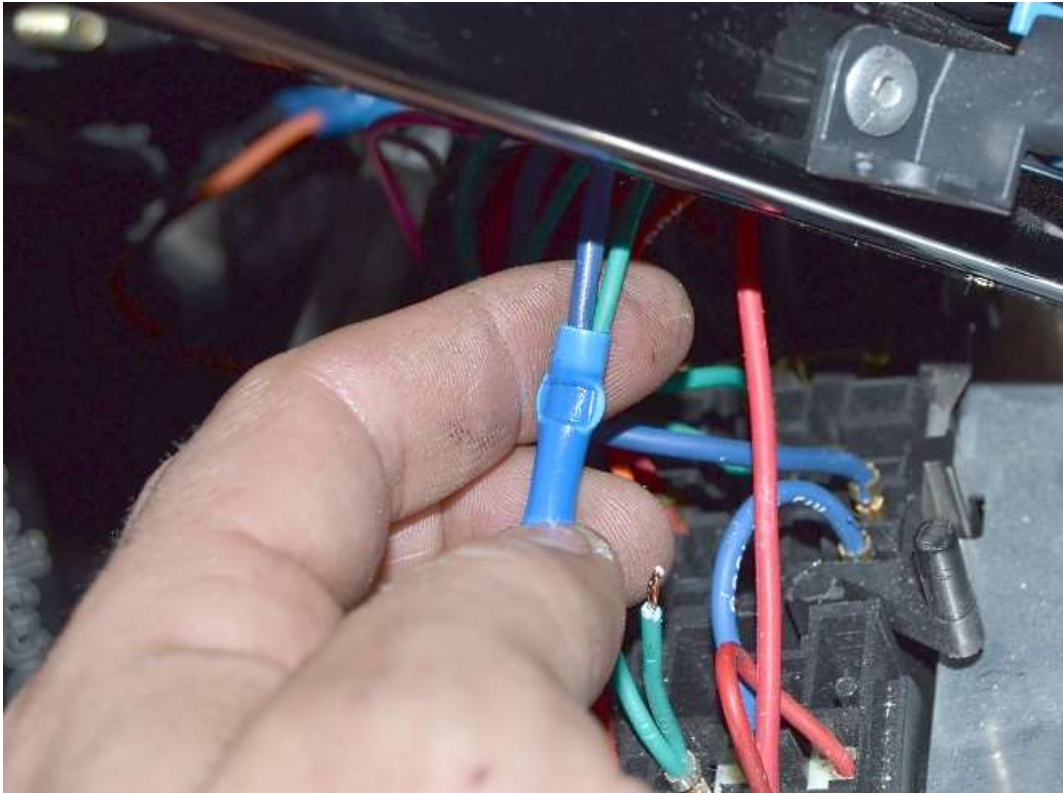

Connect the blue “Drier” wire and green thermo wire just cut in the same end of a blue butt connector.

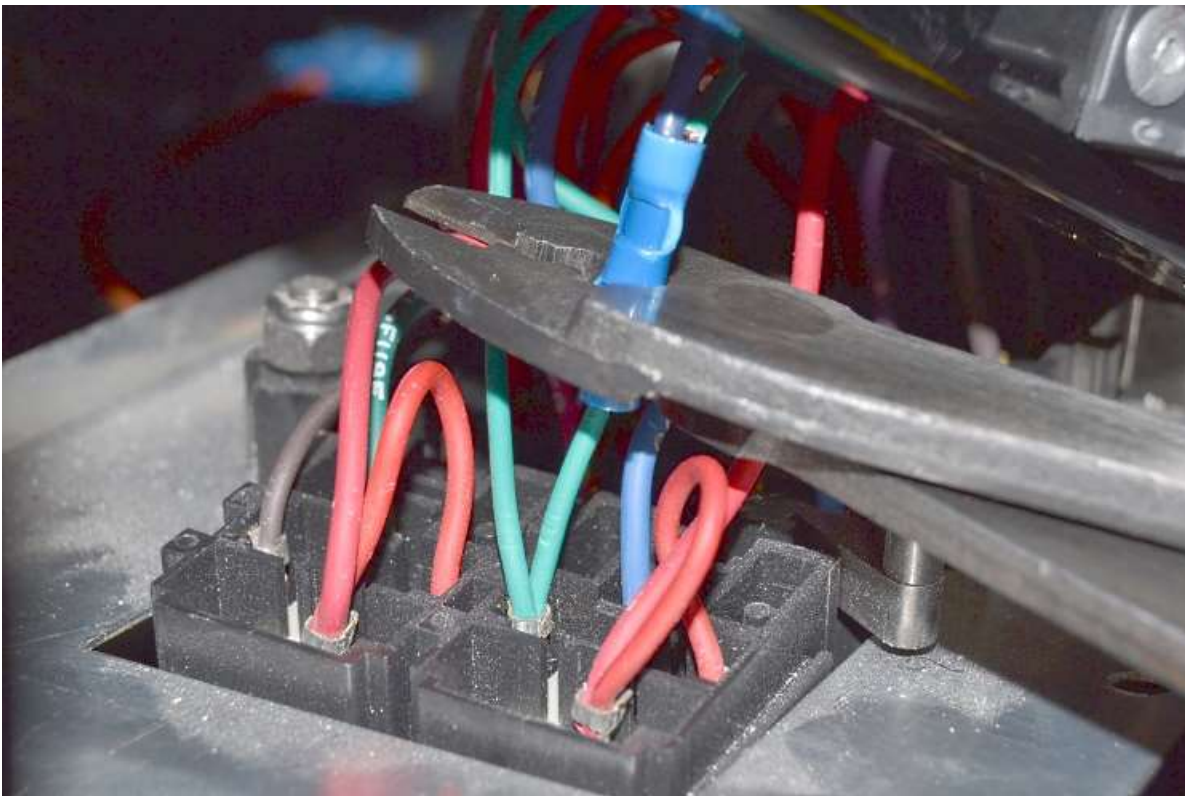

Reconnect the other end of the butt connector to the green wire stub on the relay.

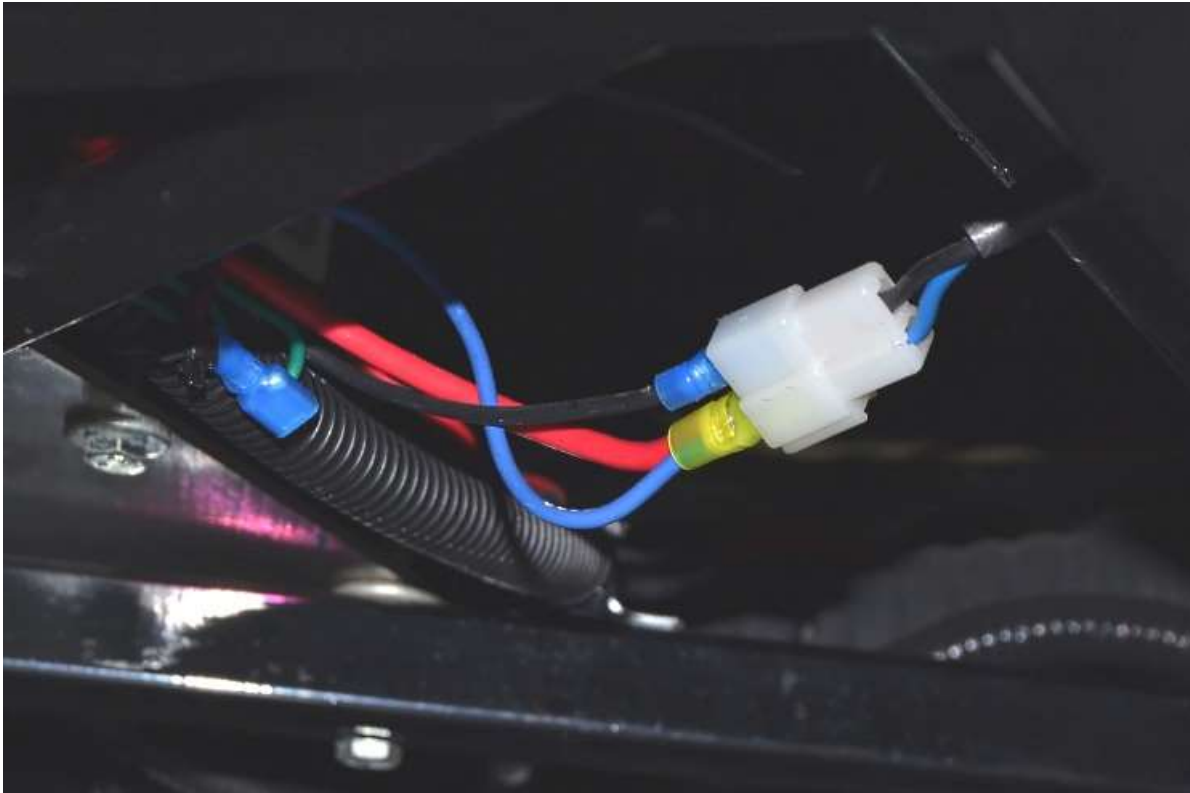

At the front of the car at the fan wiring location, if using an engine-controlled fan, use the included yellow ¼" female connector to connect both the chassis harness blue fan wire and the engine control fan wire and attach to the fan power. If not engine controlled, just make sure the blue fan wire is connected.

EVAPORATOR MOTOR

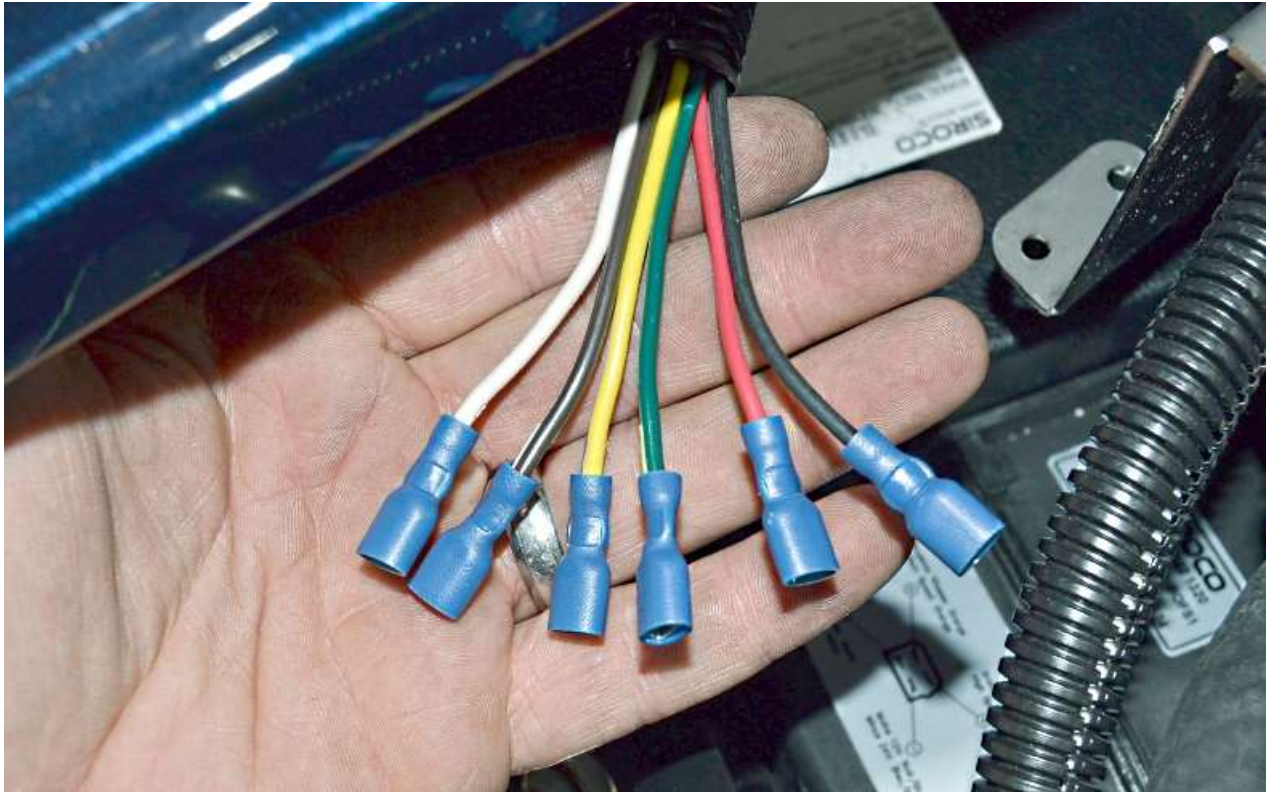

Put ¼" female terminal connectors on the end of the remaining 4-conductor wire along with the red and black wire.

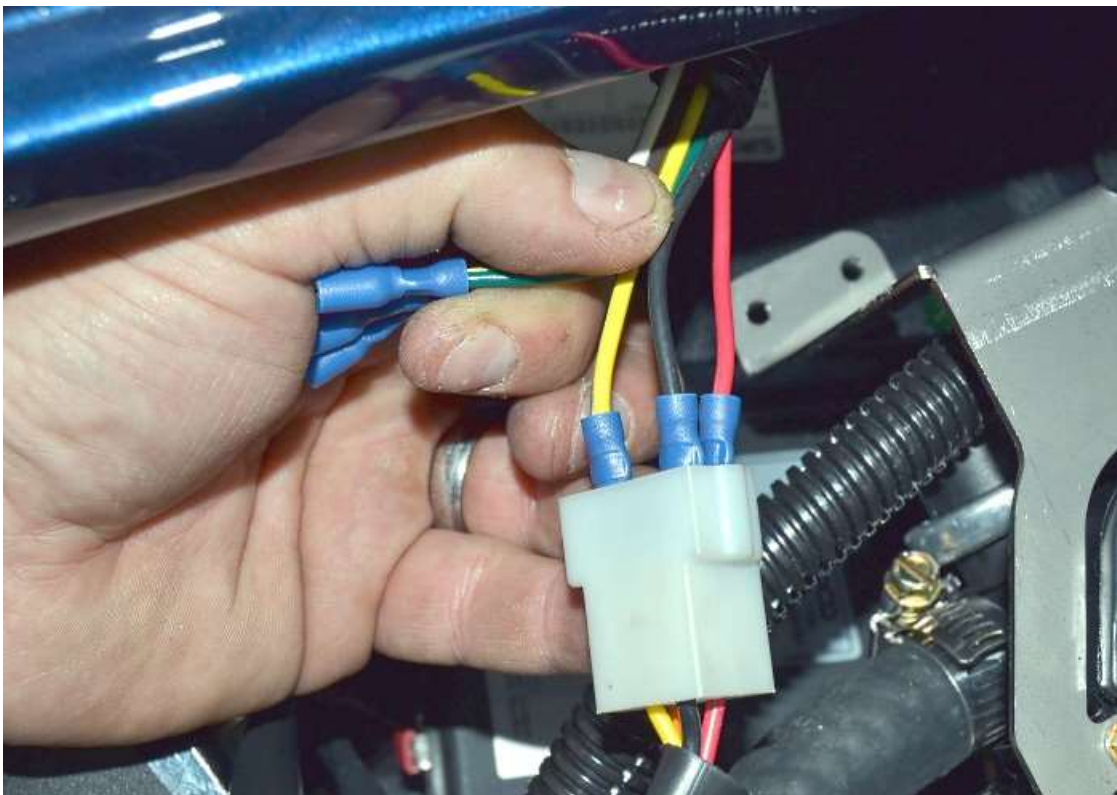

Locate the motor plug on the evaporator and connect the red, black and yellow wires to the corresponding colors in the plug; use the green wire to connect to the motor orange wire.

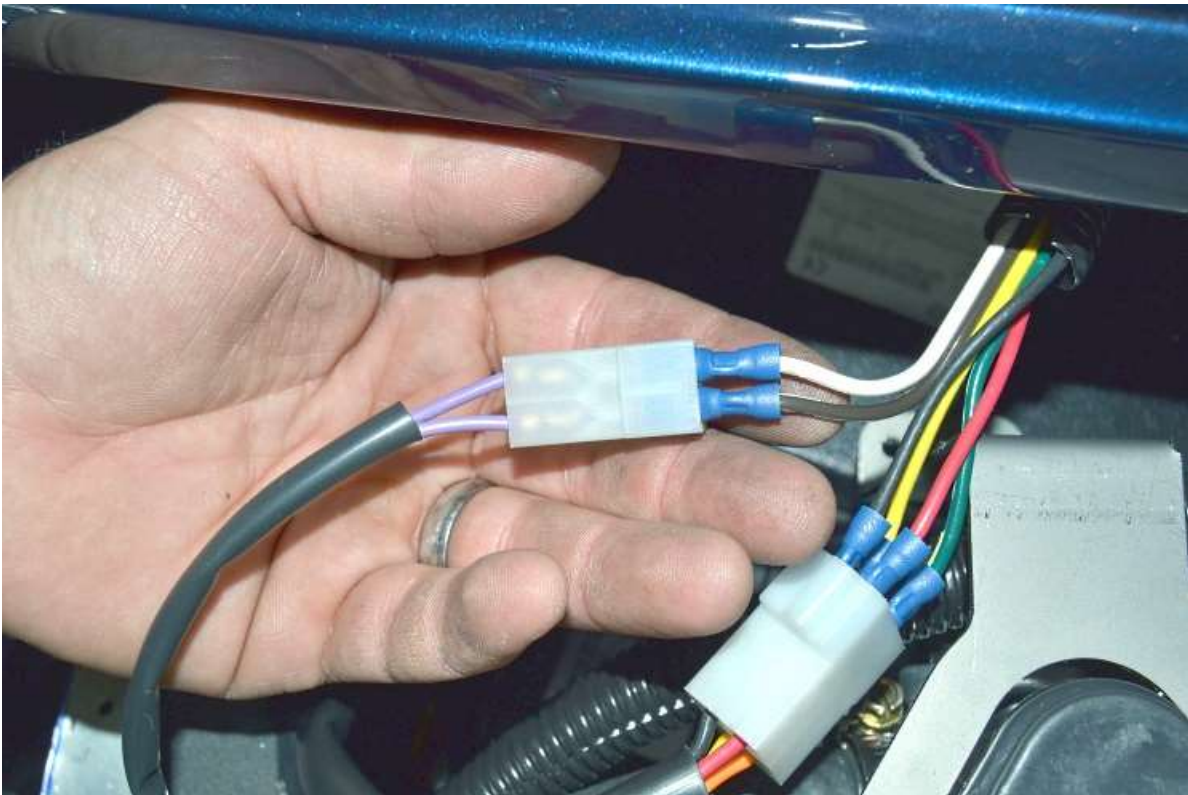

Locate the thermostat plug coming off the evaporator and plug the white and brown wires into these. It doesn't matter which color goes where.



Wrap the wires in conduit and run them to the center of the dash location where the Drier/Controller wires are located.

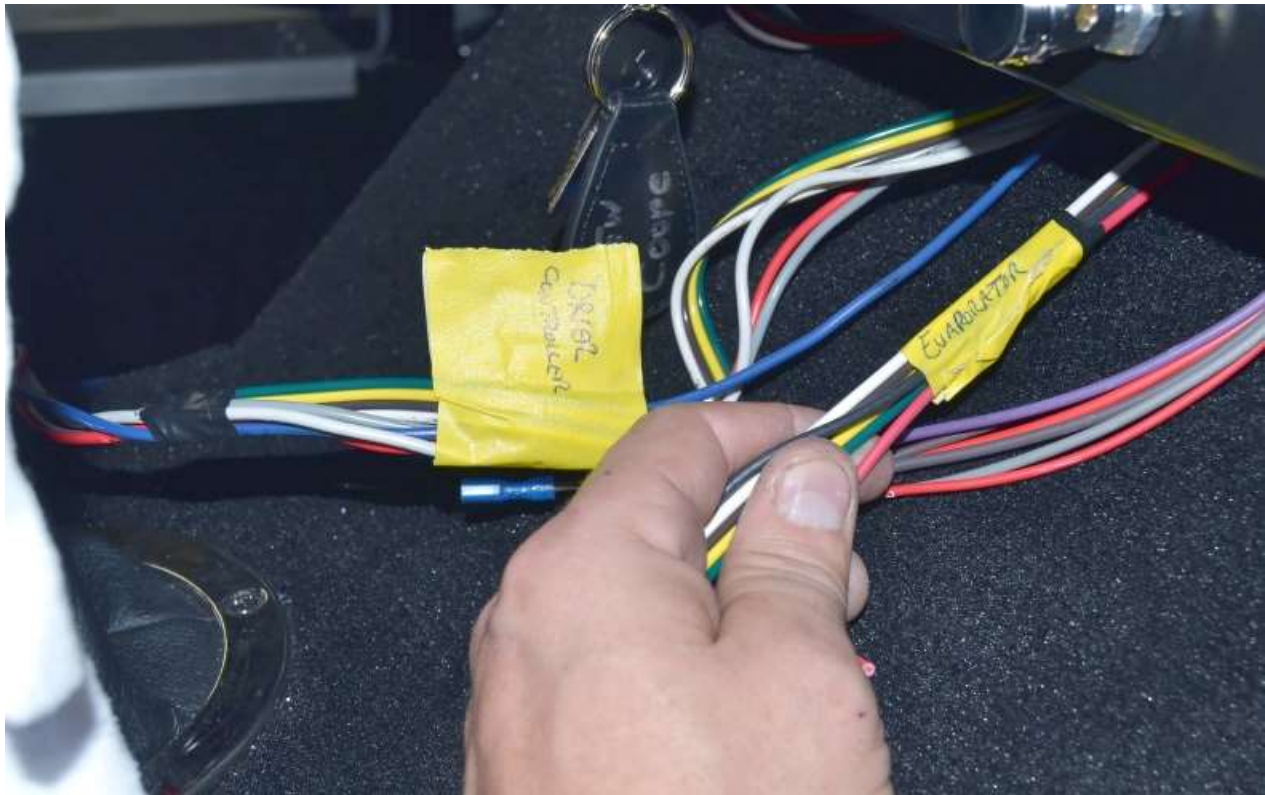

Wrap the motor wires in masking tape 6" back from the ends and write "Evaporator" on it.

CONTROL PANEL

- ✂ $\frac{1}{2}$ ", $\frac{9}{16}$ " wrenches, $\frac{1}{8}$ ", $\frac{3}{16}$ " drill bit, drill, marker, $\frac{1}{16}$ " hex key, wire cutters, wire crimpers, rivet tool, soldering iron, solder.
- 🔧 Heater control components, A/C electrical components.



Attach the A/C on-off switch to the faceplate so that the ground is at the top and power is at the bottom.



Attach the rotary switches to the dash faceplate. The fan switch has four positions and needs a $\frac{1}{16}$ " wrench. The heat control switch is smooth and needs a $\frac{1}{2}$ " wrench.



Attach the fan and heat knobs using a $\frac{1}{16}$ " Hex key.

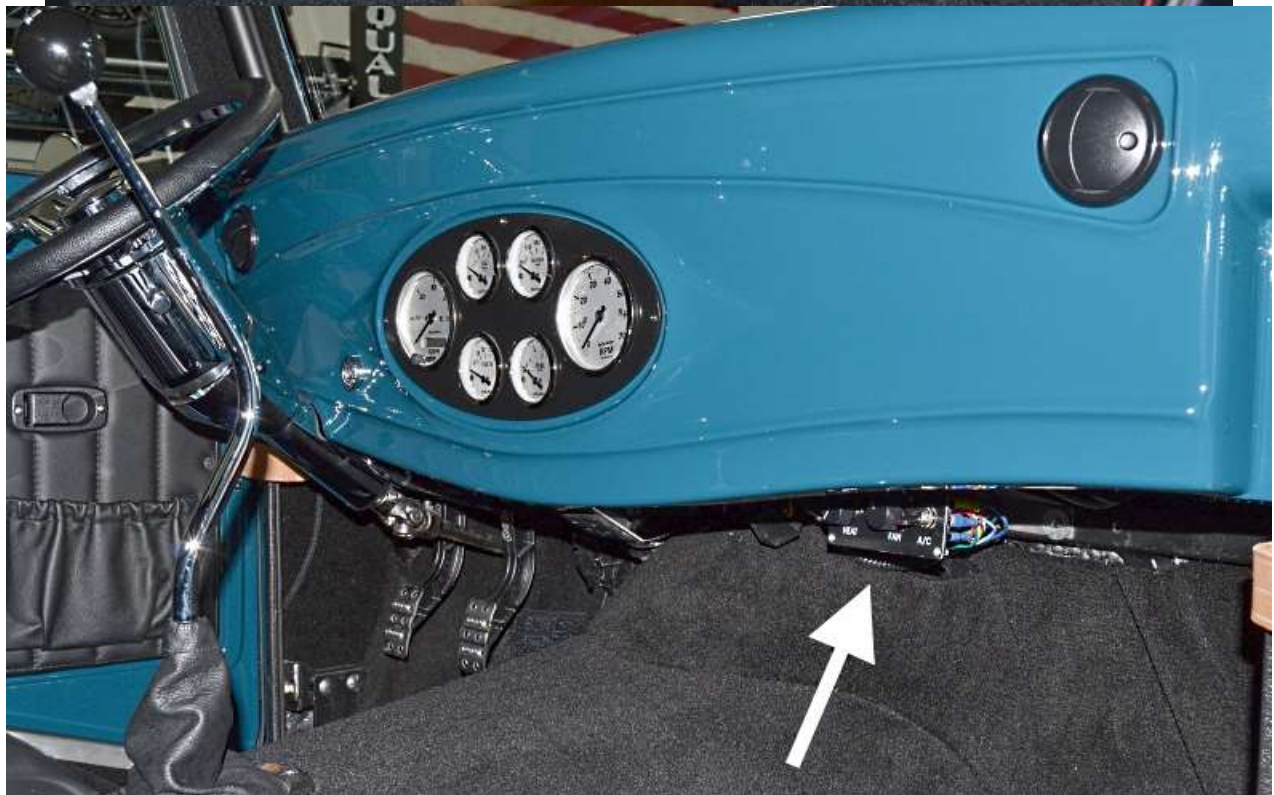

Decide how the controls will get mounted, control faceplate on the dash, use the faceplate mount under the dash where you can reach it and the wires reach (FFR Coupe dash shown top) or hidden further back under the dash on the Evaporator mounting bracket (shown lower).

If using the bracket, use the bracket holes as a template to drill $\frac{3}{16}$ " mounting holes and rivet the mounting bracket flange to the dash flange.



Pull the wires through the mounting bracket if used. (FFR Coupe dash shown)

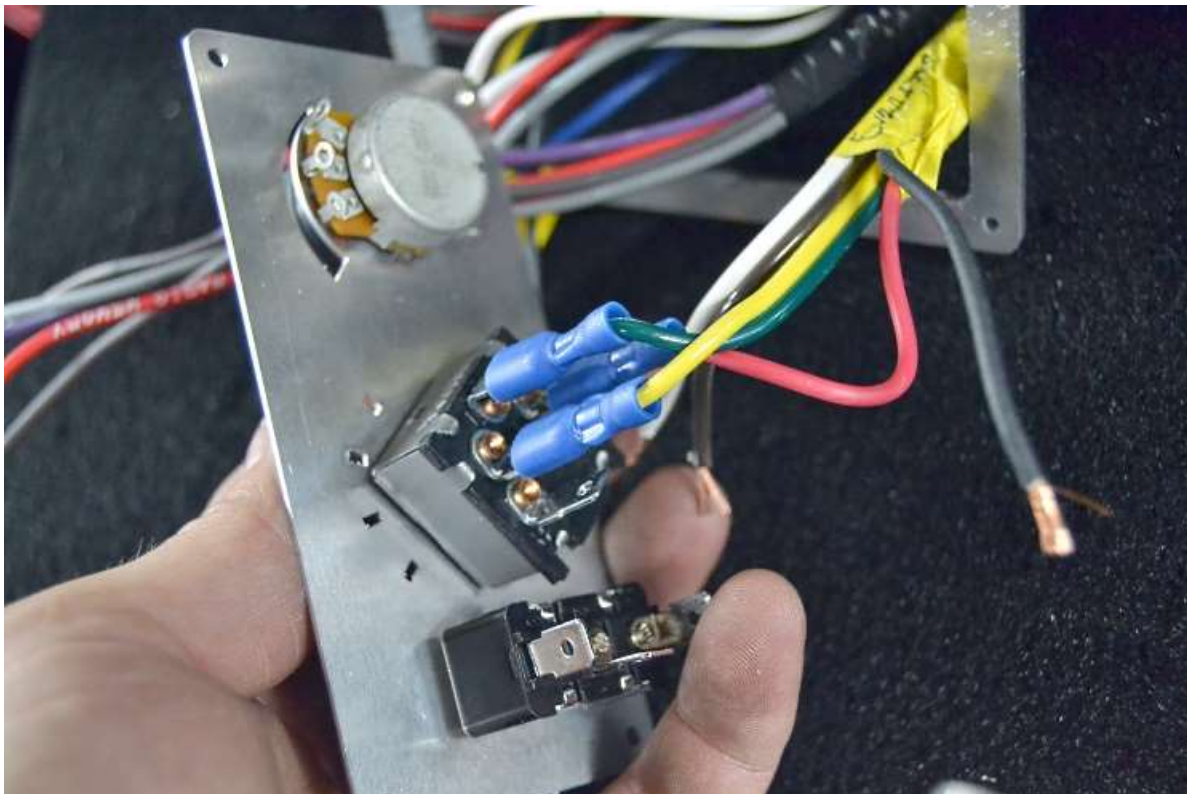

Take the “Evaporator wires and attach ¼” female connectors to the yellow, green and red wires and attach them to the rotary fan switch; **Green** on the top center “M” location, **Yellow** on the top left “L” location and the **red** on the top right location “H”.

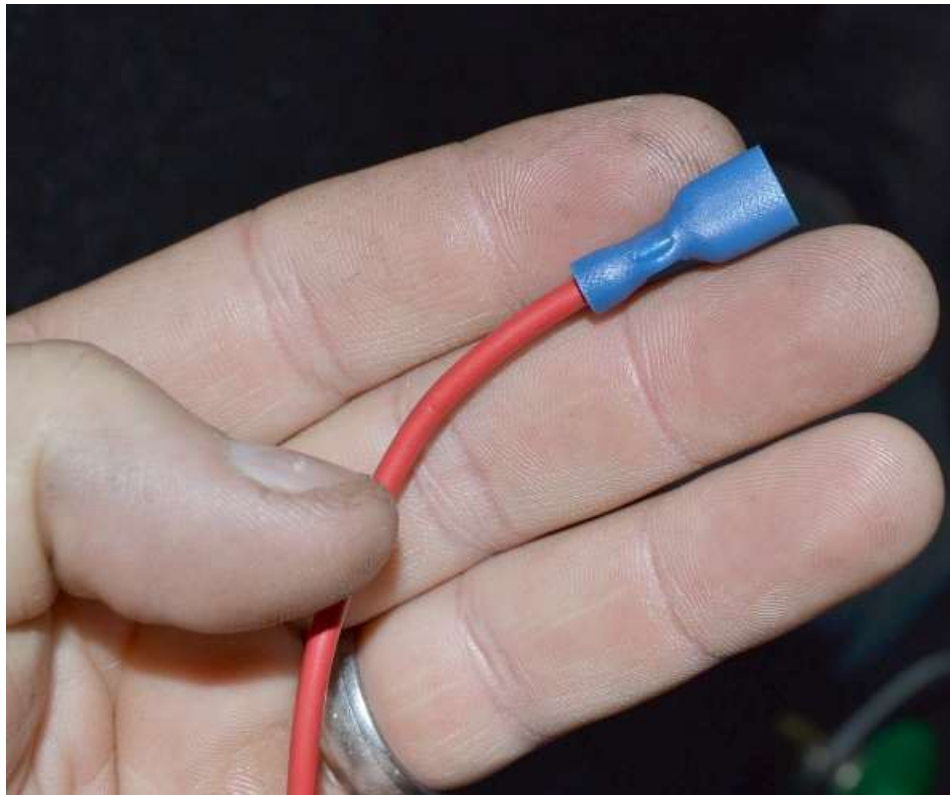

Attach a ¼" female connector to a piece of the remaining red wire.

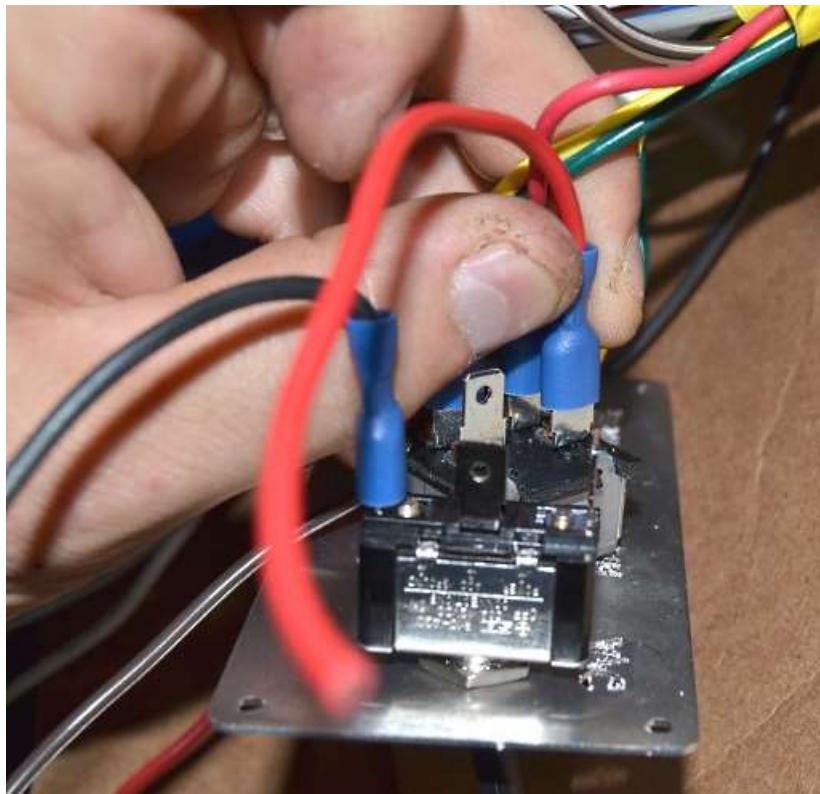

Push the connector onto the lower right "C" position on the fan switch. Attach a ¼" female connector to the end of a piece of extra black wire and push it onto the ground end of the A/C switch.

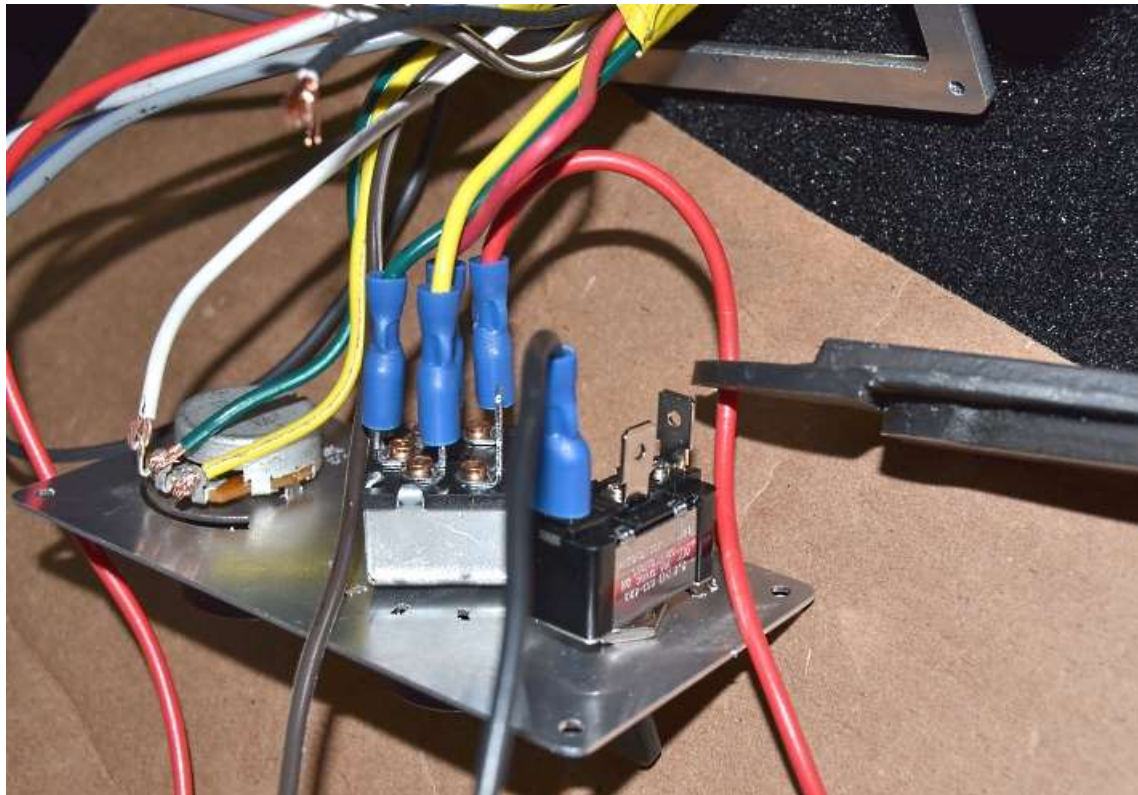

Hold the red wire over next to the lower “Power” A/C switch location and cut to length.

Attach a ¼” female connector to the end of the wire.

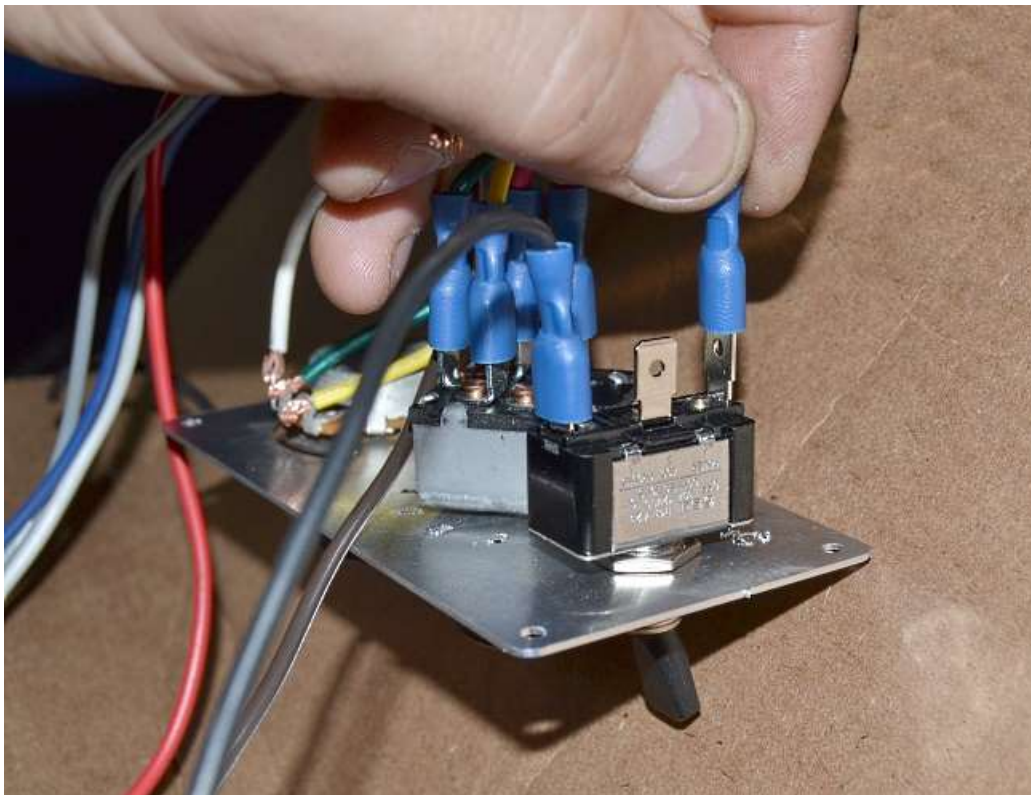

Push the red wire onto the end “Power” location.

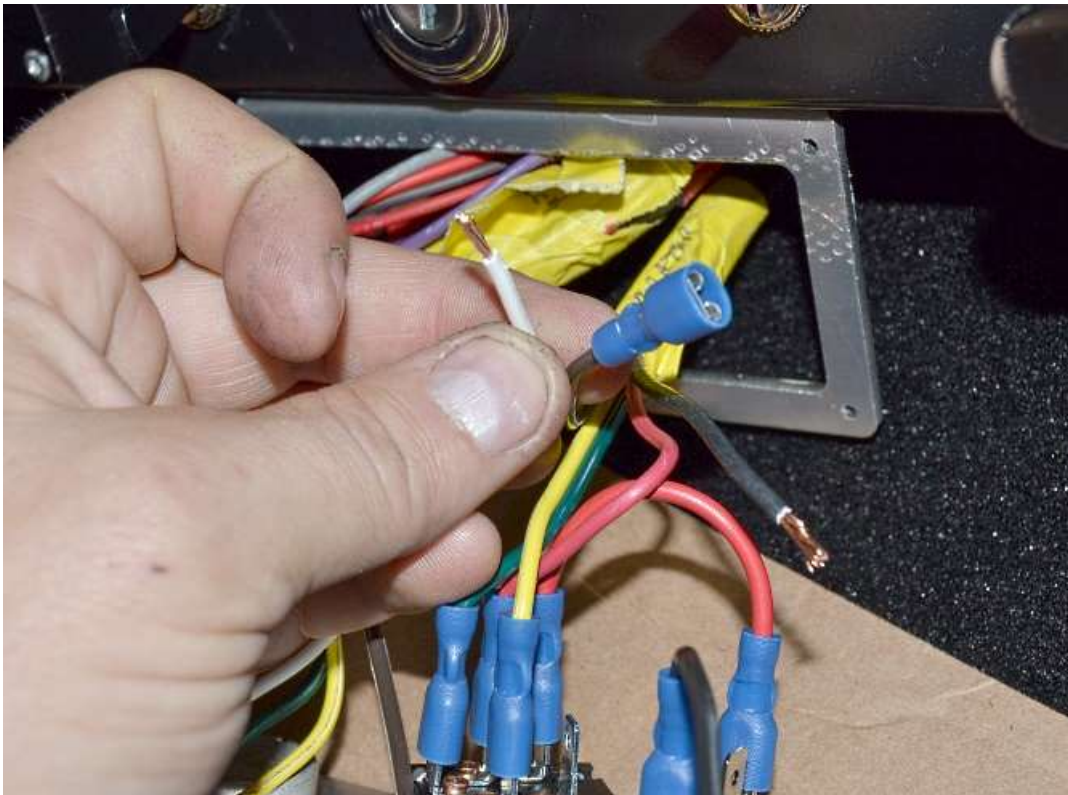

Attach a 1/4" female connector to the **brown** "Evaporator" wire.

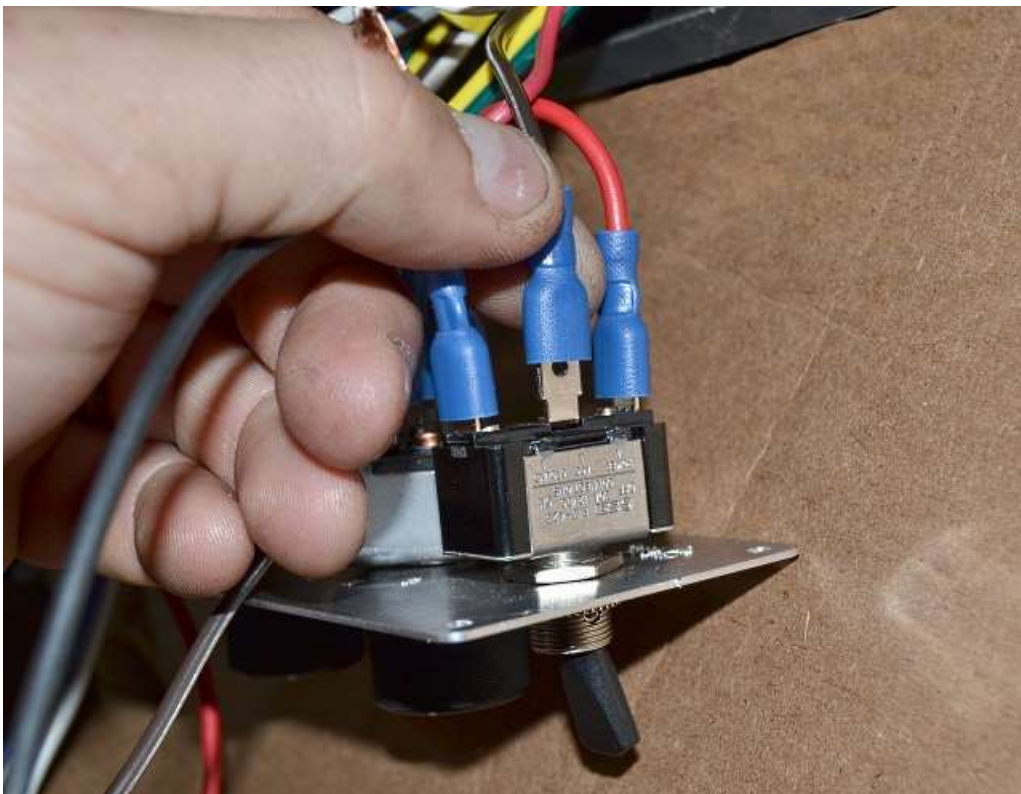

Push the brown wire onto the center of the A/C switch.



Use a blue butt connector to attach the **white** wire from the “Evaporator” to the **gray** wire from the “Drier”.



Connect the black frame ground wire and the “Evaporator” black wire in one end of the yellow butt connector.



Connect the **black** wire from the A/C switch and the brown wire from the “Drier” in the other end of the yellow butt connector.



Locate the chassis harness “**Heater**” wire.

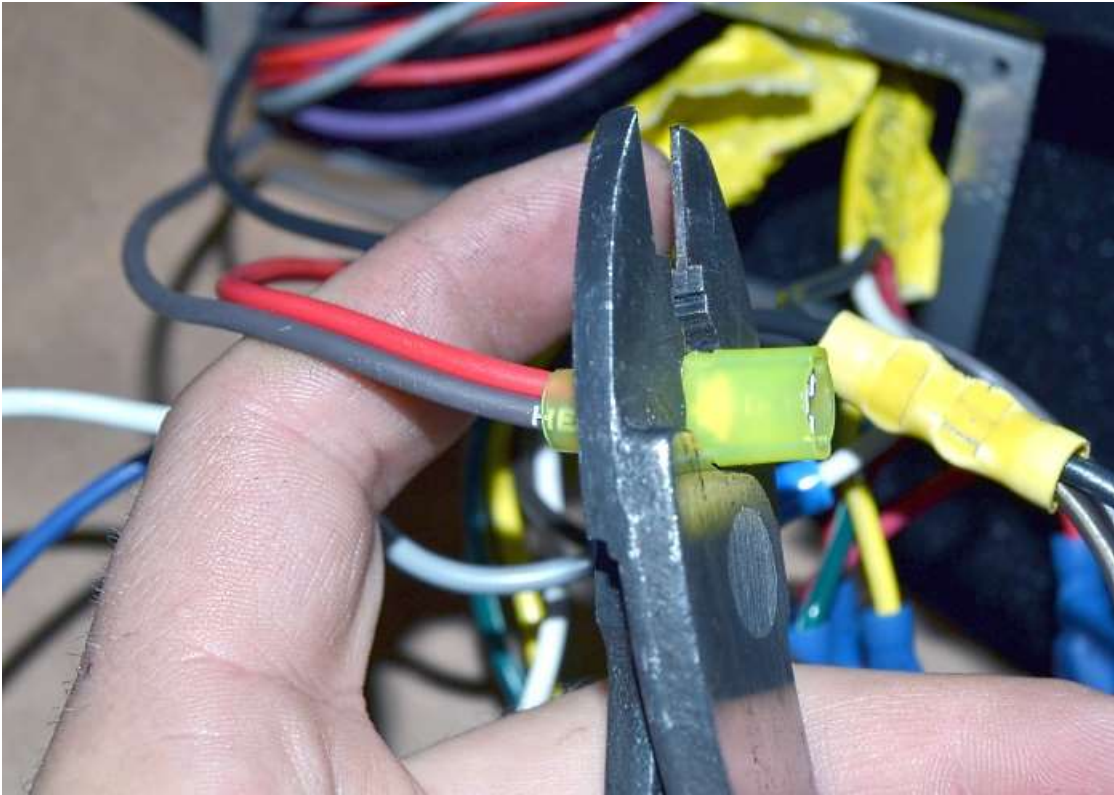

Connect the chassis harness “Heater” wire and the red wire from the “Drier” in the yellow female terminal connector.

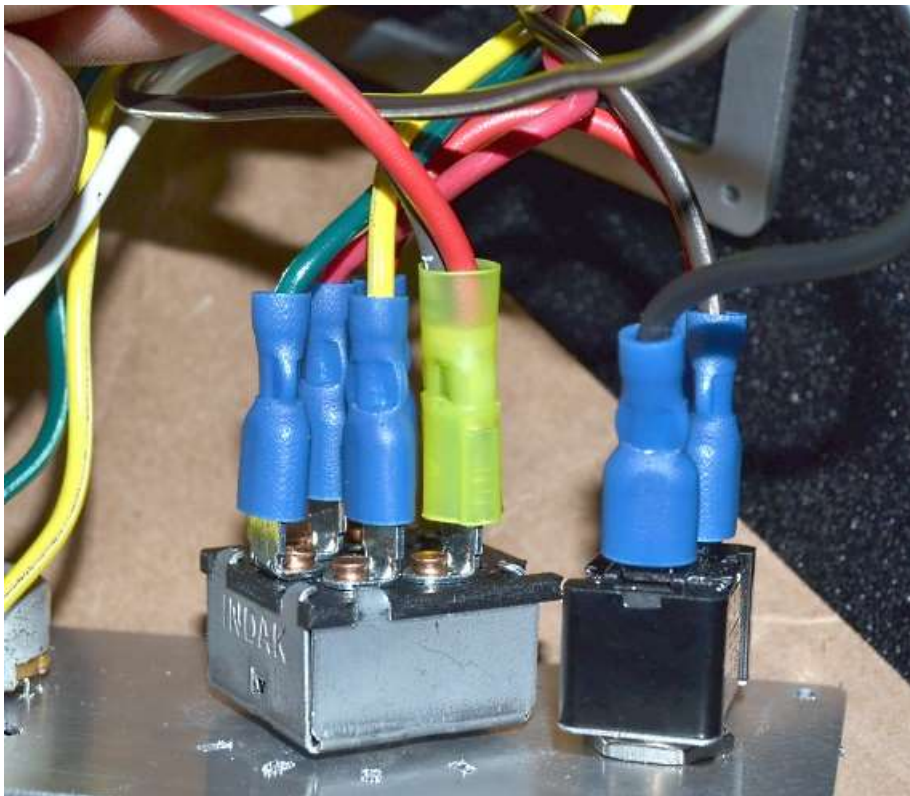

Attach the yellow female connector to the lower left “B” terminal on the fan switch.

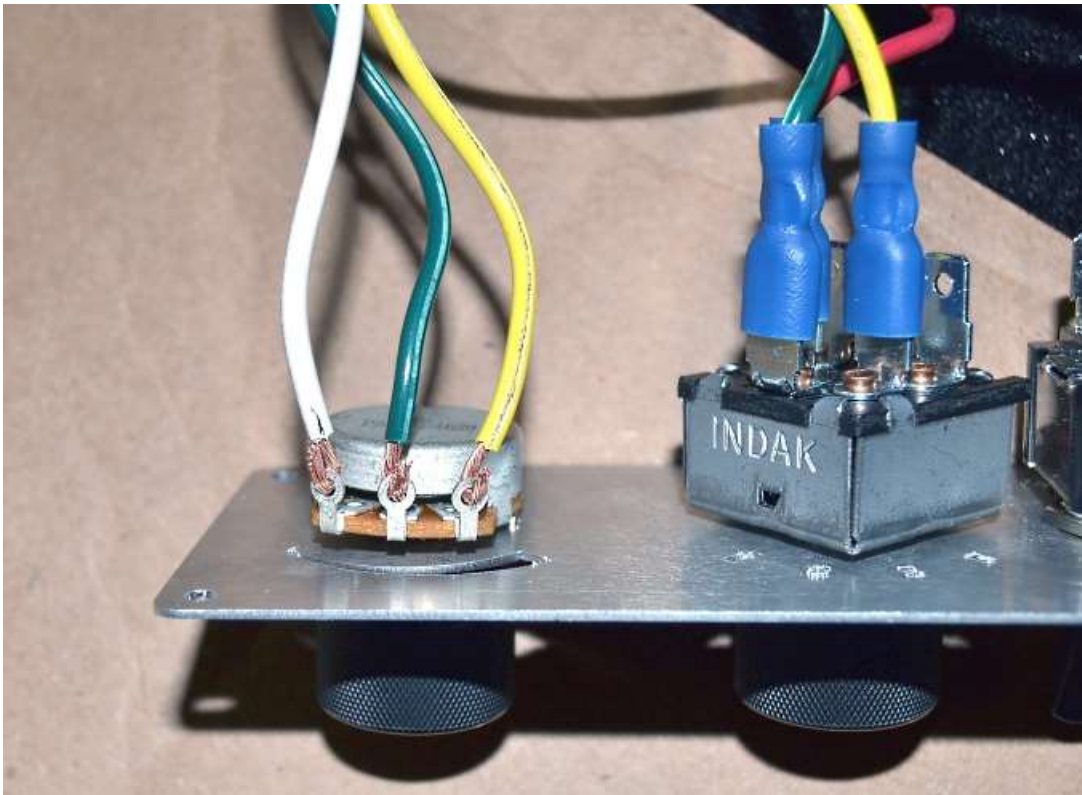

Connect the white, green and yellow wires from the “Drier” to the rotary temperature control loop terminals as shown.

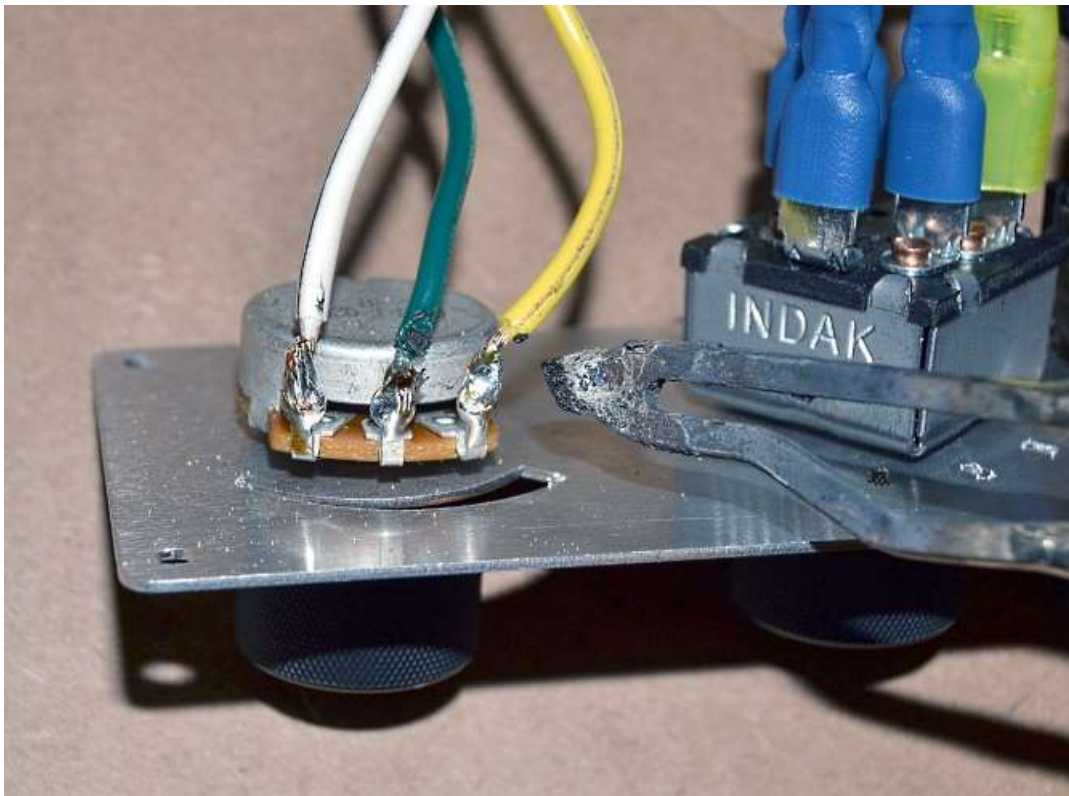

Solder the wires to the temperature switch.

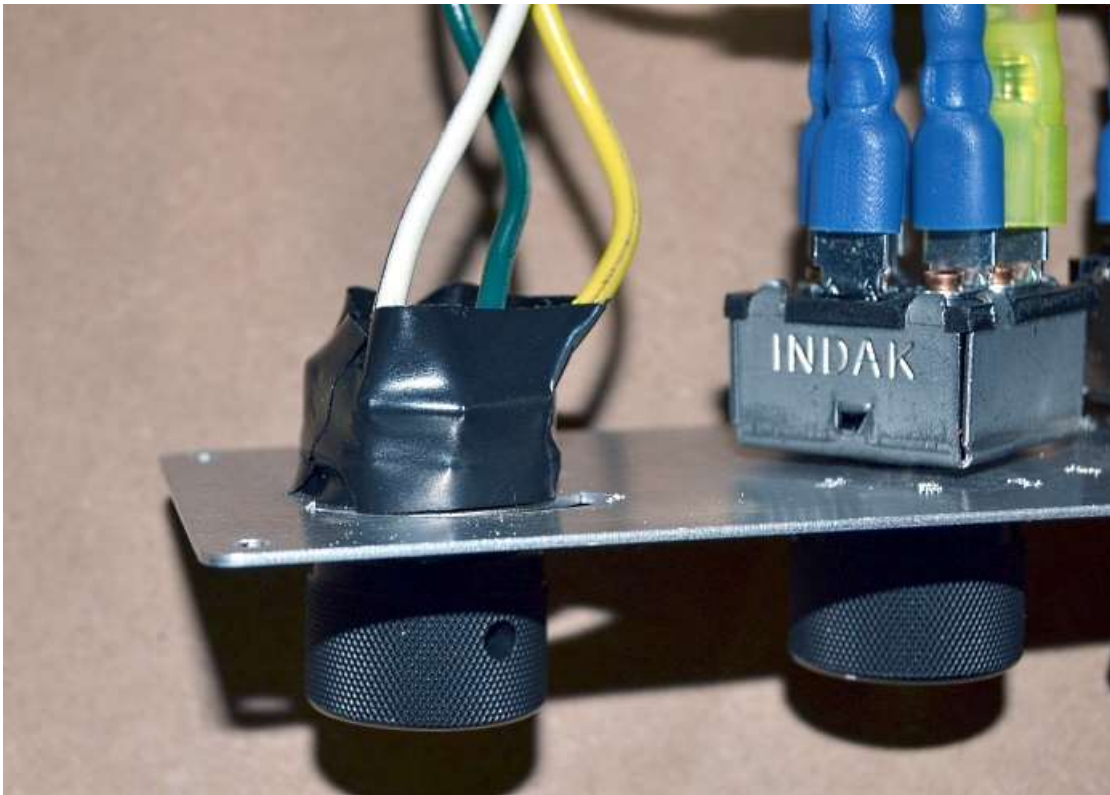

Wrap the temperature switch with electrical tape to prevent any accidental electrical contact.



Screw the faceplate to the mounting bracket.

Testing



✂ 50/50 Coolant, (2) 12oz 134a Refrigerant cans, (1) 12oz 1st charge (has oil in it)

Make sure the A/C switch is off and the fan switch is off.

If possible top up the coolant in the engine at its highest point.

Fill the coolant overflow with 50/50 engine coolant.

Start the car and get it up to operating temperature, over 185°F so the engine thermostat opens.

Turn the A/C heat temperature knob all the way up so the coolant runs through the evaporator heater core.

Shut the engine off and let it cool so coolant will get sucked in from the overflow.

Once the engine has cooled, check the overflow. If empty refill and cycle the engine again. If there is coolant left, fill half way and continue.

Charge the A/C system and check for leaks.

Hose insulation

✋ Charge and make sure the system does not leak before insulating hoses.

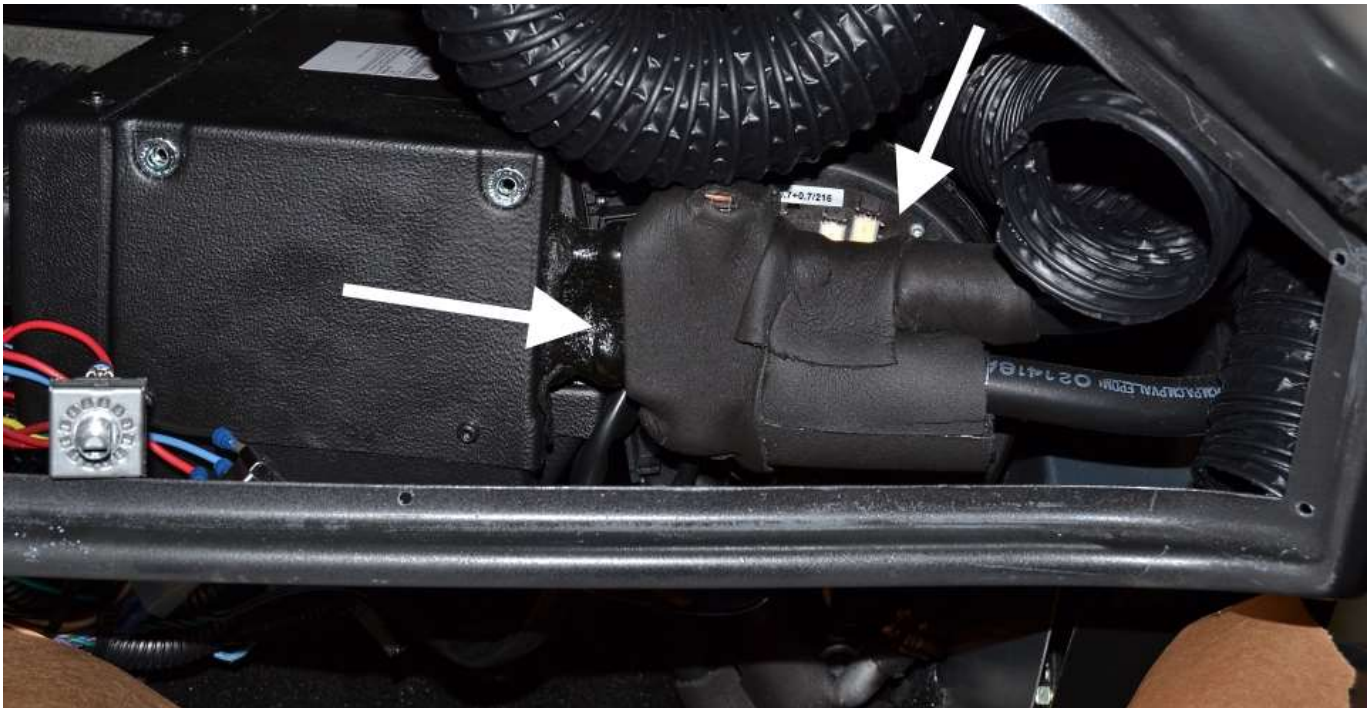

Use the thin $\frac{1}{8}$ " insulation to cover the evaporator block and #6 hose to the firewall.

Wrap the #10 hose and fittings with the $\frac{3}{4}$ " pipe insulation.

Hose Diagram

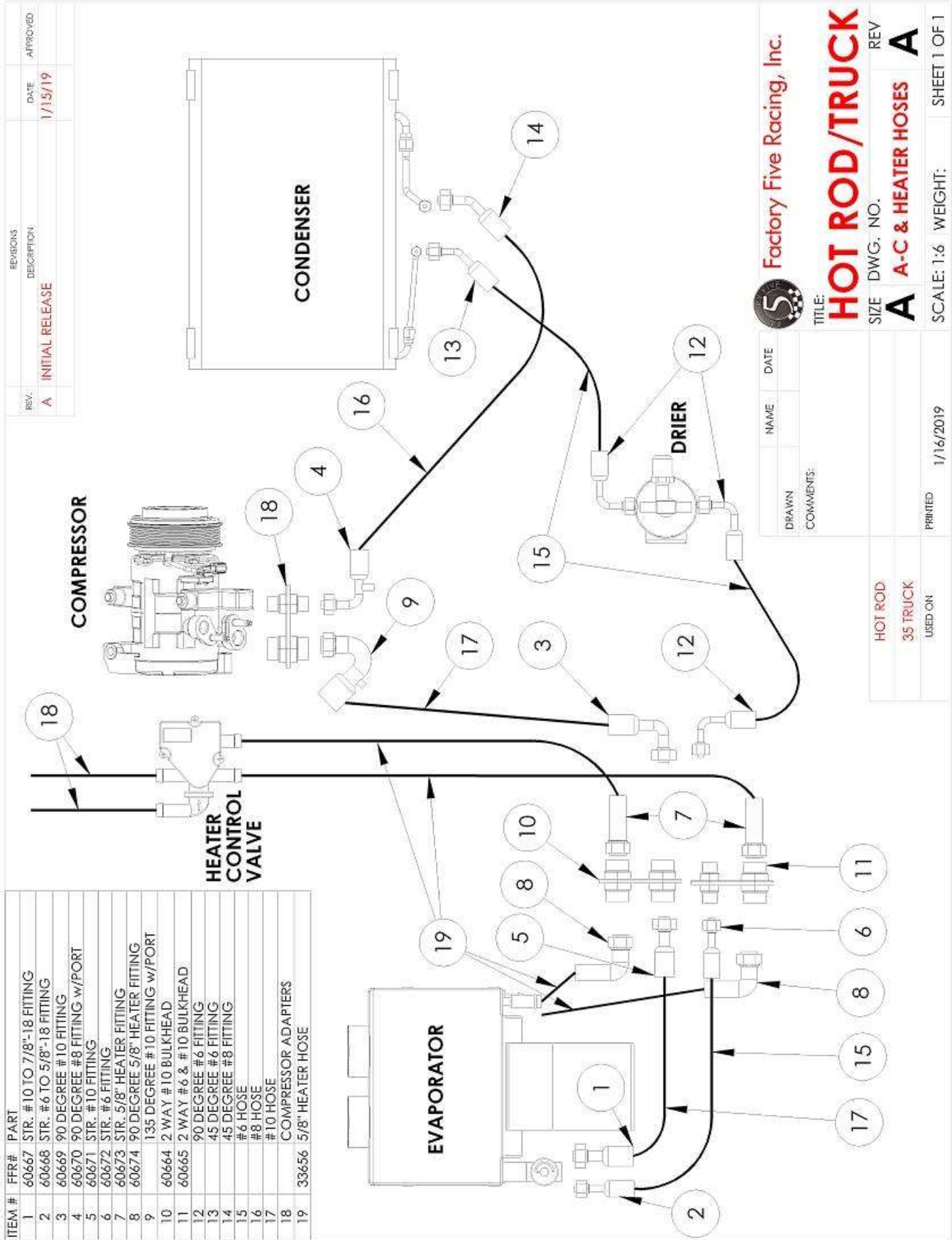

ITEM #	FR#	PART
1	60667	STR. # 10 TO 7/8"-18 FITTING
2	60668	STR. # 6 TO 5/8"-18 FITTING
3	60669	90 DEGREE # 10 FITTING
4	60670	90 DEGREE # 8 FITTING w/PORT
5	60671	STR. # 10 FITTING
6	60672	STR. # 6 FITTING
7	60673	STR. 5/8" HEATER FITTING
8	60674	90 DEGREE 5/8" HEATER FITTING
9	60664	135 DEGREE # 10 FITTING w/PORT
10	60664	2 WAY # 10 BULKHEAD
11	60665	2 WAY # 6 & # 10 BULKHEAD
12		90 DEGREE # 6 FITTING
13		45 DEGREE # 6 FITTING
14		45 DEGREE # 8 FITTING
15		# 6 HOSE
16		# 8 HOSE
17		# 10 HOSE
18		COMPRESSOR ADAPTERS
19	33656	5/8" HEATER HOSE

REV.	DESCRIPTION	DATE	APPROVED
A	INITIAL RELEASE	1/15/19	

5 Factory Five Racing, Inc.

TITLE: **HOT ROD/TRUCK**

SIZE DWG. NO. **A** REV **A**

SCALE: 1:6 WEIGHT: SHEET 1 OF 1

PRINTED: 1/16/2019

USED ON: HOT ROD, 35 TRUCK

DRAWN: NAME: DATE: COMMENTS:

Wiring diagram

