



Factory Five Racing, Inc.

Part Number: 16303      Revision: A      Effective Date: 3/12/19      By: J. INGERSLEV

# 2015 IRS 11.65" BRAKES

## INSTALLATION INSTRUCTIONS

ITEM NO.	PART NUMBER	DESCRIPTION	16765/QTY.
1		LEFT SIDE SPINDLE	1
2		REAR BRAKE CALIPER	1
3	16767	M12-1.50 X 60mm BOLT	1
4	14759	M14-2.0 FLANGED LOCK NUT	1
5	14779	M12-1.75 X 45mm BOLT	1
6	16248	11.65" ROTOR	1
7	16766	11.65" ROTOR IRS CALIPER BRACKET	1
8	14775	IRS CALIPER SPACER	2
9	15275	1/2" ID x 7/8" OD x 0.075" SHIM	2
10	13976	1/2" WASHER	1
11	16301	M14 x 50mm BOLT	1
12	16774	M12-1.75 x 45MM 12 POINT BOLT	1

REV.	DESCRIPTION	DATE	APPROVED
A	INITIAL RELEASE	3/11/19	

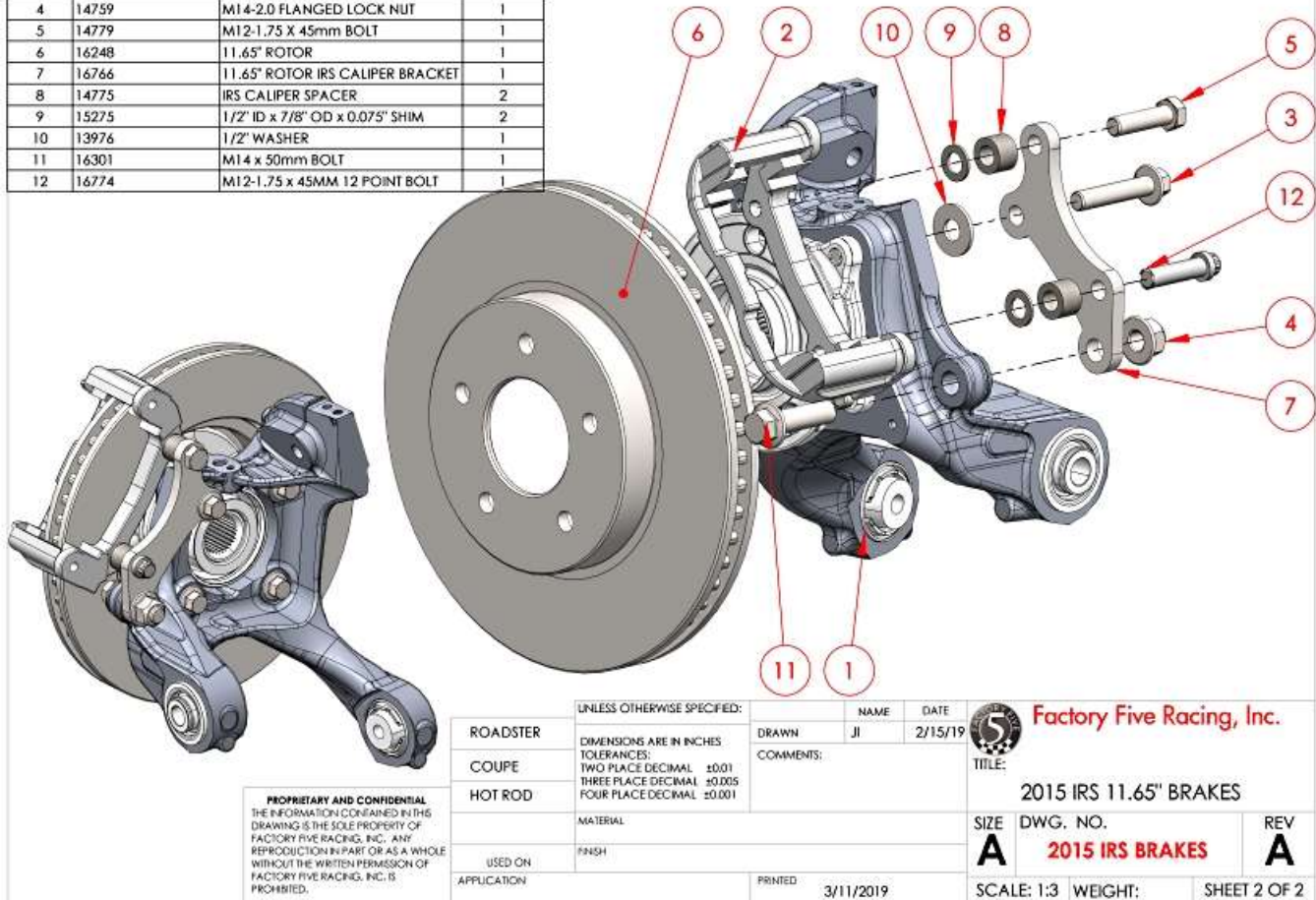

**PROPRIETARY AND CONFIDENTIAL**  
 THE INFORMATION CONTAINED IN THIS DRAWING IS THE SOLE PROPERTY OF FACTORY FIVE RACING, INC. ANY REPRODUCTION IN PART OR AS A WHOLE WITHOUT THE WRITTEN PERMISSION OF FACTORY FIVE RACING, INC. IS PROHIBITED.

ROADSTER	UNLESS OTHERWISE SPECIFIED:	NAME	DATE	<b>Factory Five Racing, Inc.</b>
COUPE	DIMENSIONS ARE IN INCHES	JL	2/15/19	
HOT ROD	TOLERANCES:	COMMENTS:		TITLE:
	TWO PLACE DECIMAL ±0.01			2015 IRS 11.65" BRAKES
	THREE PLACE DECIMAL ±0.005			SIZE DWG. NO. REV
	FOUR PLACE DECIMAL ±0.001			<b>A</b> <b>2015 IRS BRAKES</b> <b>A</b>
	MATERIAL	PRINTED 3/11/2019		SCALE: 1:3 WEIGHT: SHEET 2 OF 2
	FINISH			
USED ON	APPLICATION			

Left side shown.

## Table of Contents

Tools needed .....	2
Spindle prep .....	2
Caliper Prep – Roadster only .....	4
Brake Pads.....	5
Left side bracket assembly.....	6
Brake caliper installation .....	7
E-Brake cables.....	8

## Tools needed

12mm 12 point, 15mm, 18mm, 19mm sockets,  $\frac{13}{16}$ " wrench, Ratchet, Torque wrench, Sawzall, marker, impact wrench.

## Spindle prep

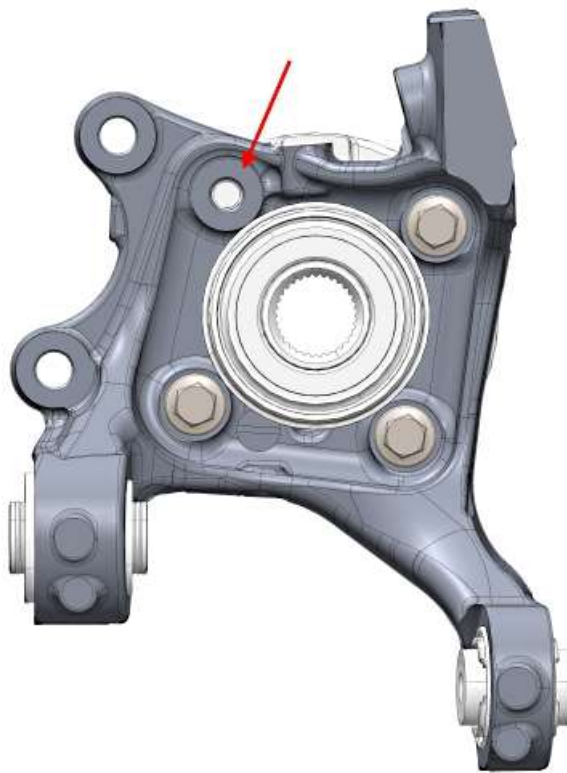

Remove the rear top bolt holding the bearing/hub to the spindle using a 15mm socket and impact wrench.

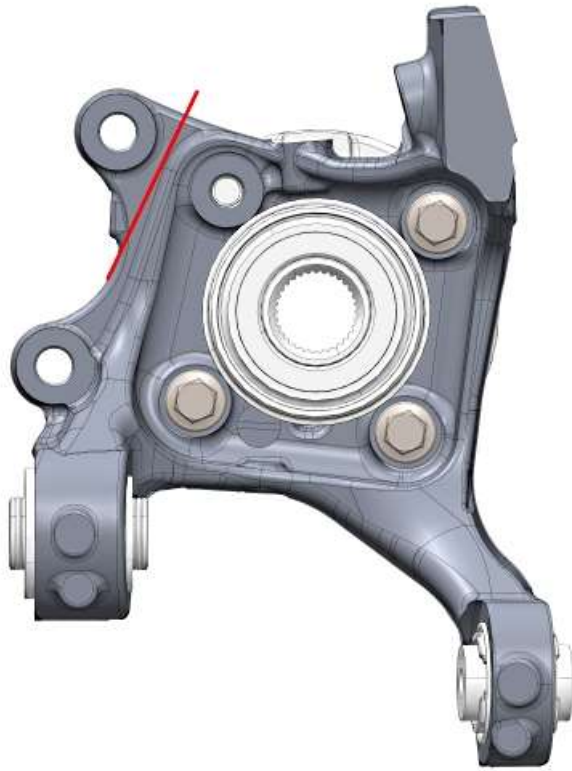

Mark the top brake caliper ear.



Use a Sawzall to cut the caliper ear off.

## Caliper Prep – Roadster only



This is for the Roadster only, not the Hot Rod or Coupe



Use a ½” drill bit and run it through the E-brake cable mounting hole then pull it down slightly to oval the hole out.

## Brake Pads

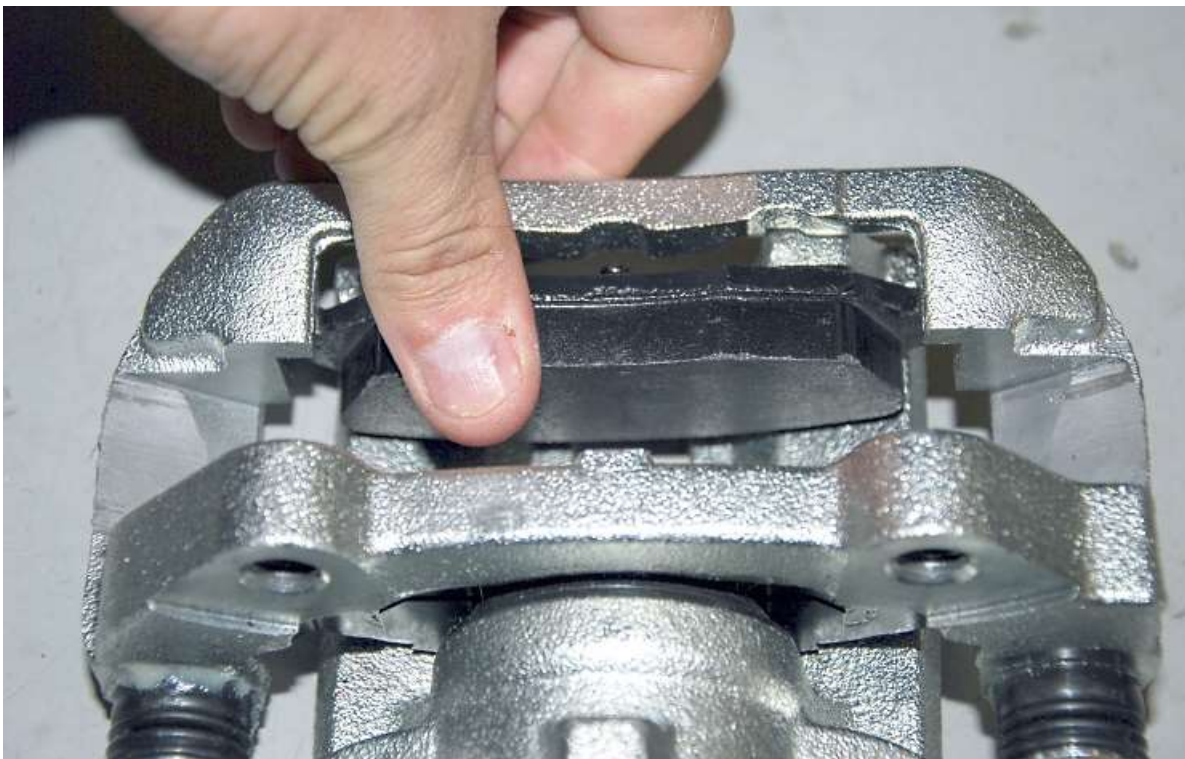

If not already in, insert the pads into the caliper.

## Left side bracket assembly



Run the 60mm bolt through the laser cut bracket and 1/2" washer.

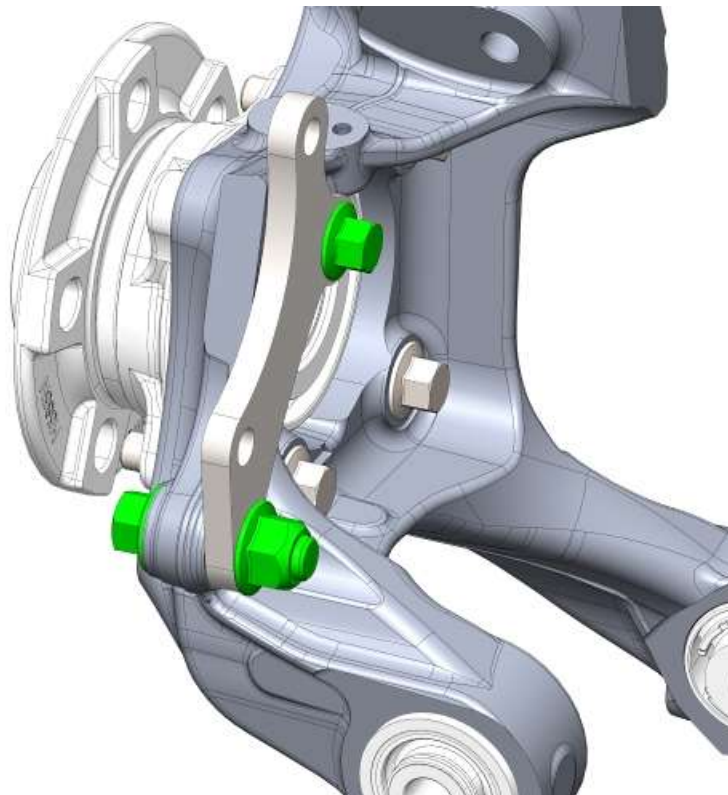

Attach the top bracket bolt to the spindle bearing/hub location and run the larger 14mm bolt from the hub side in. Torque the top bolt to **133 Nm (98 lb-ft)** then rotate **45°**. Torque the lower bolt to **133 Nm (98 lb-ft)**.

Put the rotor on the spindle and hold it in place with a lug nut.

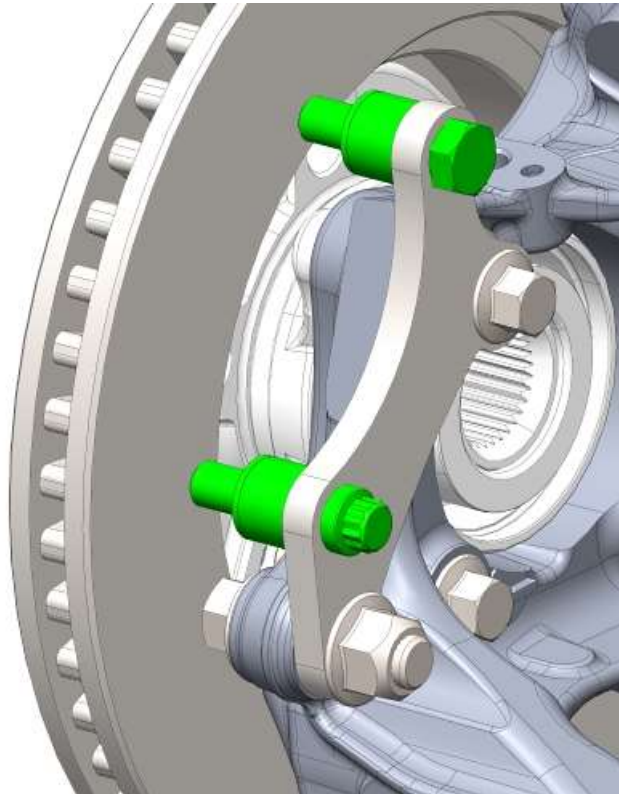

Run the 45mm Hex bolt through the top bracket hole and the 12 point bolt through the bottom followed by the spacers then the shims.

Repeat this assembly for the right side.

## Brake caliper installation

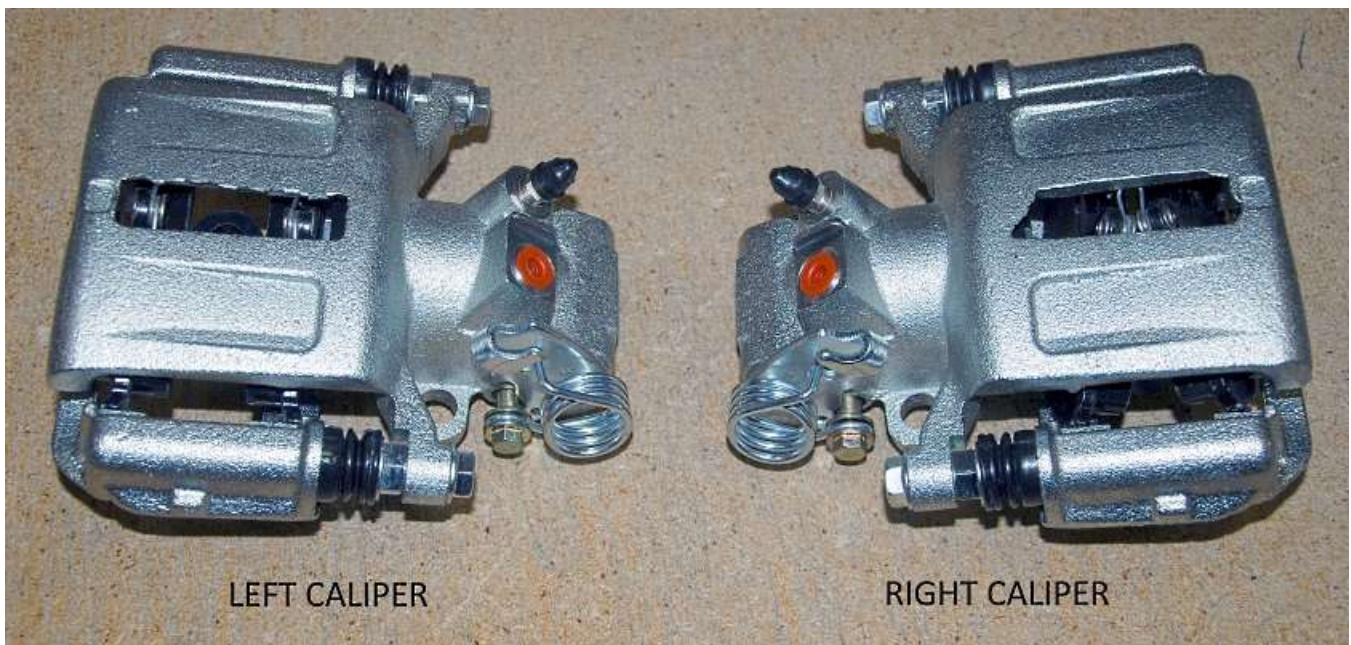

Note the bleeder screw and spring locations.

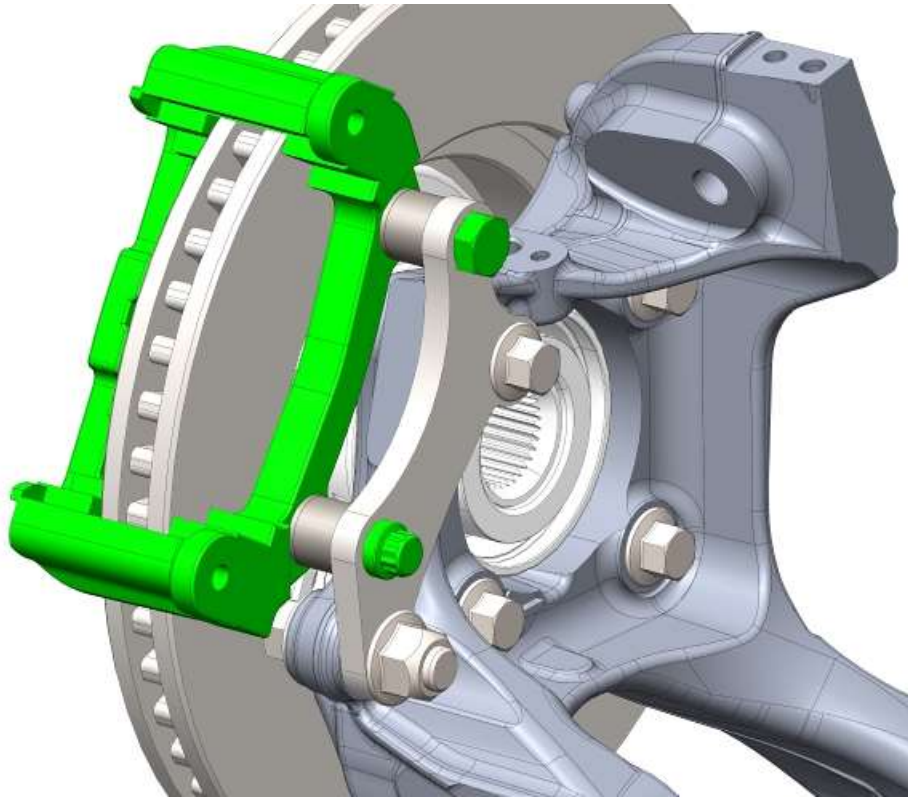

Attach the brake caliper to the bracket. Make sure the bleeder screw is at the top. Make sure the caliper bracket is centered on the rotor. If necessary remove the thin shims.

Torque the caliper to bracket bolts to **88-101 Nm (65-75 lb-ft)**.

## E-Brake cables



On the end of the Emergency brake cable sheath with no clip on, pull/push the cable so that 3" of cable sticks out of the sheath.



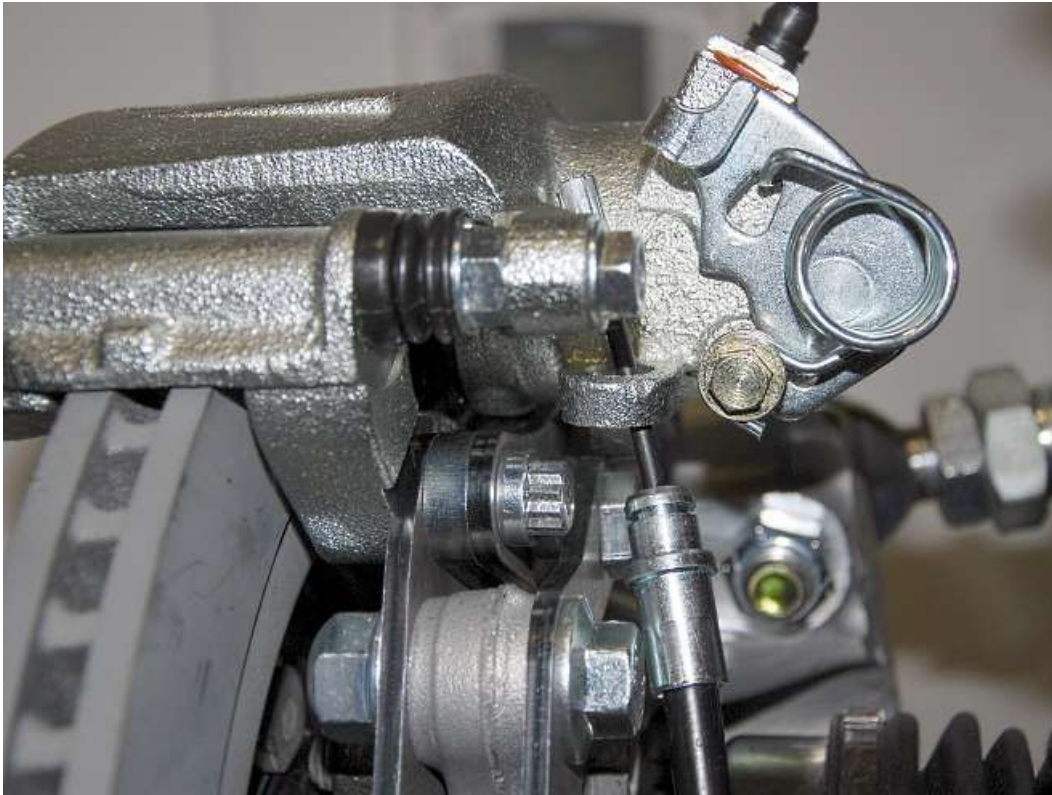

From the bottom, insert the cable through the hole in the brake caliper.

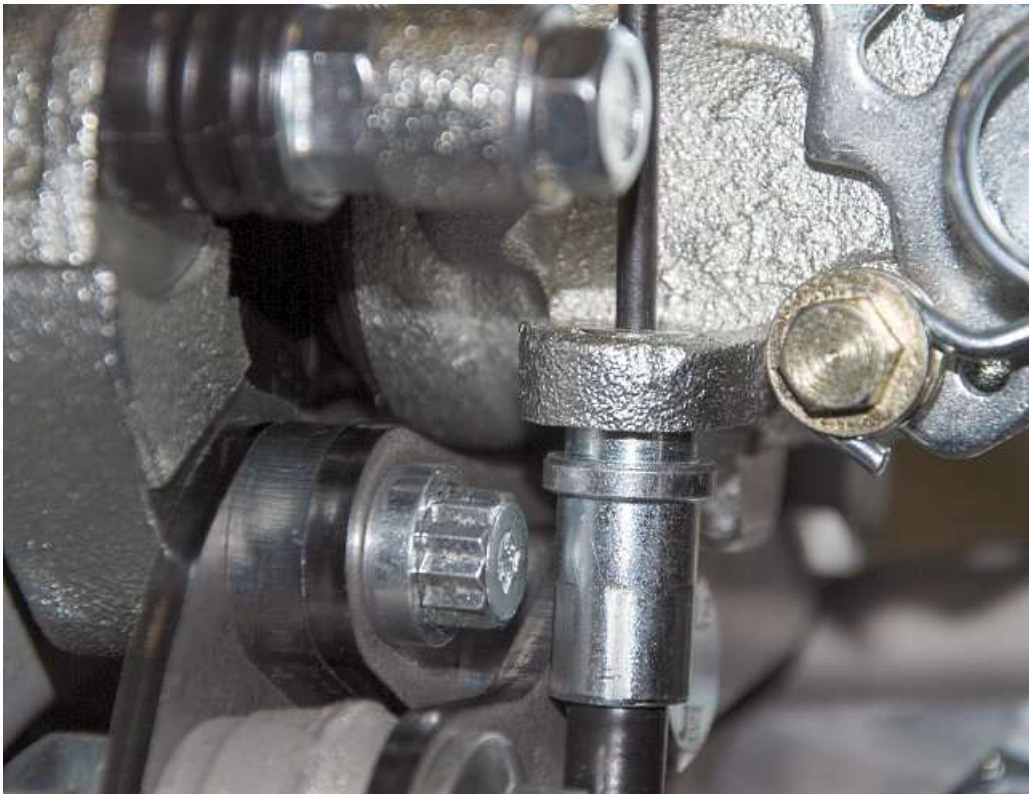

Push the end of the sheath into the hole. The end of the sheath may or may not bottom on the flange. It is normal for the sheath to look like the picture, the end is being held in place and cannot move.

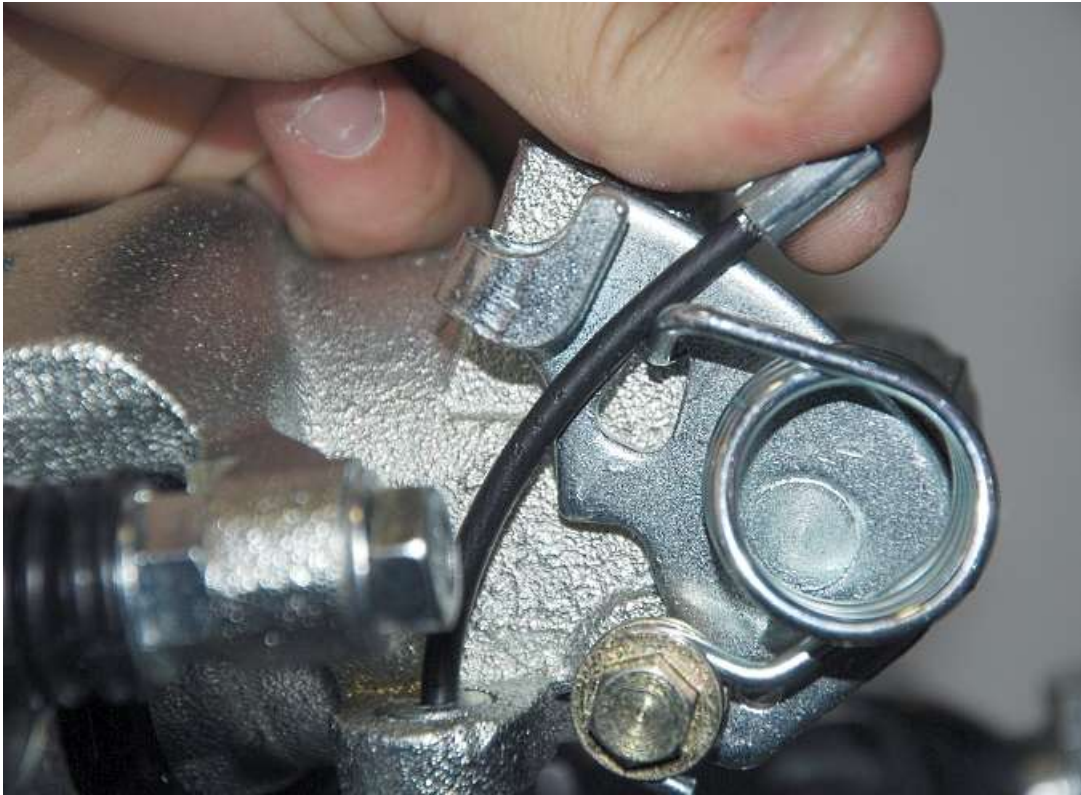

Move the end of the cable around the spring bracket so it will be captured.



Push the cable so that the end of the cable sits on the spring bracket.



Route the cable back behind the shock and towards the middle of the car.



Route the cable up over the center section and to the bracket in the transmission tunnel.



Insert the cables until the sheath end clicks in place. Roadster shown.

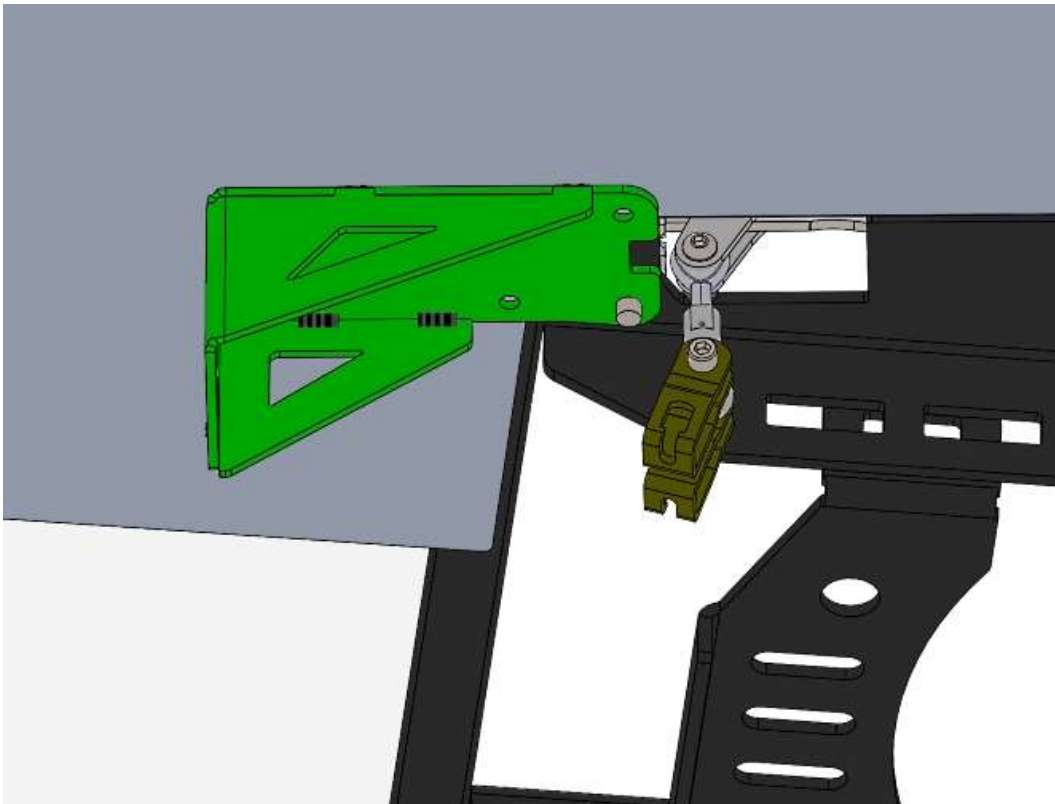

On the Hot Rod, Push the cables into the bracket behind the e-brake handle on the frame.

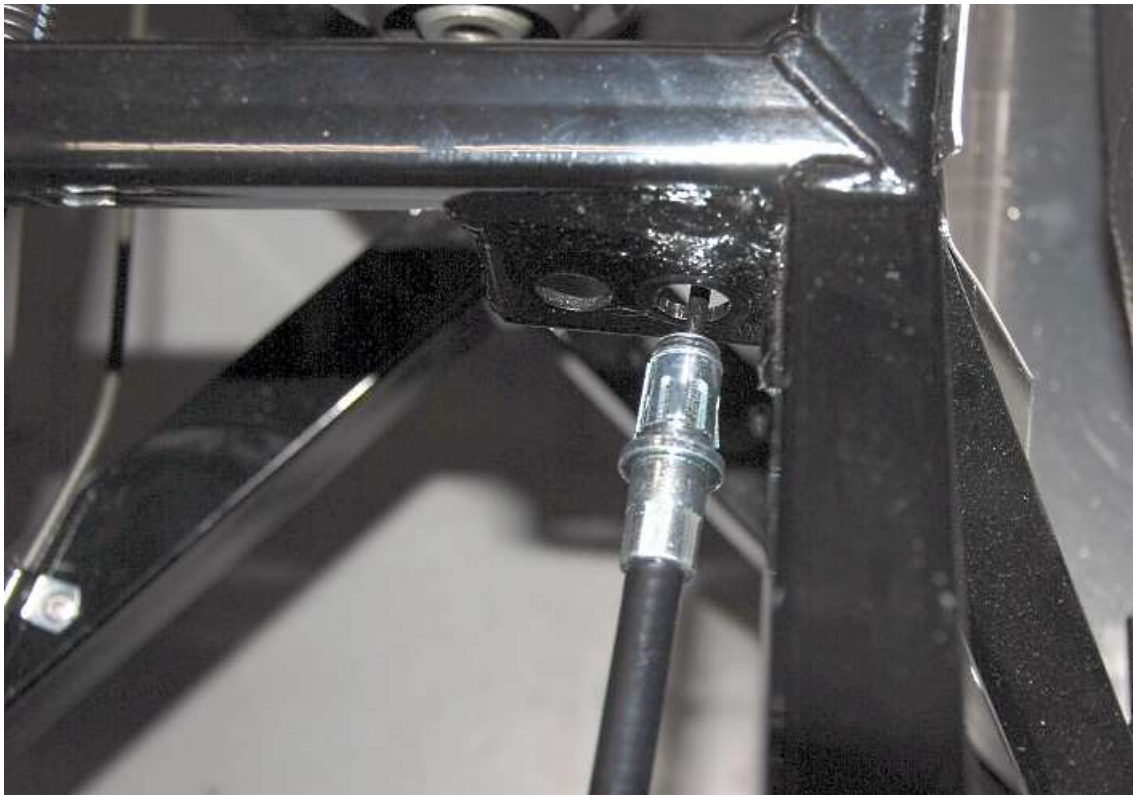

For the Coupe, push one of the cables through the bracket in the transmission tunnel until the sheath end clicks in place.