



# Seat Track

## INSTALLATION INSTRUCTIONS

### Table of Contents

Tools required .....	1
Roadster/Coupe Installation .....	1
Hot Rod Instructions.....	5

 These instructions do not apply to the GTM.

### Tools required

 Jack, Jack stands, 1/2" socket, 3/8" socket, ratchet, 3/16", 5/16" drill bits, ruler, marker, 3/16" Hex Key

### Roadster/Coupe Installation

Slide the seat tracks forward and turn the seat track upside down.  
Mark 1/8" back from the side of the square hole.



Use a  $\frac{3}{16}$ " drill bit at the point marked on the tracks then open this up with a  $\frac{5}{16}$ " drill bit.

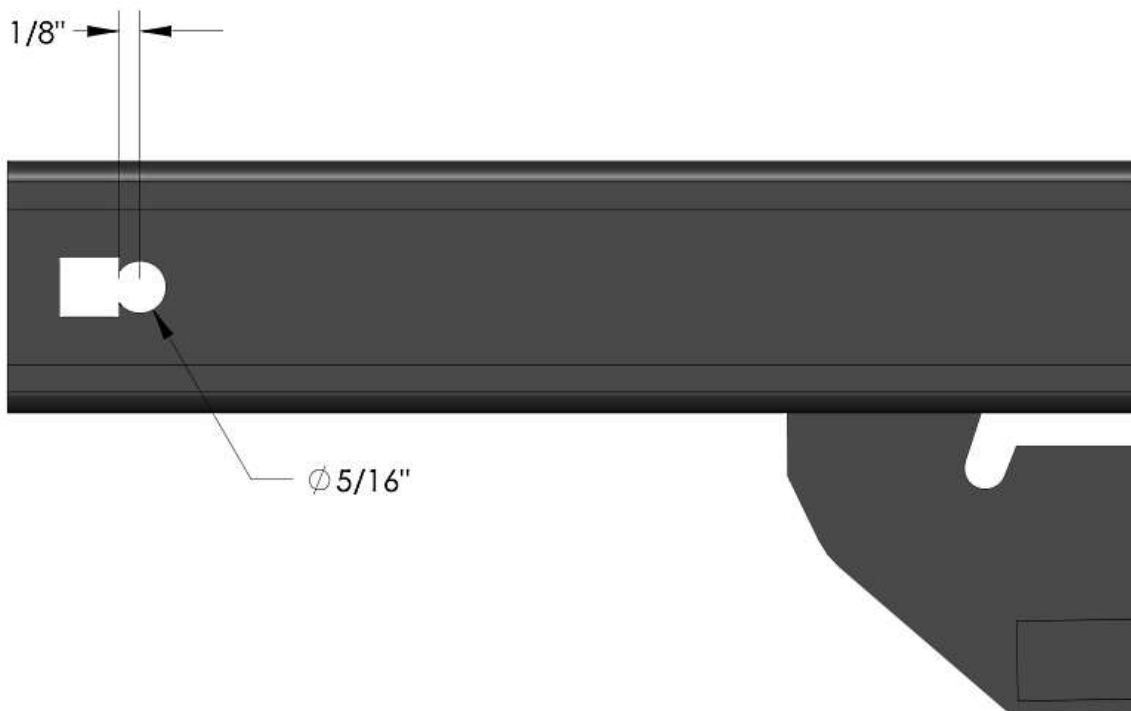

Mark the front bolt location in the rectangular hole on top of the seat tracks (wide side)  $\frac{1013}{16}$ " from the center of the rear square hole.

Jack the Driver side of the car up and place on jack stands.

ITEM NO.	PART NUMBER	DESCRIPTION	Default/Qty.
1	TOP	TOP	1
2	TOP	TOP WITH HANDLE	1
3	12776	5/16"-18 x 1.5" BUTTON HEAD BOLT	4
4	11267	5/16" NUT	4
5	13963	NYLON INSERT LOCKNUT, 5/16-18 UNC	6
6	10861	#14 X 1.50" SCREW	2
7	12591	5/16"-18 x 2.75" BUTTON HEAD BOLT	1
8	11024	5/16"-18 x 1" BUTTON HEAD BOLT	1
9	11005	5/16" WASHER	6

REV.	DESCRIPTION	DATE	APPROVED
A	INITIAL RELEASE	7/2/02	
B	FASTENER CHANGE	5/13/11	
C	FASTENER CHANGE	3/2/18	

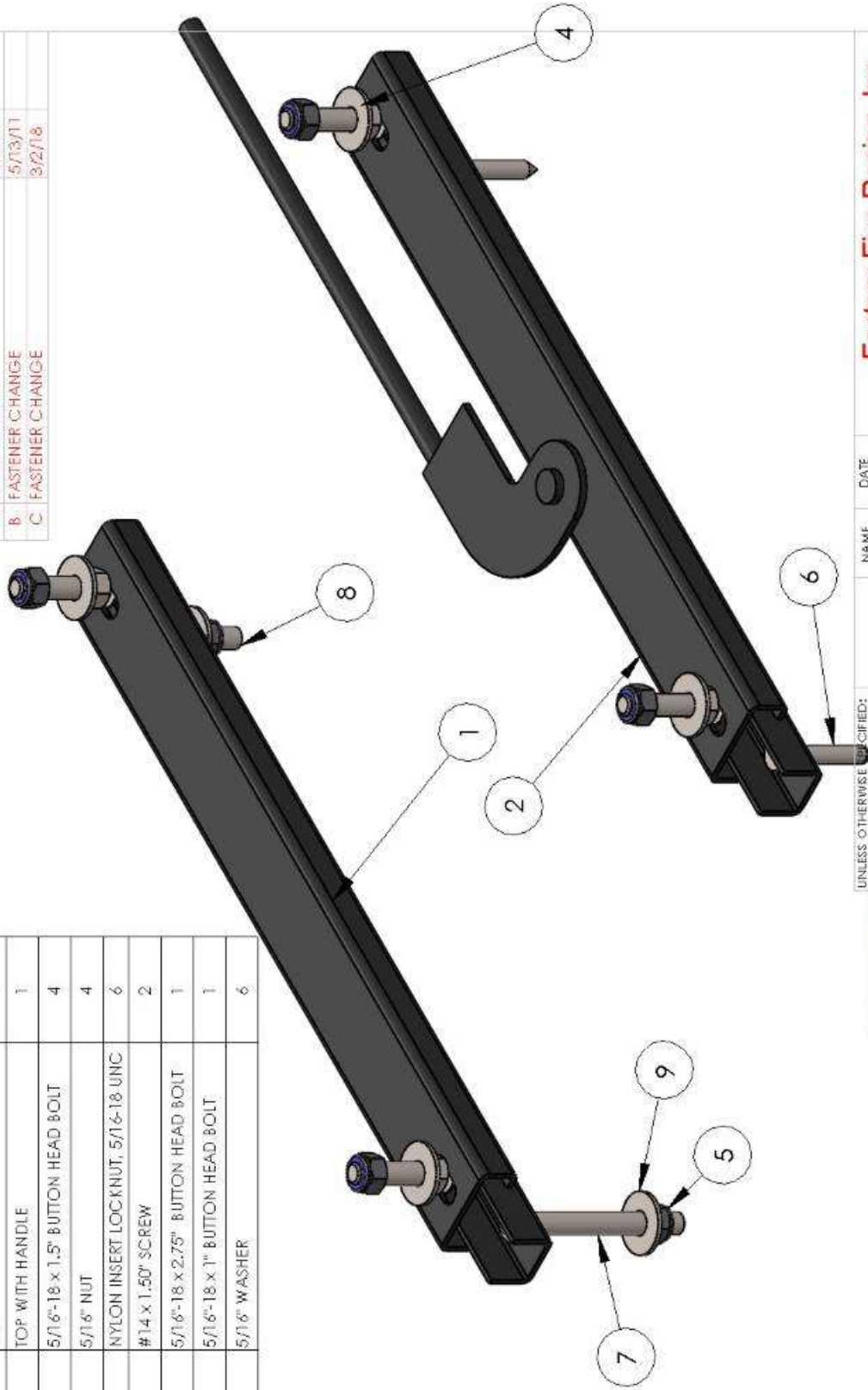

UNLESS OTHERWISE SPECIFIED:		NAME	DATE
ROADSTER	DIMENSIONS ARE IN INCHES	JL	5/13/11
COUPE	TOLERANCES:	COMMENTS:	
HOT ROD	TWO PLACE DECIMAL ±0.01		
	THREE PLACE DECIMAL ±0.005		
	FOUR PLACE DECIMAL ±0.001		
USED ON	MATERIAL	TITLE:	
APPLICATION	FINISH BLACK	SEAT TRACK ASSEMBLY	
		SIZE	DWG. NO.
		A	10809
		SCALE: 1:2	WEIGHT:
			SHEET 1 OF 2

**Factory Five Racing, Inc.**

**PROPRIETARY AND CONFIDENTIAL**  
 THE INFORMATION CONTAINED IN THIS DRAWING IS THE SOLE PROPERTY OF FACTORY FIVE RACING, INC. ANY REPRODUCTION IN PART OR AS A WHOLE WITHOUT THE WRITTEN PERMISSION OF FACTORY FIVE RACING, INC. IS PROHIBITED.

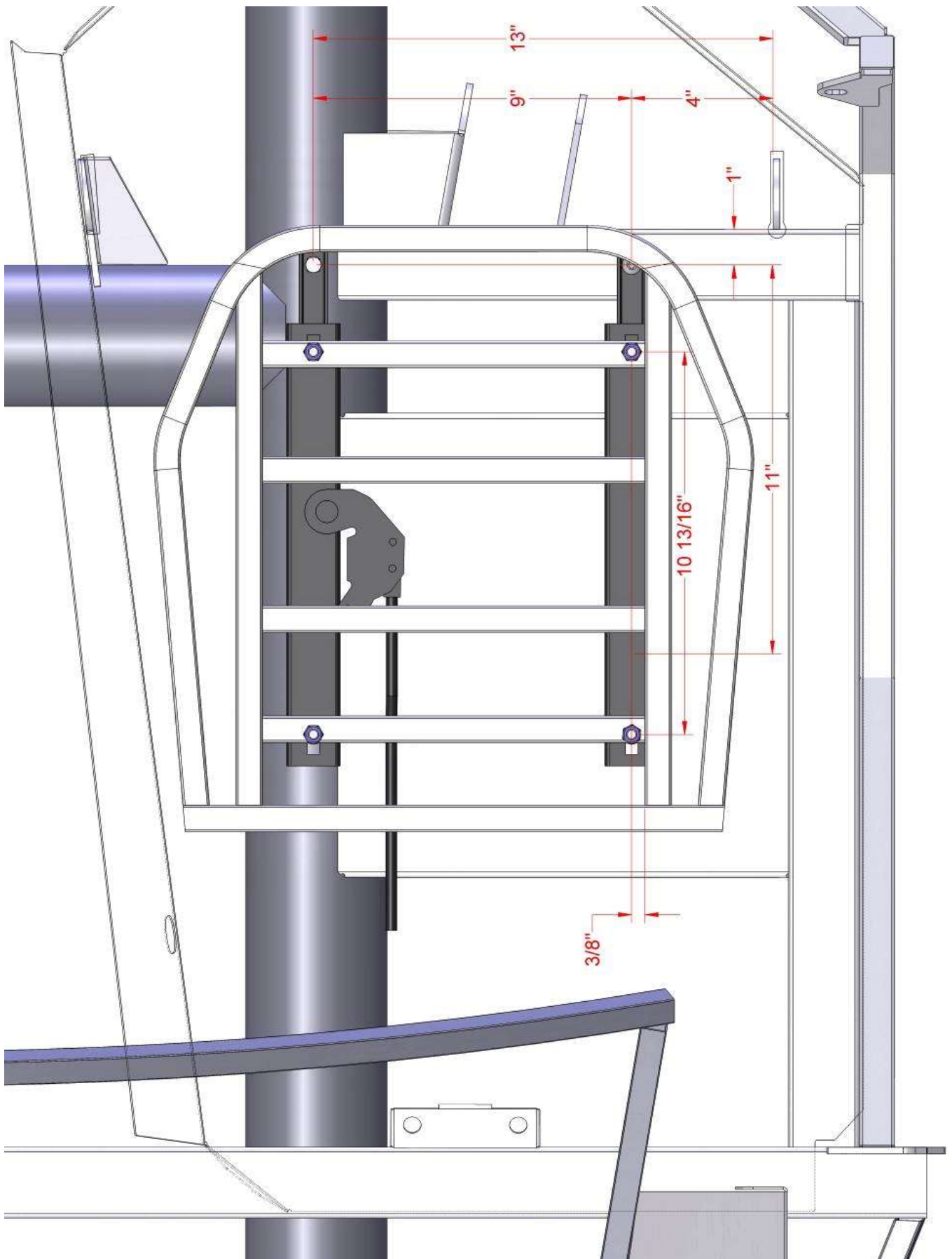

Draw a line on the drivers floor 1" forward from the outer seat harness mount and 13" towards the inside of the car. This is the middle of the 4" round tube which touches the aluminum floor panel and the inner rear seat track mount.

From the outer seat belt mount. Measure 4" in along the line just made. This is the location of the reare outer seat track mount.

The front holes for both tracks are  $10\frac{13}{16}$ " forward of the rear holes.

There are two ways to mount the inner seat track. Using the self tapping screws provided or bolts (not provided). If using bolts, be sure to use the right drill bit in order to tap the holes for the 4" round tube properly. If using the supplied screws, drill  $\frac{3}{16}$ " holes at the inner track locations marked.

Use a  $\frac{5}{16}$ " bit for the outer track hole locations.

On the seat tracks, insert the  $\frac{5}{16}$ " x 1.50" screws through the holes in the seat tracks so that they point up. Use the  $\frac{5}{16}$ " nuts, without the nylon lock, on the top side of the track and tighten them. For the front rectangular hole, locate the bolt so that it is  $10\frac{13}{16}$ " forward of the rear bolt.

Mount the inside seat track (has the locking handle) using the 1.50" screws and a  $\frac{3}{8}$ " socket.

Mount the outer seat track (non-locking) using the  $\frac{5}{16}$ " x 1" screw provided, and one of the bolts included with the seats in the rear as shown in the picture at the beginning.

Flip the seat bottom forward and mark the seat frame for the track mounting holes using the diagram on the previous page:

Front holes – as forward as possible on the second tube from the front,  $\frac{3}{8}$ " in from the front to back tube and 9" over from that.

Rear holes –  $10\frac{13}{16}$ " back from the front hole locations.

Using a  $\frac{5}{16}$ " drill bit, drill through seat frame.

Place the seat on the seat tracks and fasten using the four  $\frac{5}{16}$ " lock nuts.

Flip the seat back down.

Remove the jack stands using a floor jack.

## Hot Rod Instructions

Remove the rear studs from the tracks if so equipped. They are not used in our application.

Mark the front bolt location in the rectangular hole on top of the seat tracks (wide side)  $10\frac{13}{16}$ " from the center of the rear square hole.

Jack the left side of the car up and place on jack stands.

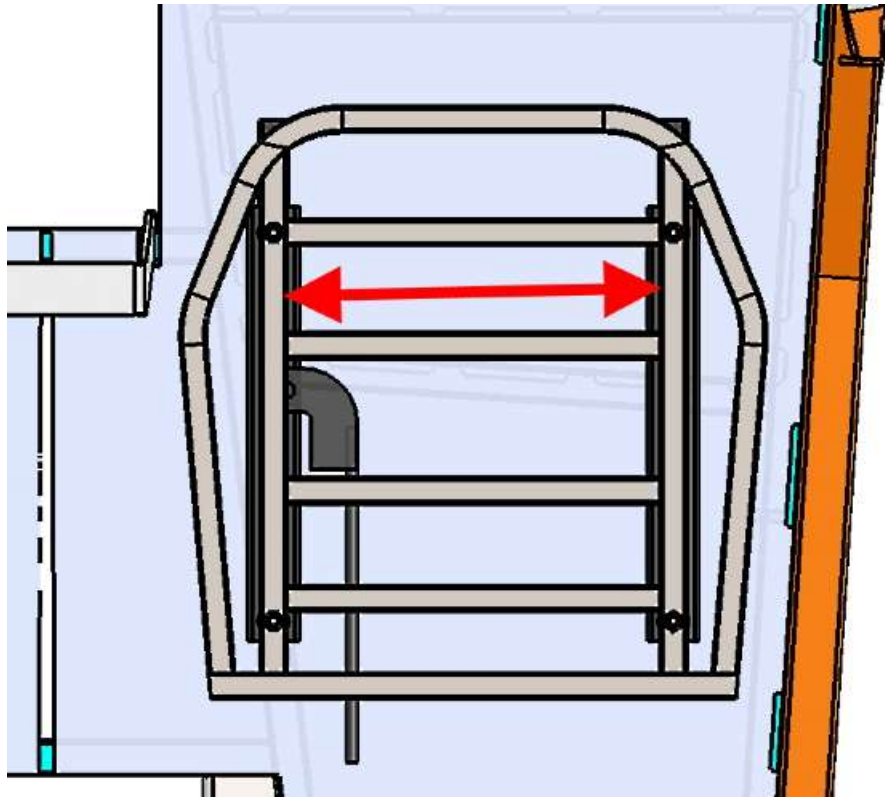

Look at the bottom of the seat and measure between the tubes that the seat track will mount on. The measurement should be  $11\frac{9}{16}$ " to the center of the tubes. If not, the measurements in the picture below, to the seat belt mount and between the tracks should be adjusted.

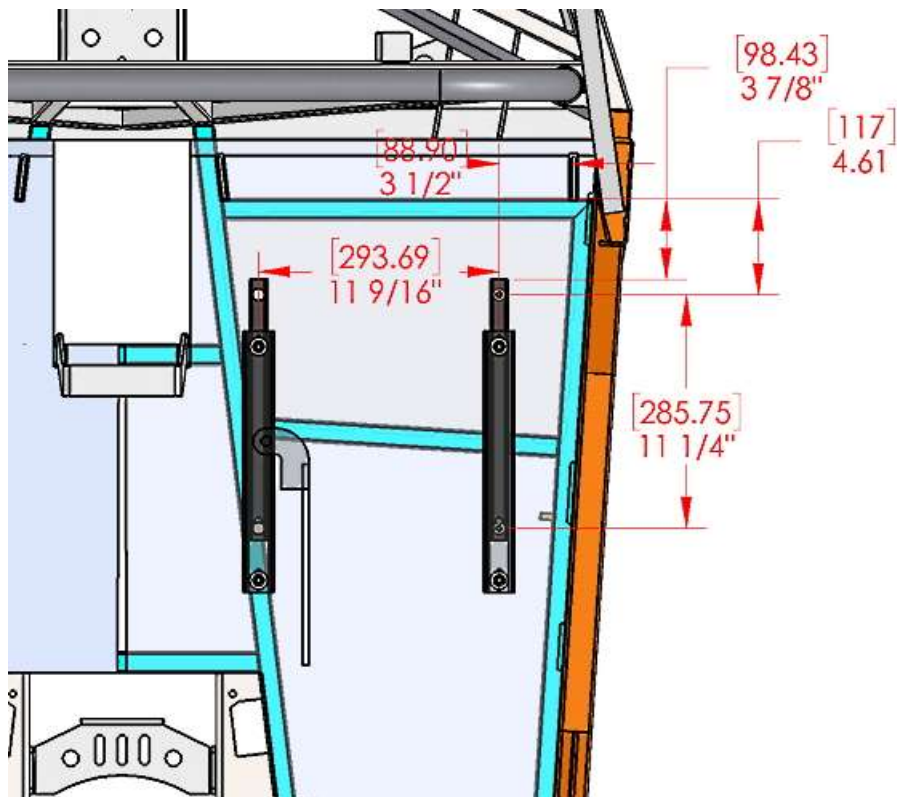

Use the diagram above to locate the rear holes on the cockpit floor  
Use a  $\frac{5}{16}$ " bit to drill the track hole locations.

On the seat tracks, insert the  $\frac{5}{16}$ " x 1.50" screws through the holes in the seat tracks so that they point up. Use the  $\frac{5}{16}$ " nuts, without the nylon lock, on the top side of the track and tighten them. Use the supplied bolts or the kit supplied seat mount bolts for the rear track to frame bolts. Use the kit supplied washers and lock nuts for the two front track studs.

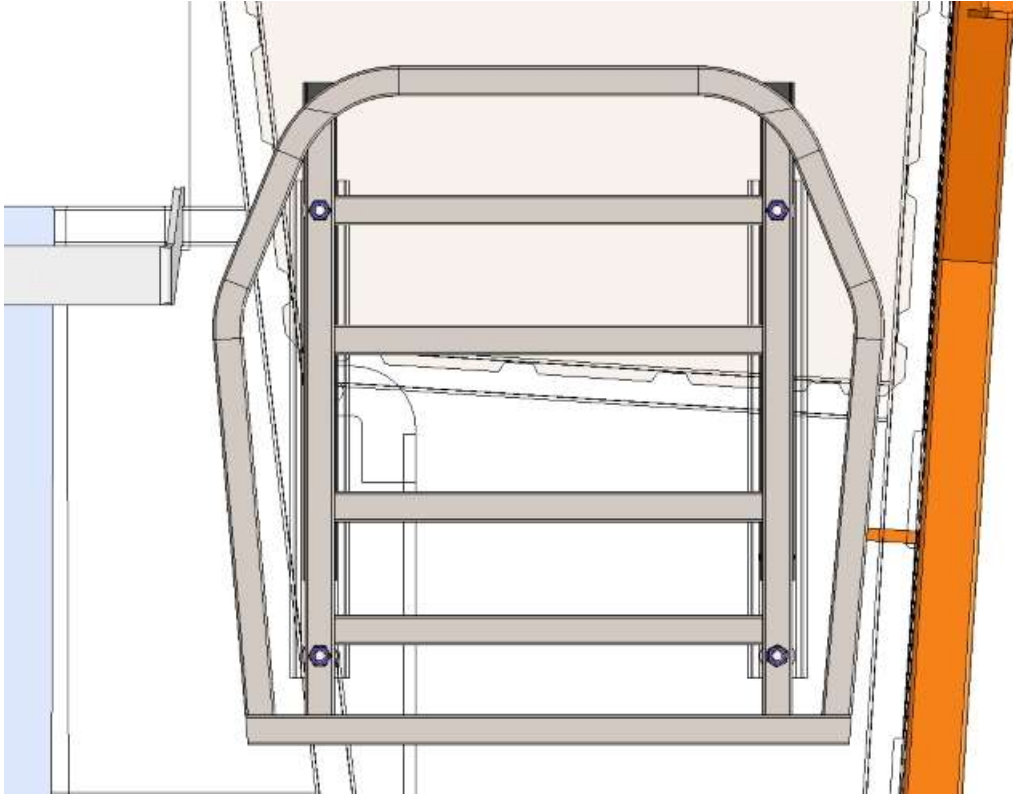

Mark the seat frame for the track mounting holes, the rear holes should be centered on the vertical and horizontal tubes. The front holes should be 11.25" forward of the rear holes. If the tube distance measured earlier was different, modify the locations accordingly.

Using a  $\frac{5}{16}$ " drill bit, drill through seat frame.

Place the seat on the seat tracks and fasten using the four  $\frac{5}{16}$ " lock nuts.

Flip the seat back down.

Remove the jack stands using a floor jack.