



Chassis Wiring Harness

INSTALLATION INSTRUCTIONS

ROADSTER, COUPE AND HOT ROD



REVISION W, NOVEMBER 2019

© 2019 Factory Five Racing Inc.
9 Tow Rd
Wareham, MA 02571
Phone 508.291.3443 • Fax 508.291.3883

Table of Contents

| | |
|--|-----------|
| Safety Notice..... | 1 |
| Safety Tips | 2 |
| How to use This Book | 3 |
| What You Get..... | 3 |
| Parts Included | 4 |
| Tools Needed..... | 7 |
| Pre-installation Information..... | 8 |
| Wiring Harness Layout | 9 |
| Chassis prep | 10 |
| Installation Instructions | 12 |
| Main Harness | 12 |
| Fuse Panel mount | 12 |
| Steering Column connector | 18 |
| Inertia switch | 19 |
| Harness Ground..... | 19 |
| Brake switch..... | 20 |
| Clutch safety Switch..... | 20 |
| Carbureted Engine | 21 |
| Fuel Injected Engine | 21 |
| Starter Solenoid | 22 |
| Alternator..... | 22 |
| Ignition Switch | 23 |
| Headlight switch | 28 |
| Heater..... | 28 |
| Radio | 28 |
| Wiper | 28 |
| Underdash/Courtesy light..... | 28 |
| Rear harness..... | 30 |
| Harness Diagrams | 32 |
| Fuel connectors..... | 39 |
| License Plate Wiring | 40 |
| Taillights | 41 |
| Gauge Sending Unit Harness..... | 41 |
| Electric Fan | 44 |
| Engine controlled fan | 44 |
| Thermostat switch control | 45 |
| Front Harness | 46 |
| Headlights/Turn signals..... | 50 |
| Electric Fan | 50 |
| Dash Harness/Gauges | 50 |
| Autometer gauge install | 51 |
| GPS Vintage gauge install | 60 |
| Troubleshooting | 67 |

Safety Notice

While there are many things to love and be proud of in our country today there are a few things that we wish were different. With regret and a small amount of resentment we include the following warning and statement of non-liability at the advice of men with soft hands and necks the size of pencils.

The procedures and recommendations contained in this book are to be used as a guide with the ultimate determination of safe construction to be made by you. If you feel uneasy about whether you have the skills to wire your own vehicle, **DO NOT PROCEED**. This project involves dealing with electrical connections for a vehicle. It is intended for individuals who have the skills and abilities commensurate with the scope of a project of this magnitude.

This kit is only a collection of parts designed for use primarily as a race car. You are responsible for ensuring that the vehicle you build complies with all Federal, State and local laws regarding its use. Except as may be specified in writing, Factory Five makes no warranties, expressed or implied, on the products (parts, or kits) offered for sale. All implied warranties of merchantability and fitness for a particular purpose are expressly disclaimed by Factory Five.

While Factory Five products are thoroughly tested under actual race conditions, Factory Five cannot control the quality of the installation or application of these products. The products offered for sale are true race car components, the installment of which often requires considerable time and fabrication skill. Before attempting any installation or assembly, the purchaser should determine the suitability of the product for the intended use, the time, and level of skill necessary for correct installation or assembly.

Factory Five does not make any warranty, expressed or implied. Purchaser expressly **ASSUMES THE RISK** of all personal, property and economic injury, damage or loss, either direct or indirect, arising from the use, misuse, or failure to determine the appropriate use of any Factory Five product.

Ford and Chevrolet, GM and Cobra are registered trademarks.
Factory Five Racing, Inc. is not connected to the holders of these marks.



Safety Tips

- Read the manual. It is a good guide and place to start.
- Don't take short cuts.
- Before starting work, make sure you have the proper tools, the required parts, and sufficient space for the job. If you damage any parts, it will probably be because they were either not stored properly or, the wrong tool was used to install them.
- Don't work when you're too tired or upset. The car you will be building is capable of supercar levels of performance, and your life depends on the quality of your workmanship.
- Never work under a raised car unless it is well supported by stands intended for that purpose. Never work under a car supported by a jack.
- Always observe good safety practices such as the use of eye protection, protective clothing, and gloves.
- Keep the battery disconnected whenever you work on fuel or electrical systems and always keep a fire extinguisher handy.
- Don't allow children in the work area.
- Partially assembled cars attract a crowd. Keep garage doors closed or mark off work areas.
- Make sure that all electrical equipment is grounded.
- If working alone, have someone check on you periodically.
- Work in a well-ventilated and well-lighted area.
- Use portable safety lights for under-carriage work. Never use an exposed bulb type light.
- Clean your build area after each assembly is completed. This will speed your build process as it ensures that you know where your tools are and prevents tripping injuries.
- It is impossible to anticipate all of the possible hazards. Care and Common Sense will prevent most accidents

How to use This Book

This Assembly manual is intended to help you wire your Factory Five Kit. This book will not explain such things as radio or power window installations. A secondary purpose of this book is to use it as reference for owners that want to do maintenance work on their cars or for those that purchase finished cars, to understand their cars better.

This manual was written with the average weekend mechanic in mind. It is best to follow the manual step by step but if there is a part missing from the kit move to the next section and come back to it later when the part is available.

| I C O N K E Y | |
|---|----------------------|
|  | Valuable information |
|  | Tools needed |
|  | Parts Needed |

We have included an Icon key as the beginning of each section that contains useful information for each assembly that details the tools needed for that assembly, what assembly in the kit parts are packaged in that are needed for that step and any useful information or warnings.

What You Get

This chassis harness has been especially designed by Factory Five Racing for use in the Roadster, Coupe and Hot Rod. Designed to allow easy installation, each end of the loom wrapped harness is labeled with its location on the car. Step by step instructions including color wiring diagrams explain how and where to install the harness.

The fuse panel uses standard ATC blade type fuses and includes 11 fuses, 3 relays and 2 flashers. Wires routed to the correct locations have been included for wipers, heater and radio. A fuel inertia switch has been wired into the fuel pump circuit for added safety. A dash wiring harness has been included for wiring Autometer or other Factory Five gauges. The harness also has dedicated power wires if you plan on running fuel injected.

This is the ultimate chassis harness.

Parts Included

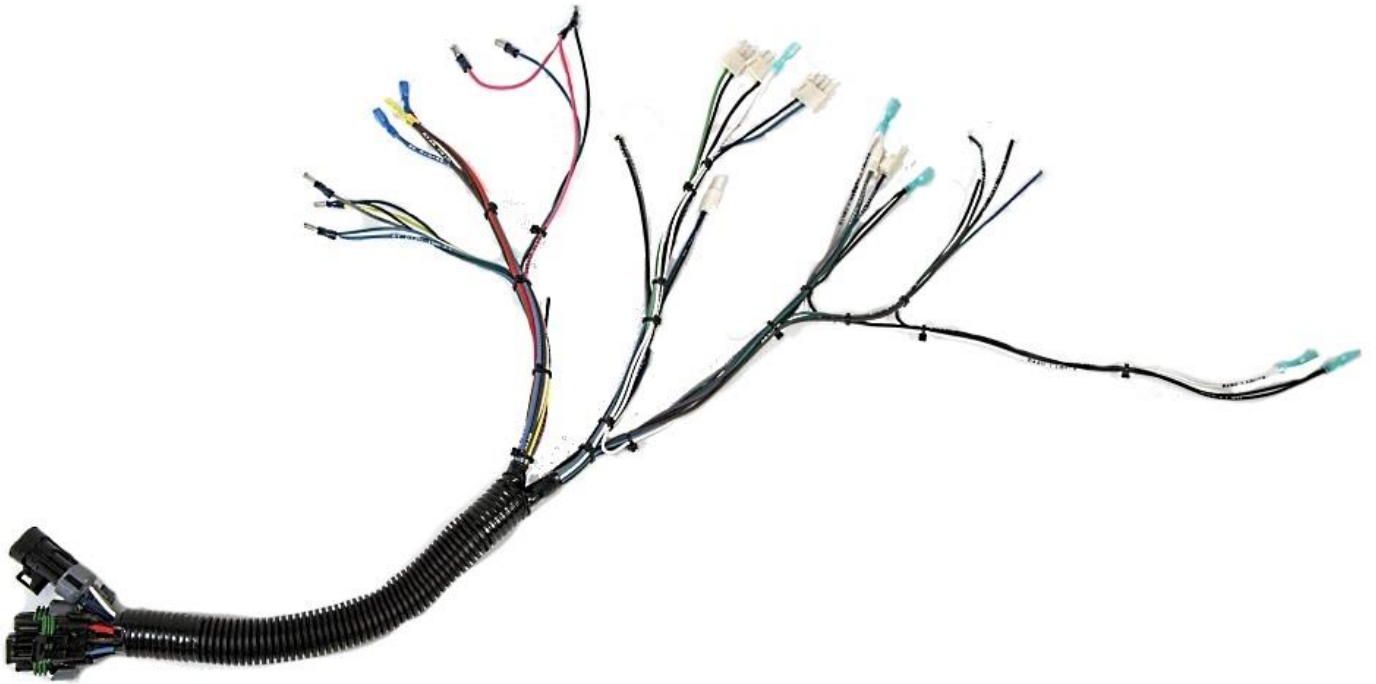

Dash Harness



Main fuse panel Harness



Front Harness



Rear Harness



Sending Unit Harness

Tools Needed

The following lists of the tools and supplies that are needed to build your kit. The “helpful” items are not crucial to the assembly but make life easier. Home Depot HUSKY®, Sears CRAFTSMAN®, and Snap-On® tools are all guaranteed for life and we’ve found them to be more reliable over discount tools.

Drill

Drill bits ($\frac{3}{32}$ ”, $\frac{1}{8}$ ”, $\frac{9}{64}$ ”, $\frac{3}{16}$ ”, $\frac{7}{32}$ ”, $\frac{5}{16}$ ”)

Razor knife

Wire stripper/crimping tool

Wire cutters

Electrical tape

Sandpaper

File with round side or round file

$\frac{1}{4}$ ” nut driver

$\frac{7}{16}$ ” wrench

$\frac{5}{32}$ ” hex key

$1\frac{1}{4}$ ” Hole saw

$\frac{1}{4}$ ” nut driver

Tin snips

Rivet tool

The thing between your ears



Pre-installation Information

- Read all of the instructions thoroughly before starting the actual installation. If you have any technical questions concerning this installation please call our tech department.
- For EFI connections please read the EFI section.
- Some aluminum pieces and other parts should already have been mounted on the frame. Some of these mounted pieces may not be shown in all of the pictures.
- Route the harness away from sharp edges, exhaust pipes and moving parts.
- Have all needed tools and connectors handy.
- When crimping wires, select the correct size crimper for the wire.
- The layout in these instructions is specific for the Roadster but the basic layout locations are the same for the Coupe and Hot Rod. See the Hot Rod assembly manual for more routing instructions.

Wiring Harness Layout

| | | | |
|---|---------------------------------|----|--------------------------|
| 1 | Passenger headlight/turn signal | 10 | Fuel level plug |
| 2 | Driver headlight/turn signal | 11 | License plate light |
| 3 | Brake Switch | 12 | Fuel pump plug |
| 4 | Clutch safety wires | 13 | Passenger tail lights |
| 5 | Inertia Switch | 14 | Radio/Heater/Wiper wires |
| 6 | Headlight Switch | 15 | Gauge sending unit wires |
| 7 | Ignition Switch | 16 | Alternator plug |
| 8 | Dash/Gauge plugs | 17 | Electric fan plug |
| 9 | Driver Tail lights | 18 | Fuse panel |
| | | 19 | EFI power/Coil wires |

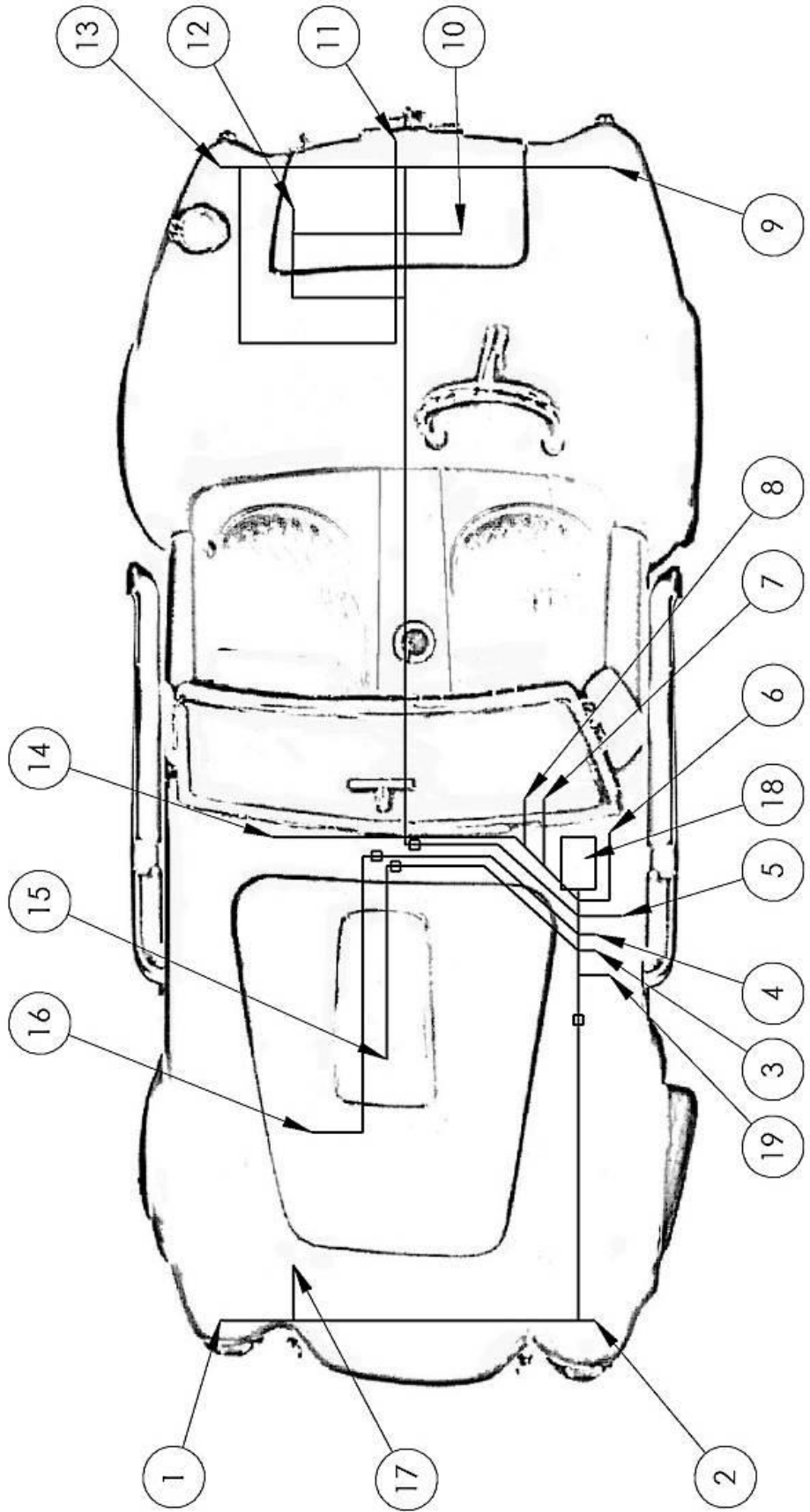

Chassis prep

✂ Marker, tape measure, 1.25" hole saw, drill.



From the opening in the firewall, measure over and mark the firewall 14.75".



Measure and mark the firewall 1.50" up.



Measure left from the first point and mark the firewall at 2.50" and 5.00" so there are three marks altogether.



If running a Fuel injection harness, three holes would need to be drilled.



Decide which hole location the EFI harness will use. The chassis harness is pretty flexible on location so any location can be used for it.



Check the hole size needed for the EFI harness grommet before drilling any holes.



If running a Coyote engine the right location is best.



Drill the two chassis harness holes on the desired points using a 1.25” hole saw.

Installation Instructions

Main Harness

- ✂ $\frac{7}{16}$ ” wrench, $\frac{5}{32}$ ” hex key, sandpaper.
- 🔧 Fuse panel harness, aluminum fuse panel mount, $\frac{1}{4}$ ” x 1” flange screws, $\frac{1}{4}$ ” locknuts, #14 x $\frac{1}{2}$ ” screw, #6 self tapping screws from kit.

FUSE PANEL MOUNT

Locate the main harness which has the fuse panel. Remove the two flashers from the panel.

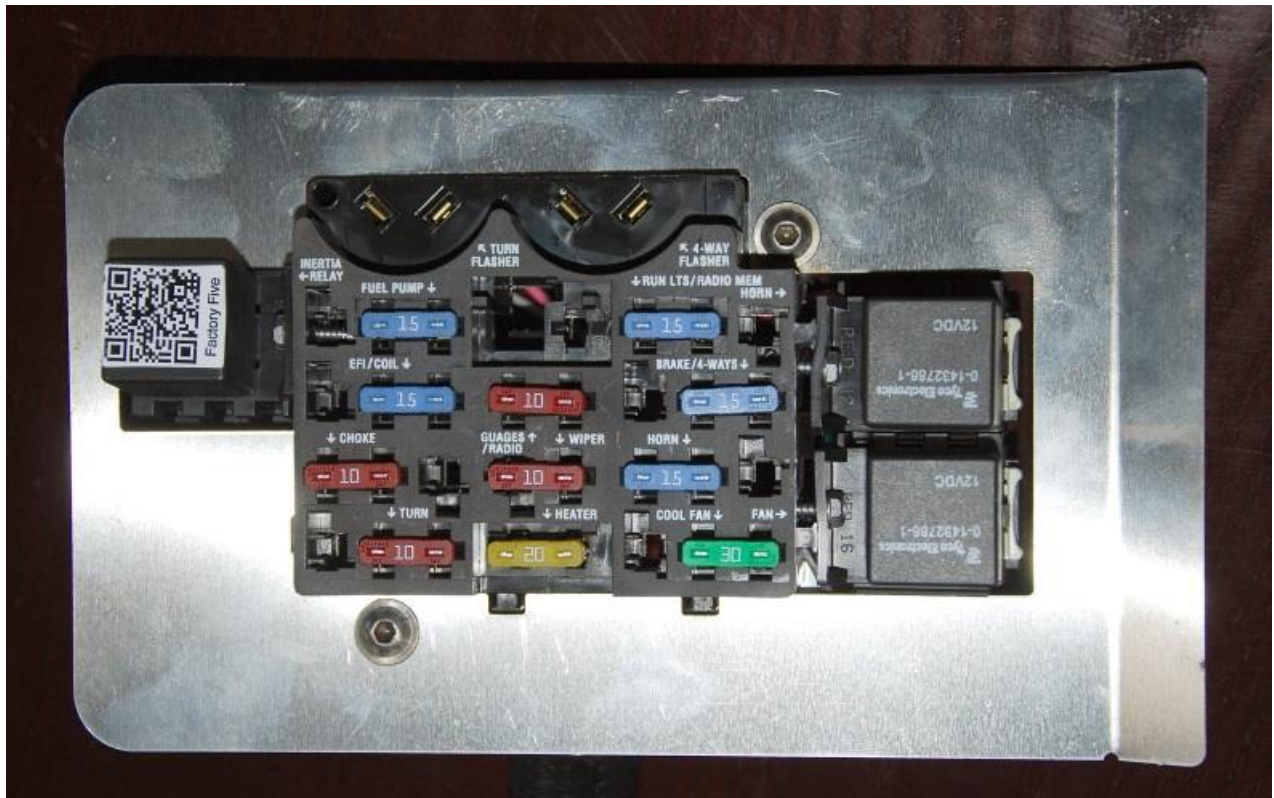

Attach the fuse panel mount to the fuse panel using the 1/4" screws and locknuts included.

Attach the LED flashers provided in the kit, the wire coming off the flashers will need to be grounded.

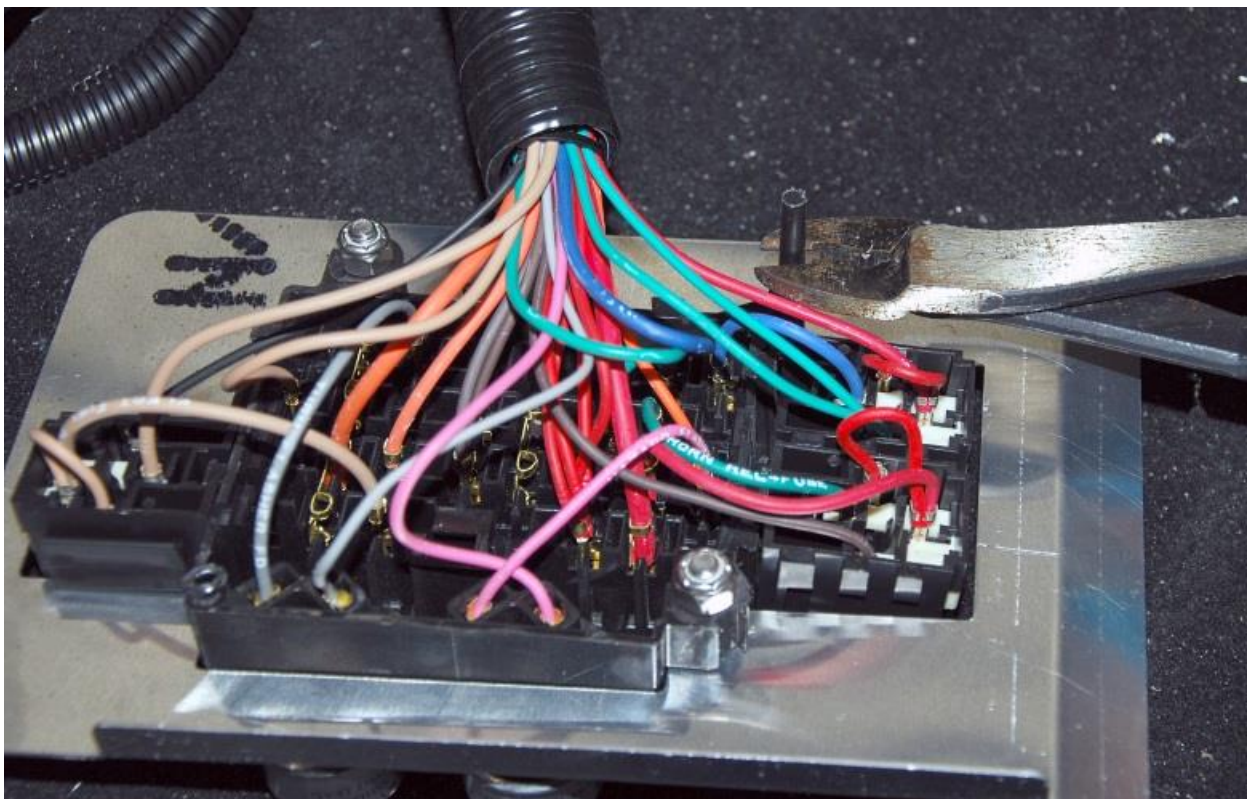
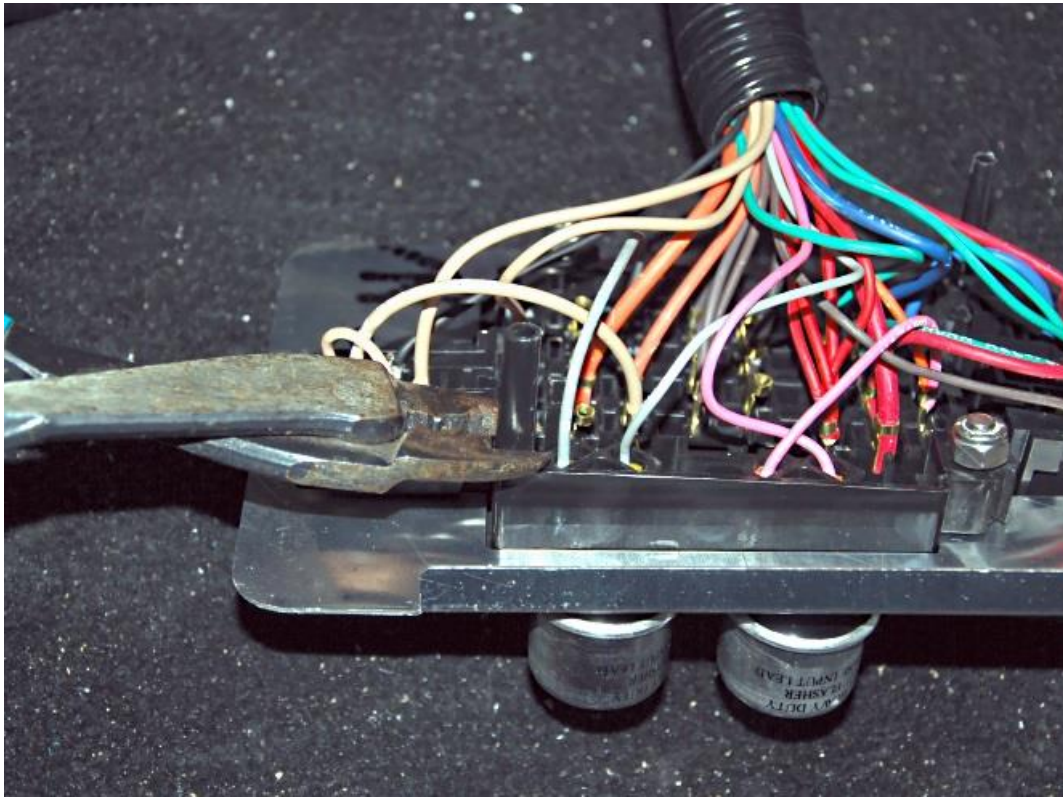

If not cut, use a pair of wire cutters to cut the two plastic tubes sticking up from the fuse panel.

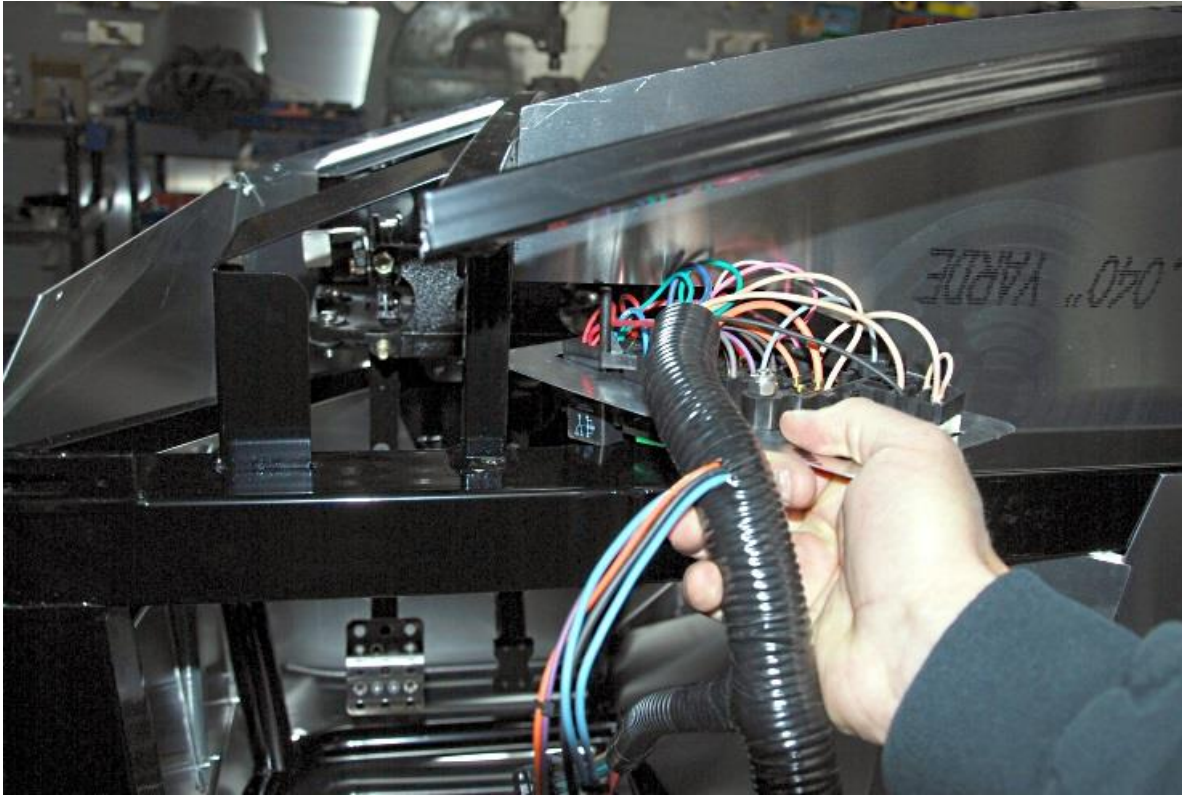

From inside the cockpit, push the fuse panel through the large opening in the firewall into the footbox.

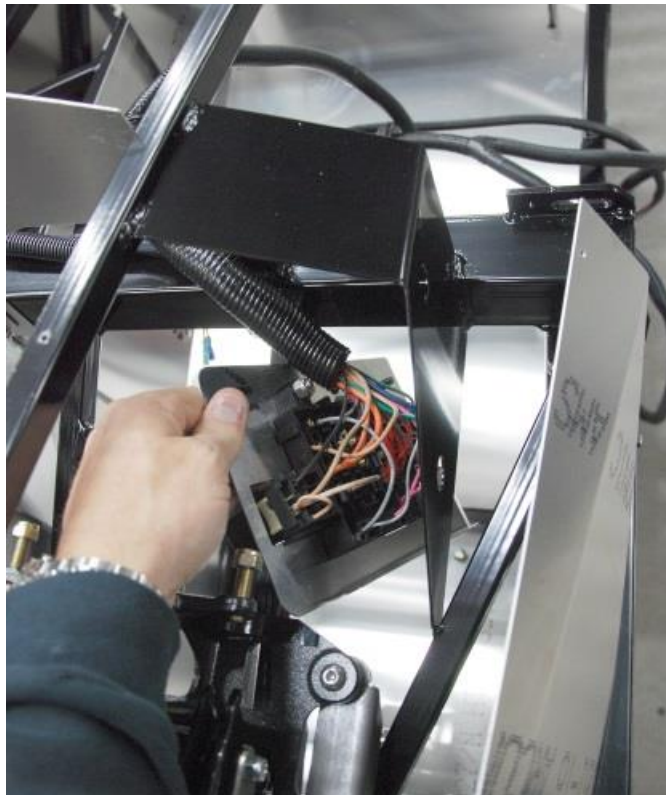

Push the fuse panel down between the windshield mounting bracket and the $\frac{3}{4}$ " pedalbox mounting tube.

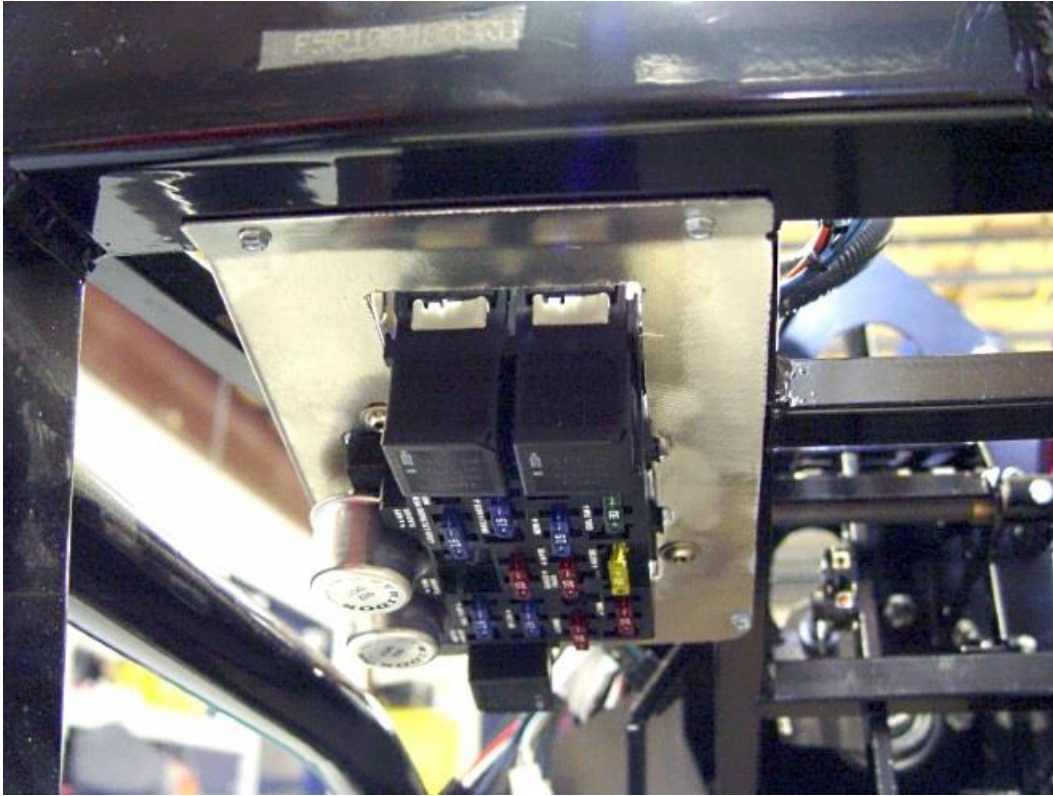

Attach the fuse panel mount to the 2"x 2" tube and the 3/4" tube as shown below using the #6 self-tapping screws that originally attached the aluminum panels to the frame.



Pull the front harness plugs and the flat steering column connector (not used in the roadster) into the pedalbox area and put them on top of the pedal box.

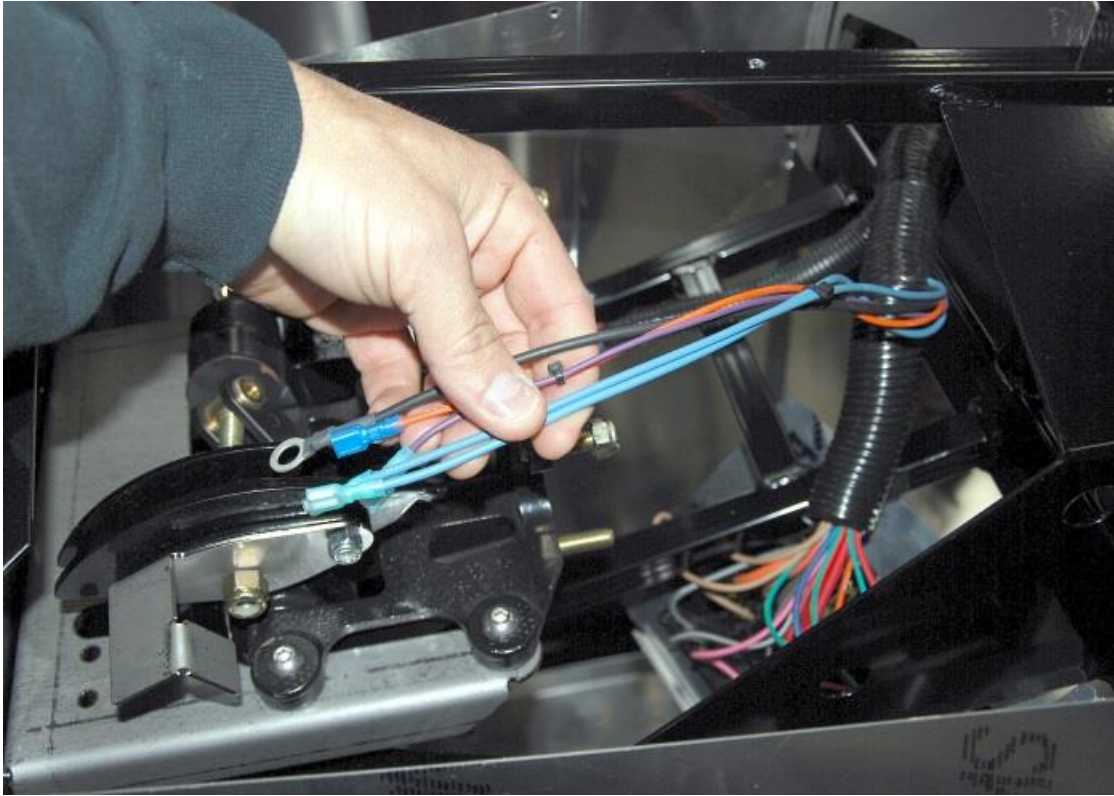

Pull the ground, brake pedal wires and neutral safety switch wires into the pedalbox area.

Run the remaining harness wires along the top of the 2"x 2" tube towards the right side of the frame.



Push the alternator and starter wires through the right hole in the firewall into the engine bay.



Work the grommet into the firewall hole.

STEERING COLUMN CONNECTOR



This is for use with the Hot Rod steering column only.

Refer to Hot Rod assembly manual instructions if connecting. Otherwise, do not use.

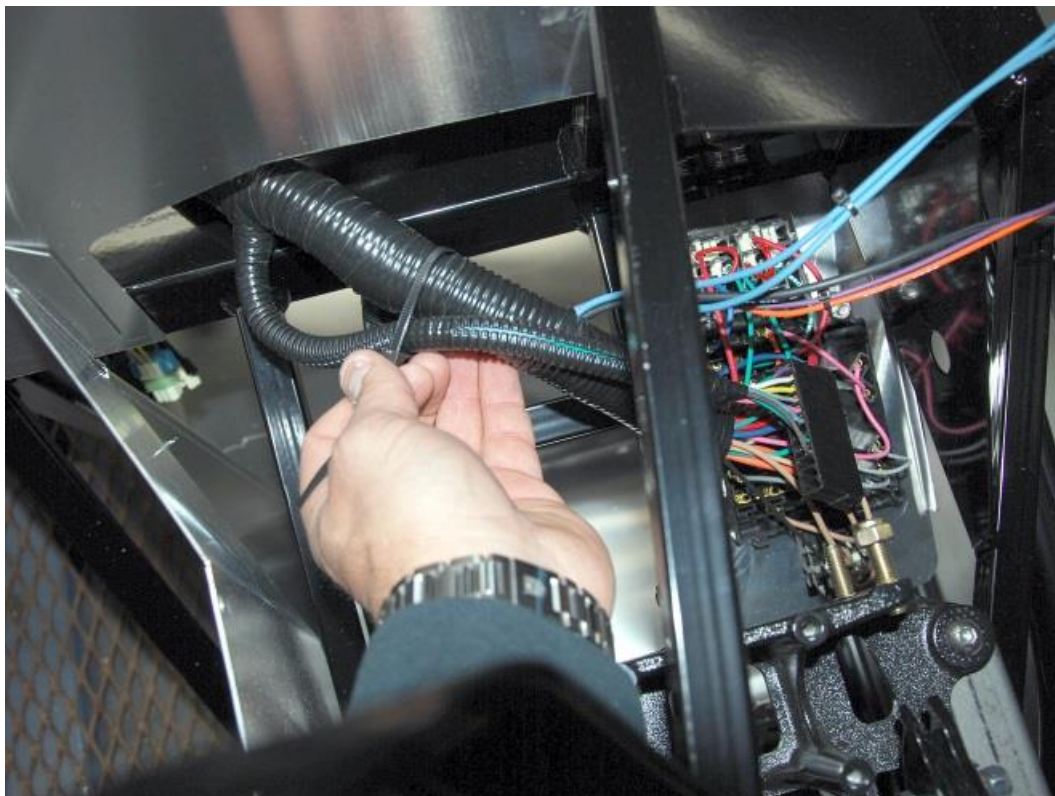

Zip tie the steering column connector back against the harness so that it will not rattle around.

INERTIA SWITCH



Do not mount the switch over the stamped chassis numbers.



Mount the fuel inertia switch to the right of the steering bearing mount using the self-tapping screws provided with the harness.

Push the inertia switch down to make sure it is “ON”

HARNESS GROUND



Make sure that any coating on the frame is removed before attaching grounds so that a good contact is made.

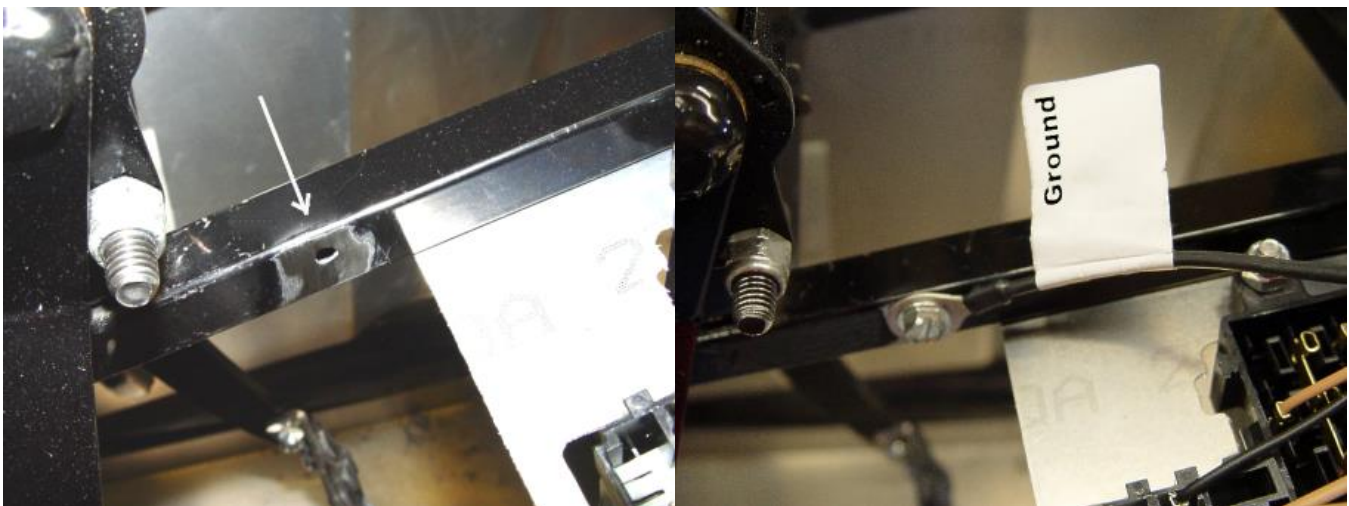

Frame coating ground off.

Ground wire attached.

Attach the ground wire near the fuse panel to the frame. Either drill a hole, remove any frame coating from the area and screw the ground in or, place the ground between the frame and the pedalbox and attach the pedalbox bolt.

BRAKE SWITCH

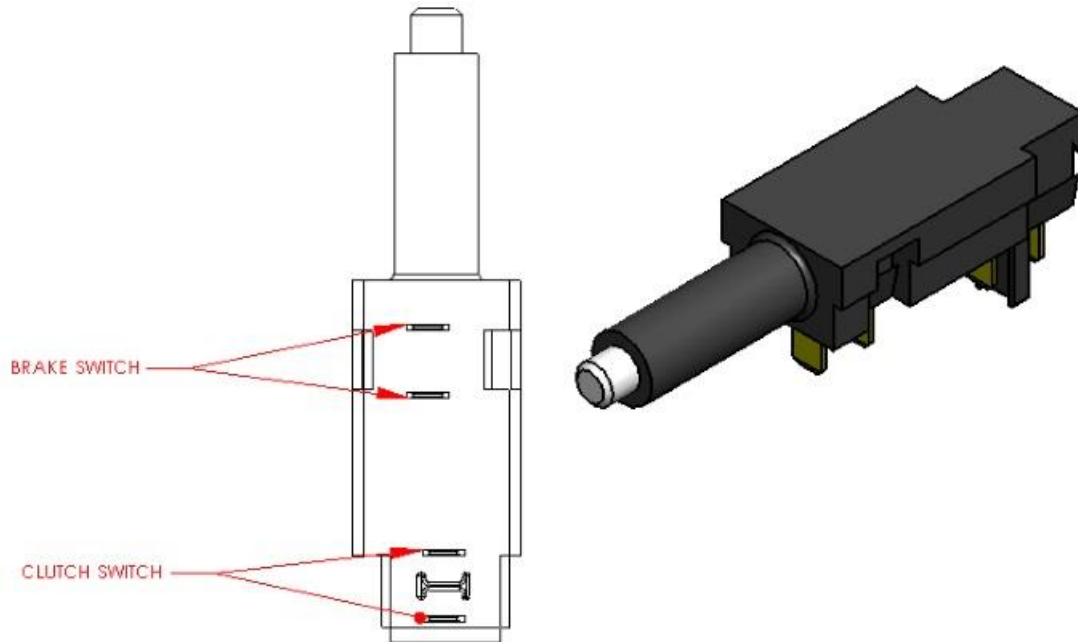

Push the orange wire onto one of the spades on the brake pedal switch. Push the purple wire onto one of the spades on the brake pedal switch.

CLUTCH SAFETY SWITCH

- ✎ A clutch safety switch is used to prevent starting the car while in gear. It requires pushing the clutch pedal in while starting the car.
- ✎ Another option is to use a momentary dash switch that must be used at the same time as the key.

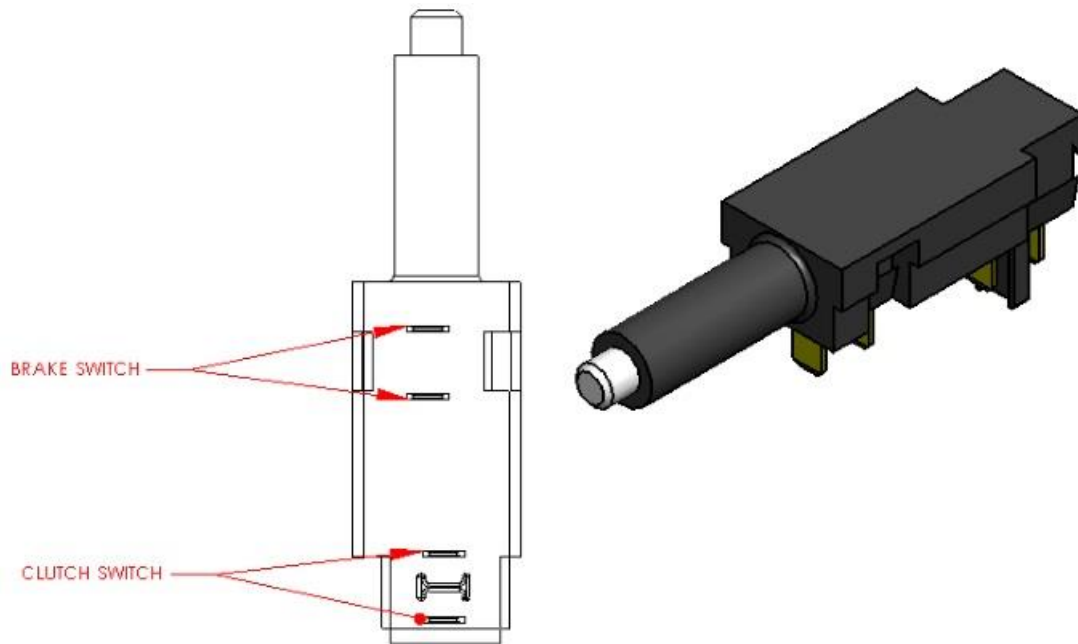

If a switch is not going to be used, connect the two wires together by either soldering the wires or using a butt connector from the “misc. electrical components” assembly in the Factory Five main kit pack.

CARBURETED ENGINE

Run the coil wires with the alternator wires and gauge sender wires for use with the coil.

FUEL INJECTED ENGINE



If running a Coyote Engine, refer to the Coyote Fitment instructions for Roadster, Coupe or Hot Rod.

Leave the coil and crank wires on the 2"x 2" tube and connect them to the power wires for the EFI harness according to the EFI harness instructions.

The COIL/EFI wire is a KEY ON - RUN POWER wire.

The EFI CRANK POWER wire is the START POWER wire

Connect the Speed sensor wires to the EFI wiring harness if needed.

Fuel pump wiring



The engine controlled fuel pump power can be used to control the relay in the chassis harness which would leave the fuse and relay easily accessible if necessary.

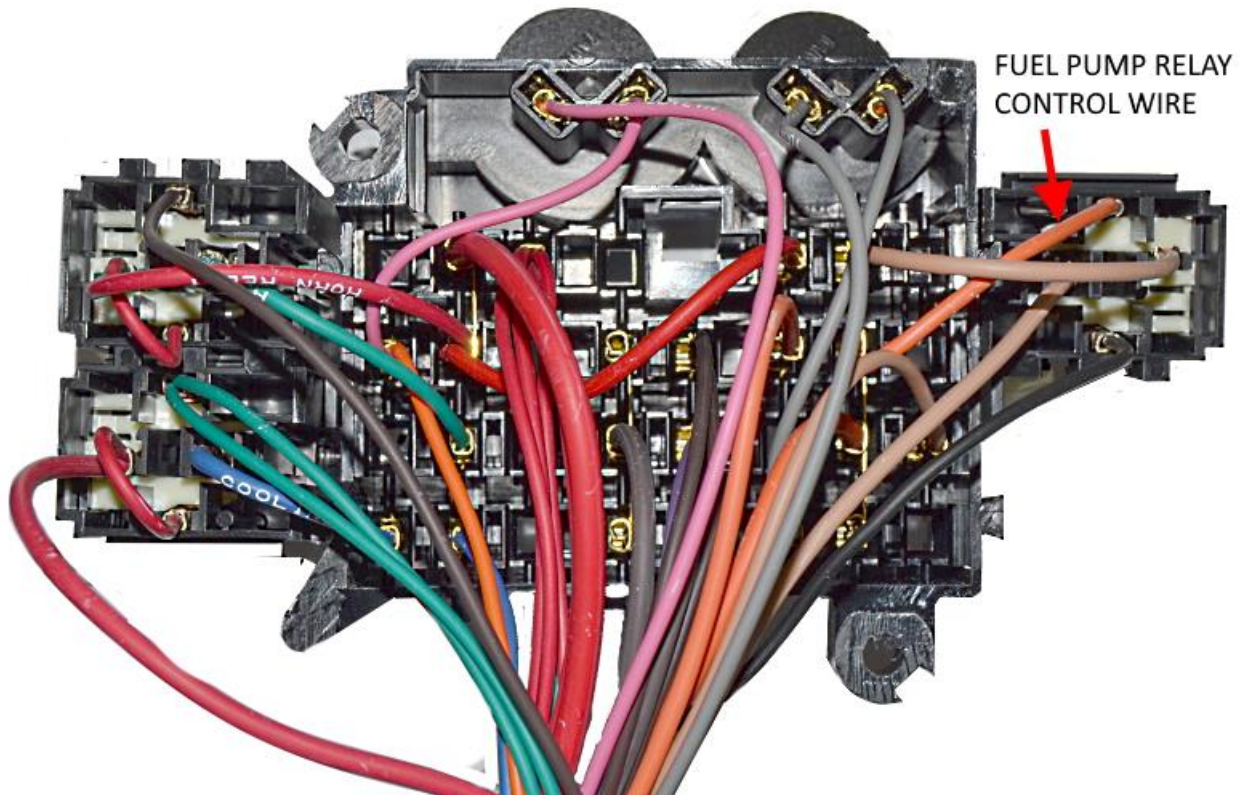

If the EFI harness uses its own wires for the fuel pump, cut the orange wire and connect the fuel pump wire from the EFI harness onto the orange wire going to the relay. This will use the EFI computer to turn the relay on/off.

The Inertia switch grounds the relay so this wiring still uses the inertia switch.

STARTER SOLENOID

Run the starter solenoid wires to the starter solenoid on the starter.

Connect the wires to the starter solenoid according to the wiring diagram.

ALTERNATOR

Run the alternator wires along the top of the engine to the alternator.

- ✎ If you are using a one-wire Alternator, attach the red wire ring to the post on the alternator. The brown wire is not used.
- ✎ If you are using a pushrod 5.0L EFI harness with the chassis harness, hooking up the Alternator ignition power (#22) is not necessary.

IGNITION SWITCH

- ✂ Needle nose pliers, round file, tin snips
- 🚗 Dash, ignition switch

Dash prep

Decide where on the dash the ignition switch will go, the Factory Five Roadster and Coupe cut dashes have a location set-up already with the cut shape if desired.

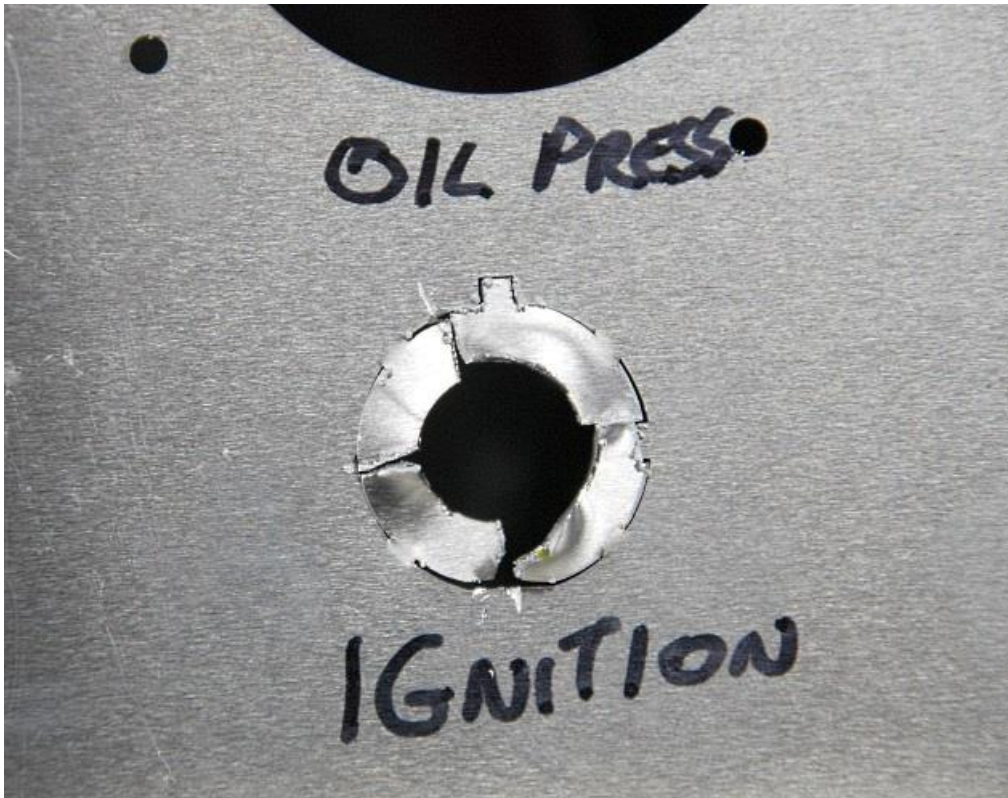

In order to install the ignition switch to fit the Factory Five laser cut hole correctly it is necessary to put one cut in the middle of each of the dashed cut sections.



Use a pair of needle nose pliers to bend the metal back and forth until it breaks.



Use a file to remove the burr left from the aluminum.



Test fit the switch in the hole.

Wiring

✂ Philips head screwdriver, electrical tape

Attach the ignition wires to the ignition switch using the wiring diagram as a guide for the correct posts for each wire.

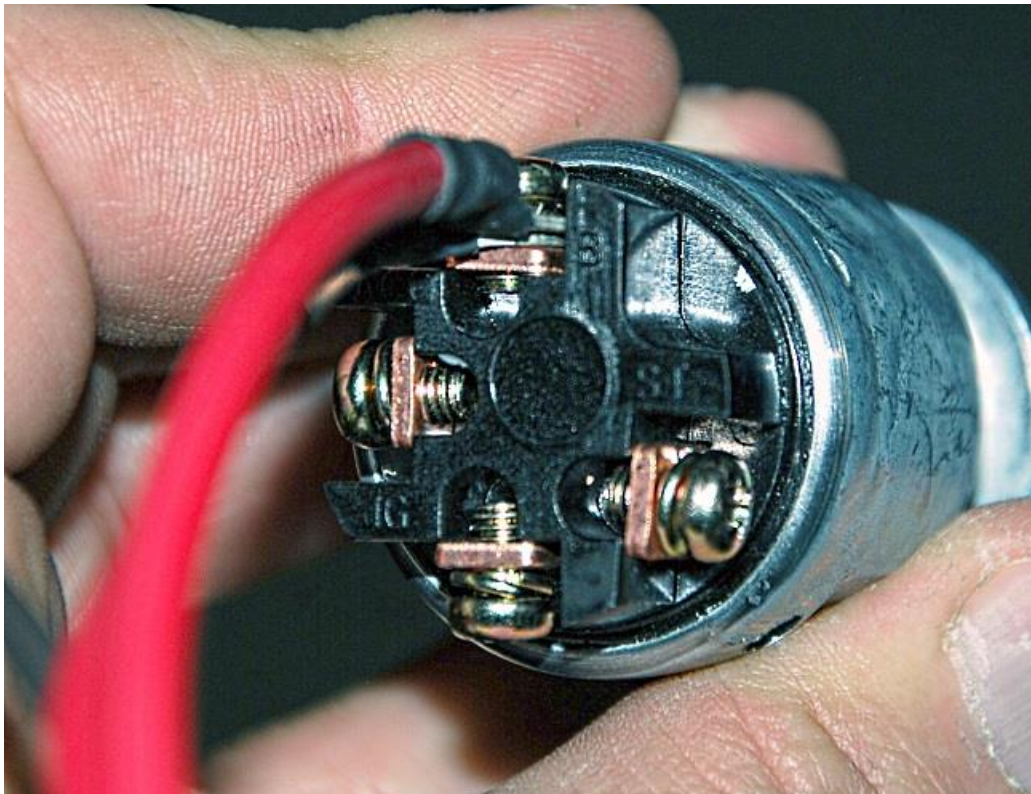

Connect the red wires to the “B” screw

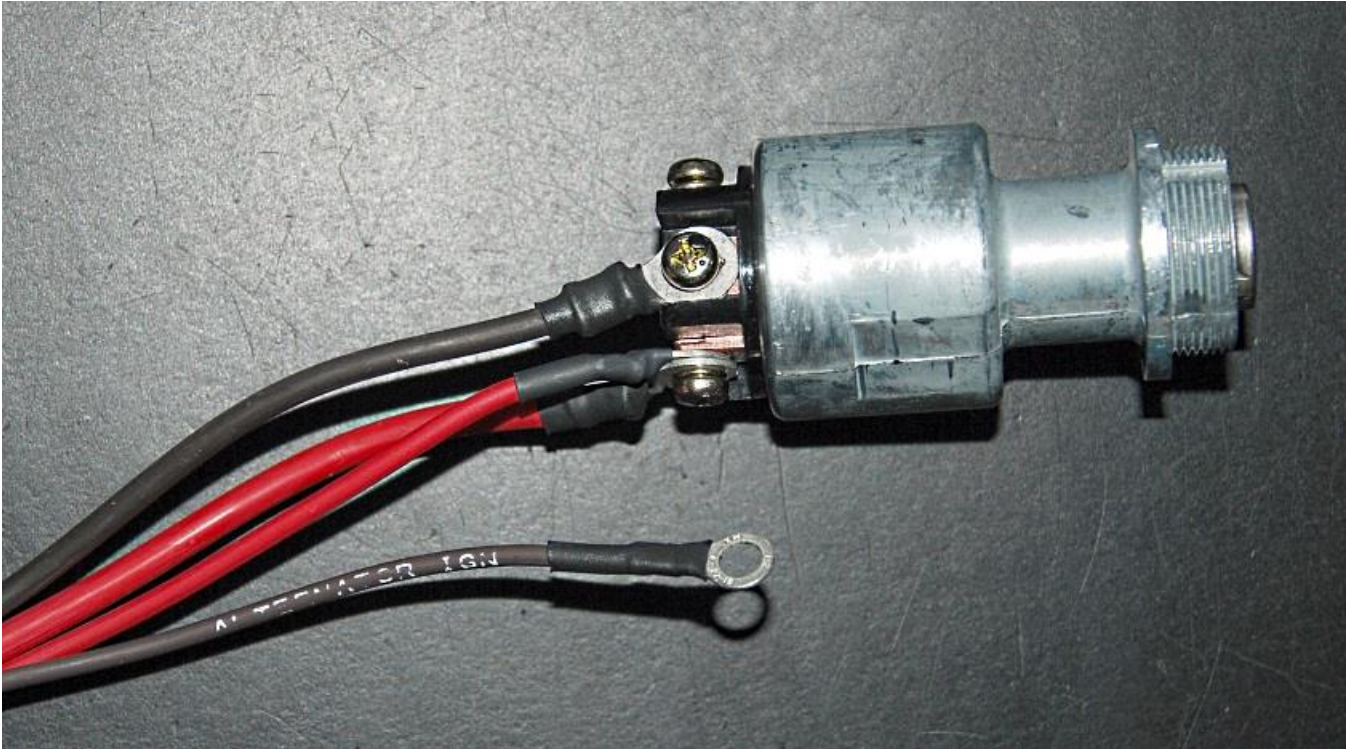

Connect the brown wires to the “ACC” screw. If running a 1-wire alternator, do not attach the brown “Alternator ign” wire, it is not used, zip tie or electrical tape the “Alternator ign” wire back against the harness.



Connect the orange wire to the “IG” screw.

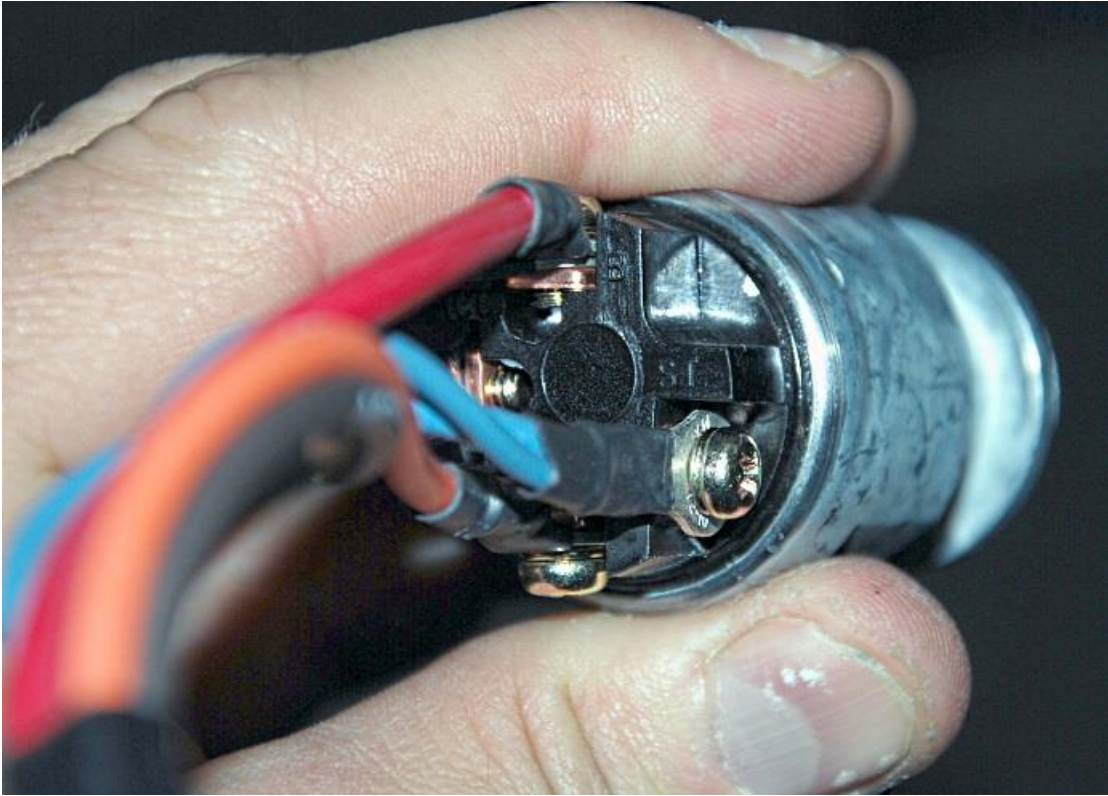

Connect the blue wires to the “ST” screw.



Wrap the screw end of the switch with electrical tape to avoid any accidental grounding.

HEADLIGHT SWITCH

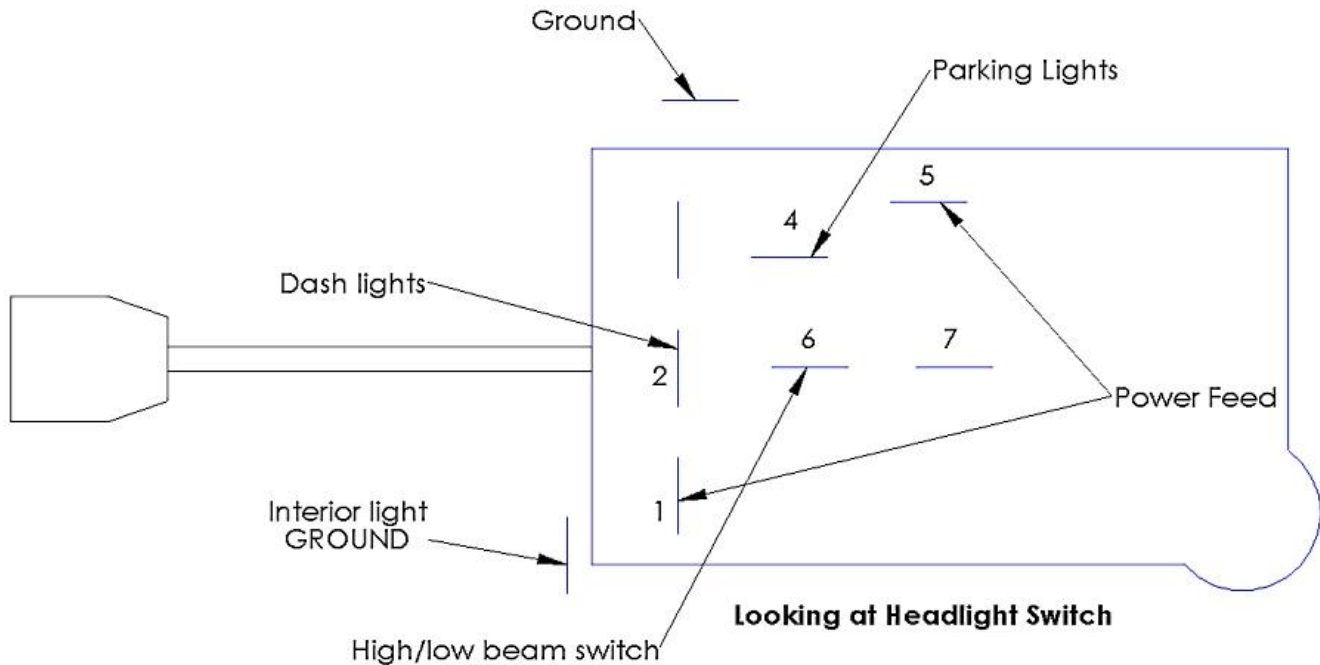

Attach the headlight switch to the main wiring harness plug.

HEATER

If used, connect the A/C or heater power wires that are run across the 2"x 2" tube to the A/C or heater.

RADIO

👉 This harness does not have any speaker wires or amplifier power wires in it.

If used, connect the correct power wires that are run across the 2"x 2" tube to the correct wires on a radio/amp.

WIPER

👉 The Factory Five wiper kits come with a switch and additional wires for the high, low, switched 12v and park functions of the wiper motor

If used, connect the power wires that are run across the 2"x 2" tube to the correct wires on the wiper motor.

UNDERDASH/COURTESY LIGHT

👉 The under dash/courtesy light provided in the complete kits and the Hot Rod can be cut into multiple pieces if lighting is desired in each footbox and under the dash.



How to cut the LED light strip

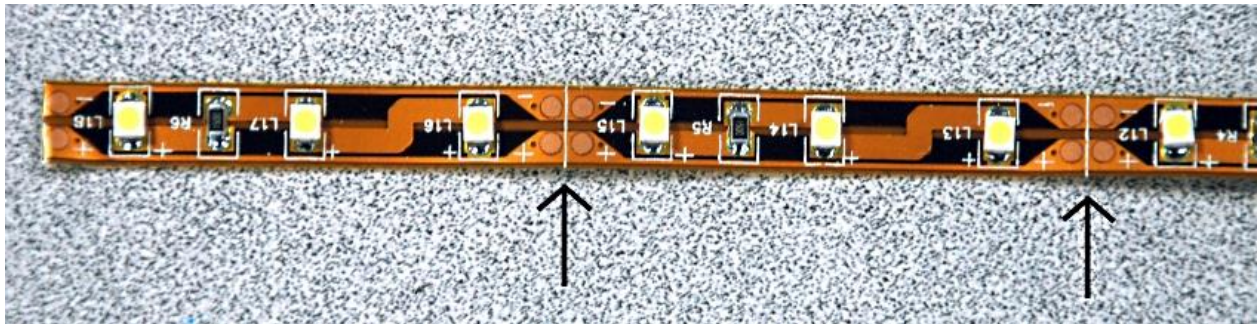

If you choose to cut and spread the lights around, wires will need to be soldered to each piece to connect them in series.

Wiring

Connect the red LED strip wire to the red courtesy light wire that is run across the 2"x 2" tube with the radio wires.

Attach the black ground LED strip wire to the gray headlight switch courtesy light ground wire.

When you twist the headlight switch knob counterclockwise all the way the light should turn on.

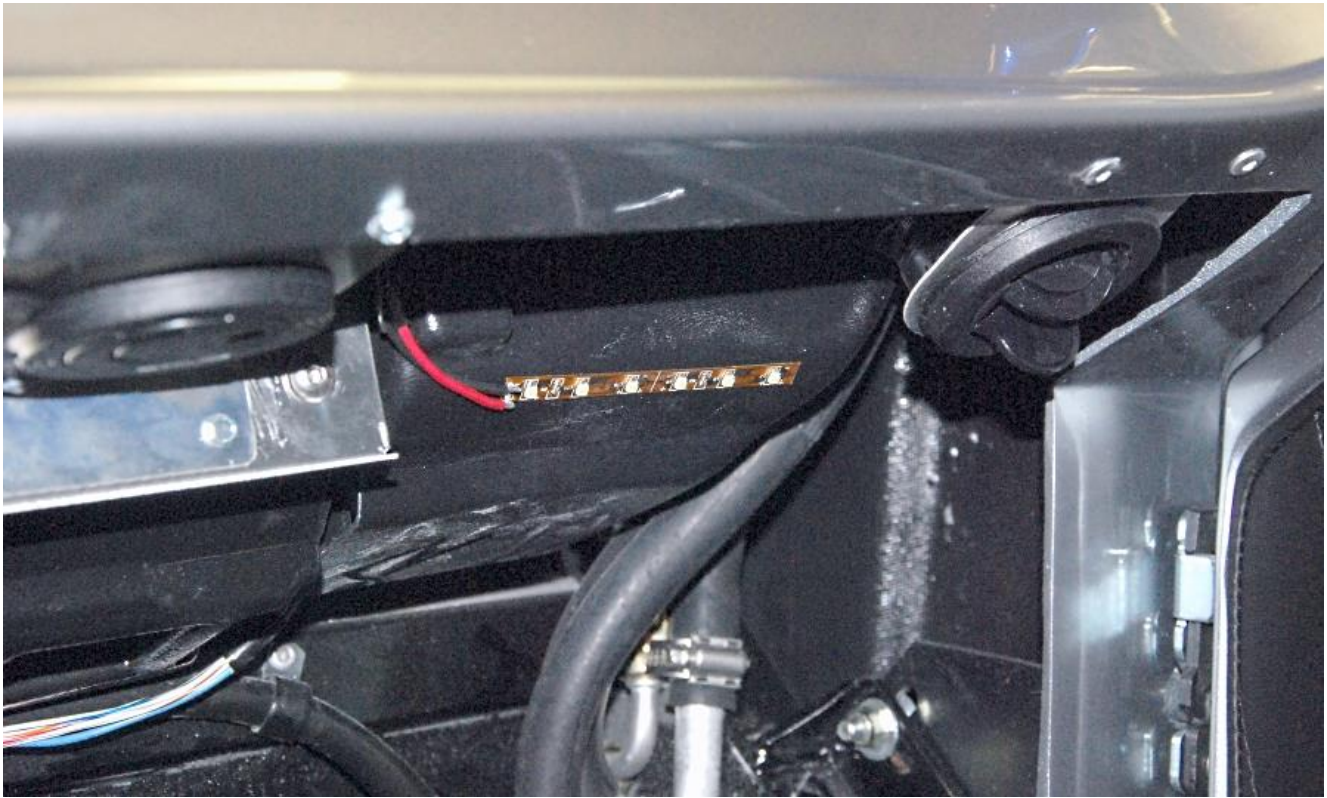

Attach the LED strip to the bottom of the dash or to the frame tube going across the cockpit.

Rear harness

Locate the rear harness.



From the engine bay side, push the two connectors through the hole in the firewall into the cockpit.



Work the grommet into the firewall hole.

Harness Diagrams



FACTORY FIVE RACING
ROADSTER, COUPE & HOT ROD
Rev T

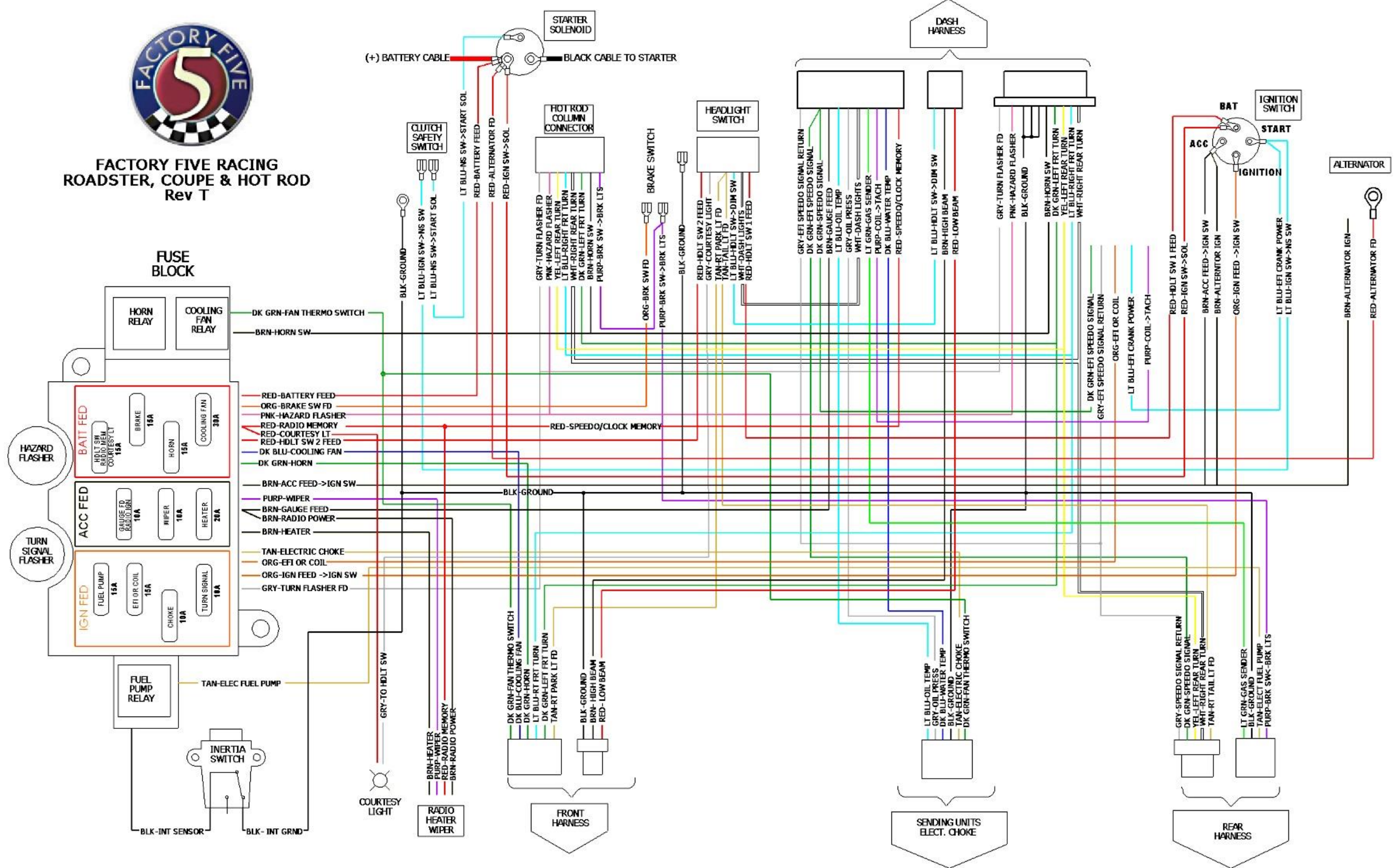



**FACTORY FIVE RACING
ROADSTER, COUPE, & HOT ROD
Rev T**

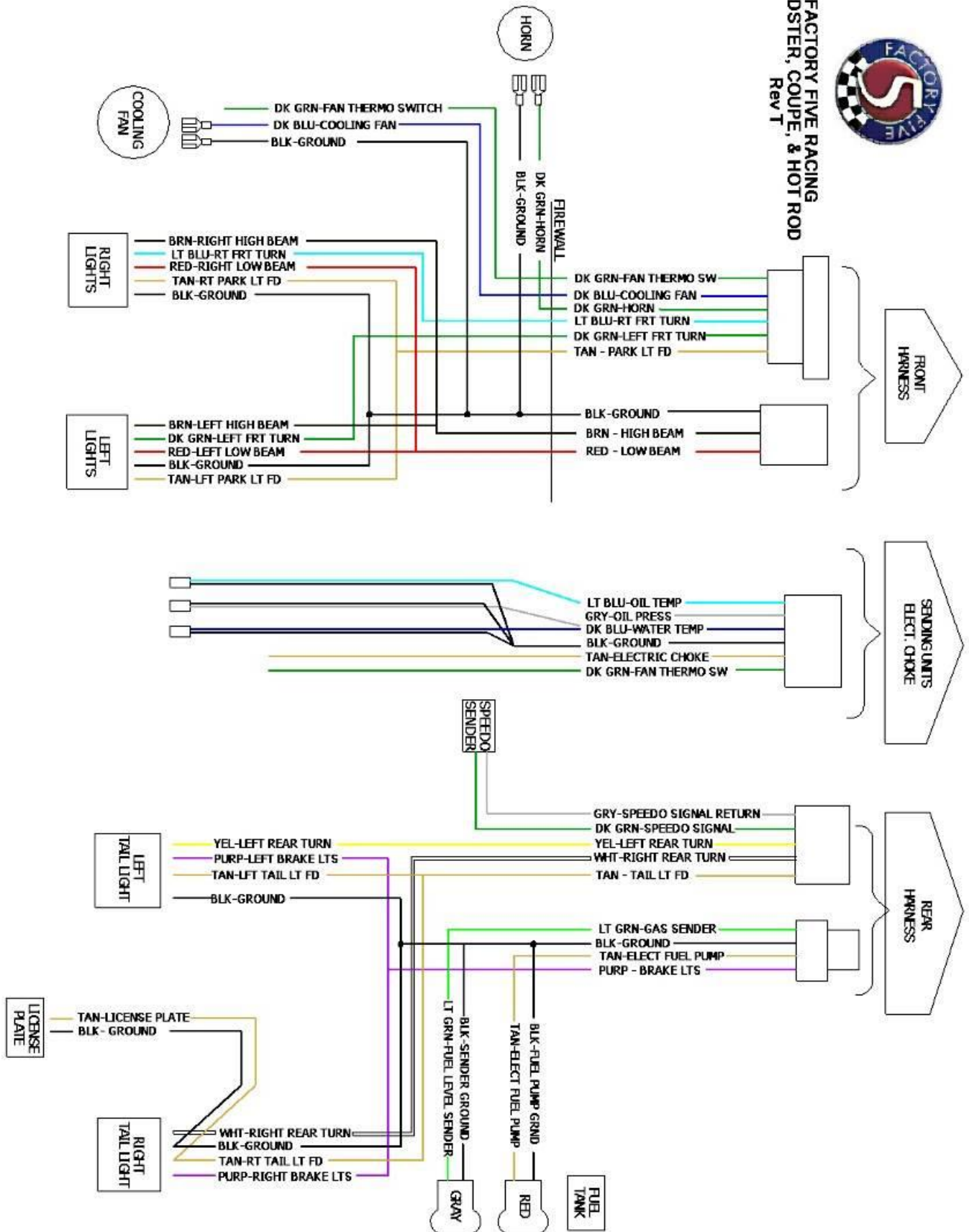

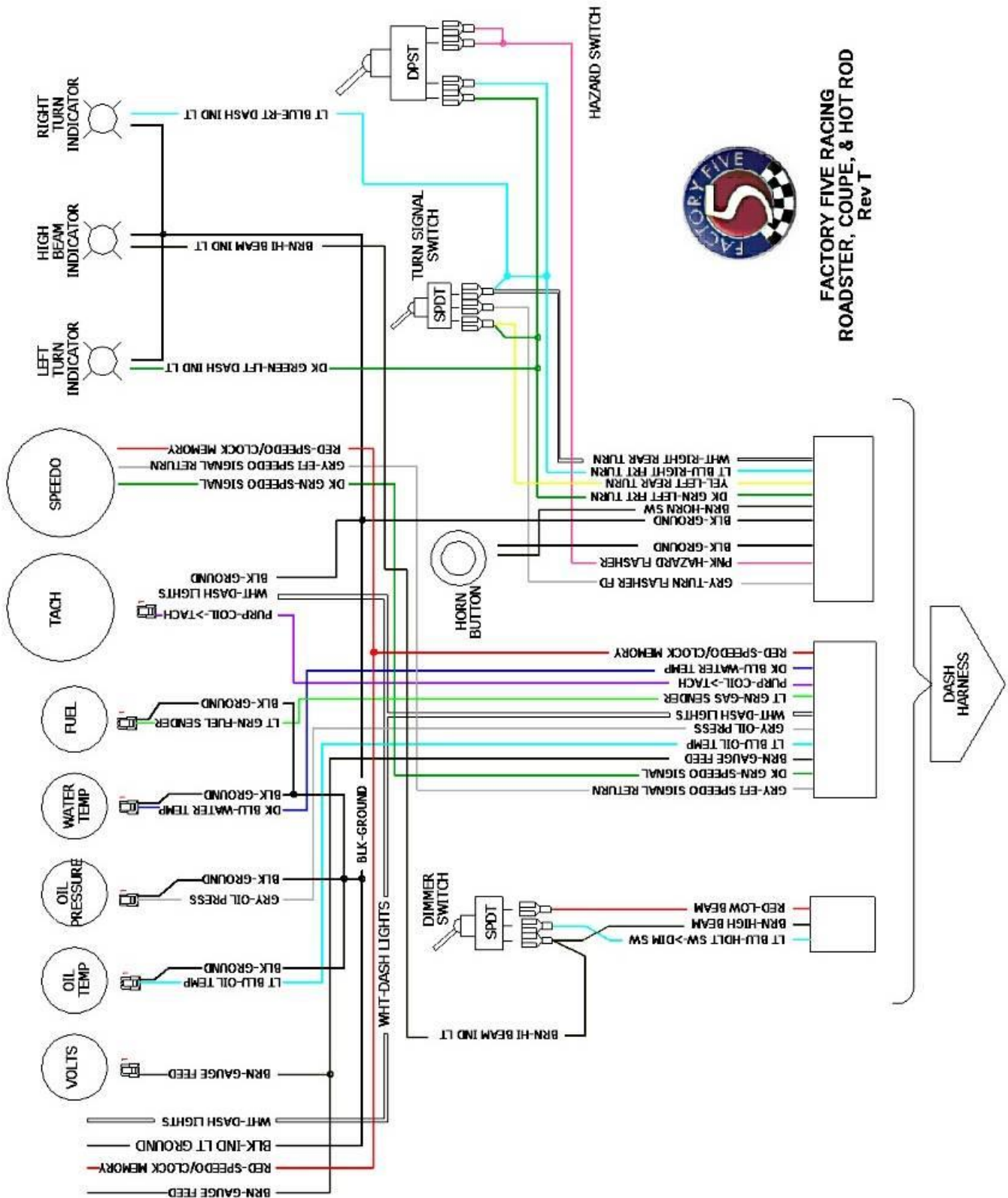



Connect the rear harness connectors to the connectors on the main harness.

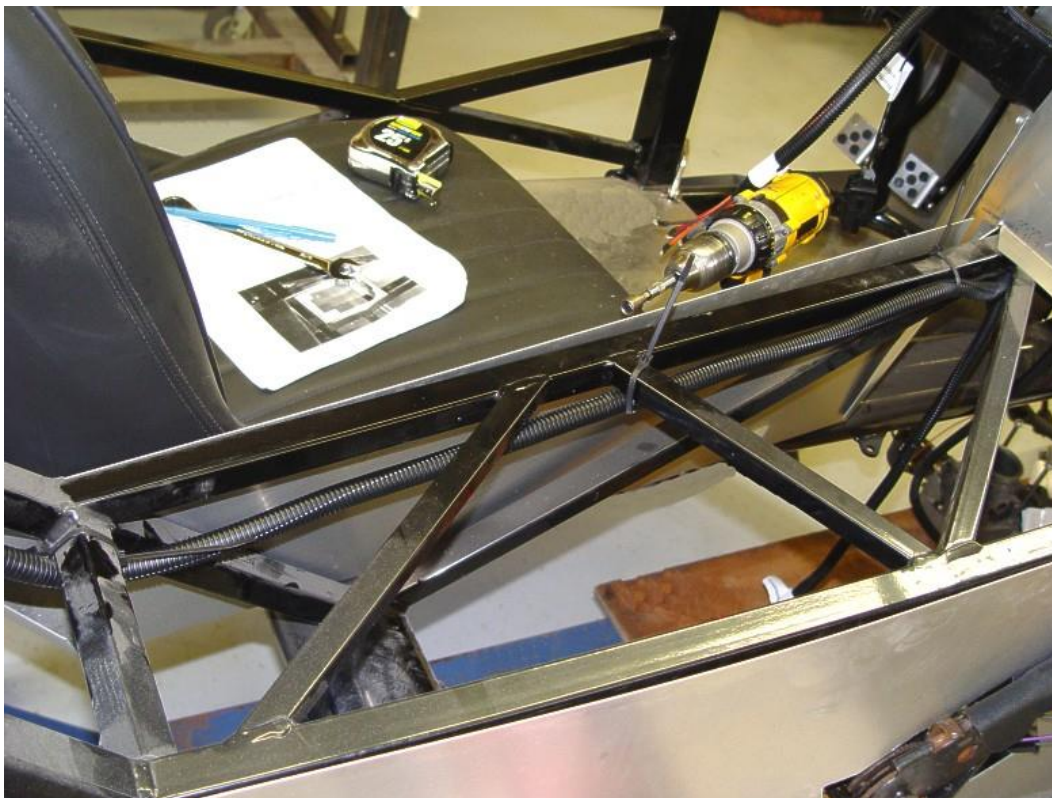

Using zip ties included with the kit to hold the harness in place, run the harness along the driver top transmission tunnel tube and up to the 2"x 3" tube at the back of the cockpit.



If your speedometer or engine computer requires a speed signal, connect the speedometer sender plug to the sender in the transmission. If it is not required the pigtail can be zip tied to the harness to prevent catching on anything or rattles.



Run rear harness down the center of the rear frame $\frac{3}{4}$ " tubes to the back of the frame. Make sure to leave enough harness at the back of the 2"x 3" tube (arrow below) so that the aluminum for the trunk can fit properly





The harness “Y” should be at the back of the frame. If it is not, you may have too much harness in the footbox or it may be too loose in the transmission tunnel.



At the back of the frame, run the harness to the correct side of the frame as marked.

FUEL CONNECTORS



Attach the gray fuel level sender plug to the sender in the fuel tank.

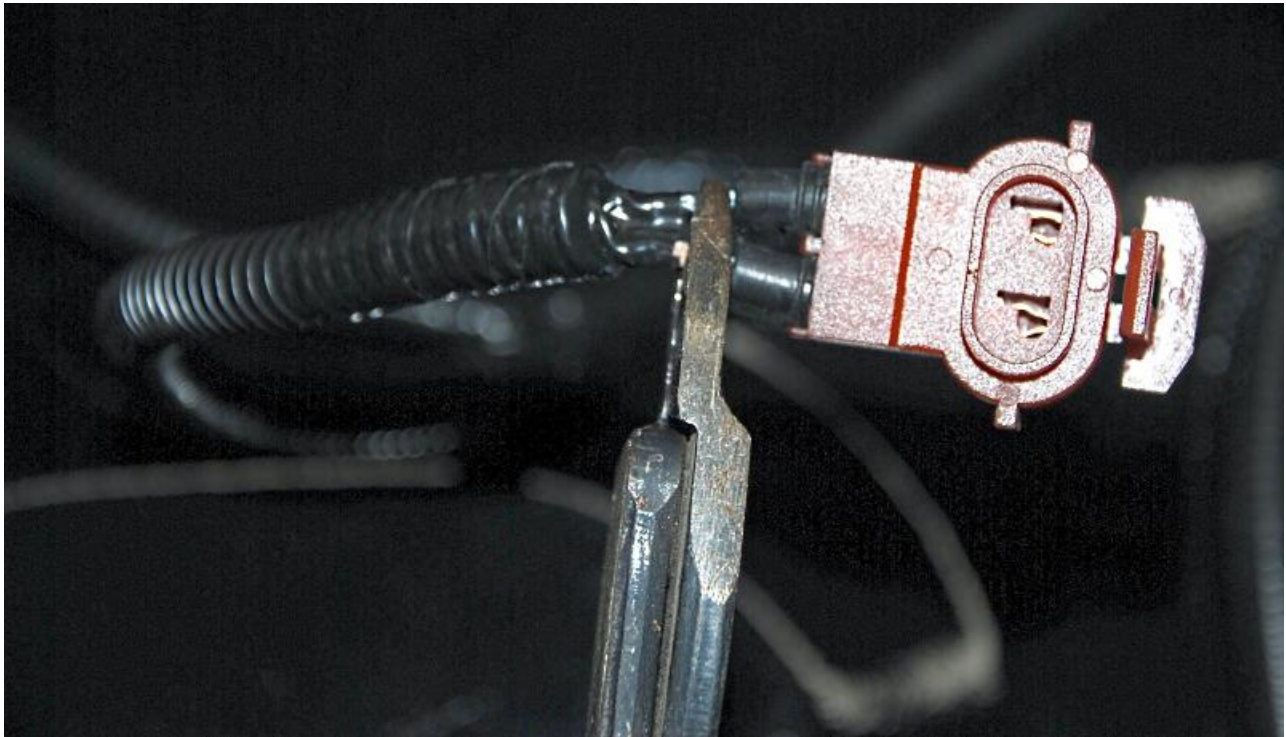

If running an in-tank pump, connect the fuel pump plug to the higher connector on the fuel tank. If running an inline pump, cut the red connector off and connect it to the fuel pump using connectors from the fuel pump.

LICENSE PLATE WIRING

Roadster



Run the license plate light wires from the passenger rear corner up the outside of the trunk to the arched trunk tube.

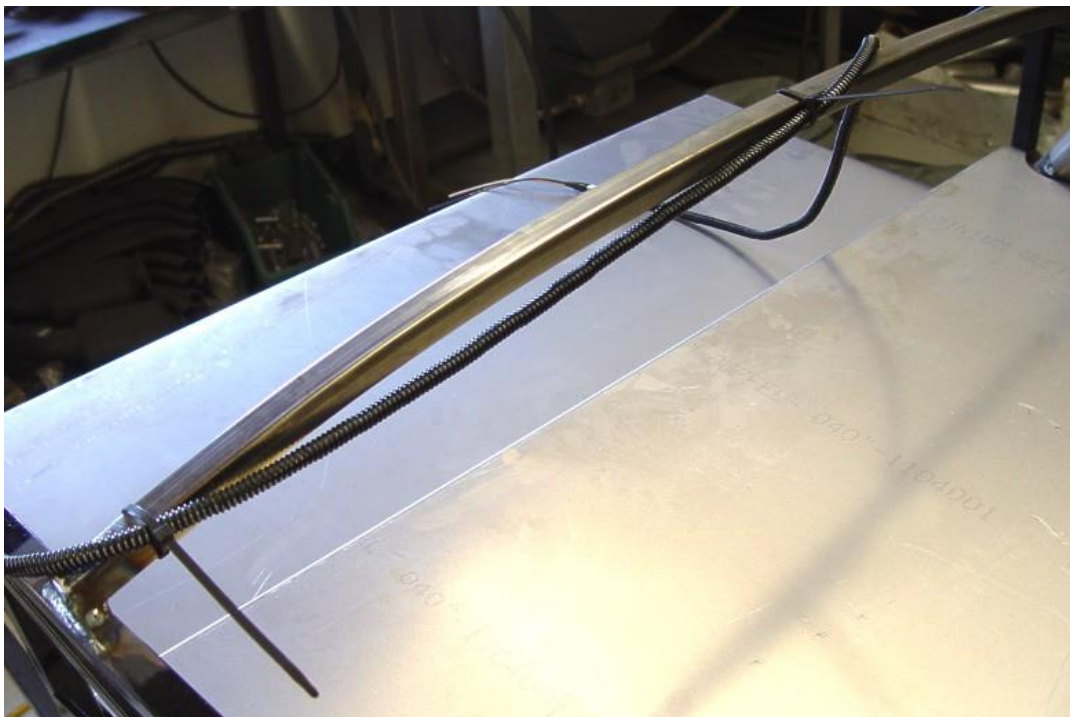

Run the wires along the back of the arched tube to the center of the trunk for now.

Coupe

Leave the license plate wires at the passenger side rear for now.

If not already done, mount the trunk side aluminum pieces.

Permanently attach the harness to the frame using the insulated clips and $\frac{3}{16}$ " rivets supplied with the kit.

Hot Rod

See assembly manual.

TAILLIGHTS

Roadster

Black – Ground

Red – running lights

Green – stop/turn signal



The tail lights can be set up so that one light does the brake, the other does the turn signal and they both do the running lights.

Twist the running lights for the lights together and solder to the brown wire

Twist the grounds for the lights together and solder to the correct wire

Coupe

White – Ground

Black – running lights

Red – stop/turn signal

Hot Rod

White – Ground

Black – running lights

Red – stop/turn signal

Gauge Sending Unit Harness



There are a couple of ways to run the sending unit harness into the engine bay depending on number of additional wires that will need to go into the engine bay possibly from an EFI harness if one is being used for the engine.



The chassis harness has wires in it for Factory Five gauges and Autometer gauges.



- ✎ The grommet hole on the sending unit harness is too large. It can be run through the same grommet as the rear harness.
- ✎ The instructions below show a carbureted engine type of install.

If not installed, install the sending units for the gauges in the engine as described in the gauge installation instructions.

Remove the grommet from the sending unit harness.



From inside the cockpit, push the sending unit harness through the rear harness grommet into the engine bay.



Connect the sending unit harness connector to the main harness connector.



The Vintage gauges oil pressure sending unit requires 3 wires. The oil temp gauge wire can be used for the third wire if an oil temp gauge is not used. If an oil temp gauge is used, run the oil pressure sending unit harness to the sender, **Do Not** cut it as shown in the following step



If using the Factory Five Vintage gauges, cut the sending unit plugs off the water temp and oil pressure sending unit wires leaving 1"-2" of wire on the plug.

Run the harness wires down the center of the engine to the gauge sending units.

Attach the plugs to the sending unit harness, black is ground and the white plug wire goes to the colored sending unit wire.

Electric Fan



The harness is designed to use a thermostat switch to control the fan.



A thermostatic switch will turn the fan on at 185° and off at around 150°.



The thermostat switch is included with complete kits and the Hot Rod kit.



If the engine being used is fuel injected and the computer has the ability to control the fan this is the best option.

ENGINE CONTROLLED FAN

Follow the instructions for the particular engine being used. The engine-controlled fan wire can either be wired directly to the fan or back to the fuse panel depending on the wire location on the chassis. If running to the back of the fuse panel, connect to the blue wire after the fuse leaving the wire connected to the fuse as well if running an A/C. If no A/C, the wire can be cut, relay and fuse removed and directly connected to the blue wire.

Ground one of the thermostat switch green wires if not cutting the wire.

If running an A/C, use the instructions included to connect the ground for the trinary switch.

THERMOSTAT SWITCH CONTROL

There are two locations in the harness available to run the electric fan using a thermostat switch; either in the engine in an engine coolant passage or in the radiator or radiator hose.

- ✎ If the engine computer is controlling the fan then the thermostat switch wires should be grounded
- ✎ The thermostatic switch works best installed in the engine. If this is not an option then it can be installed in the radiator.

Engine location

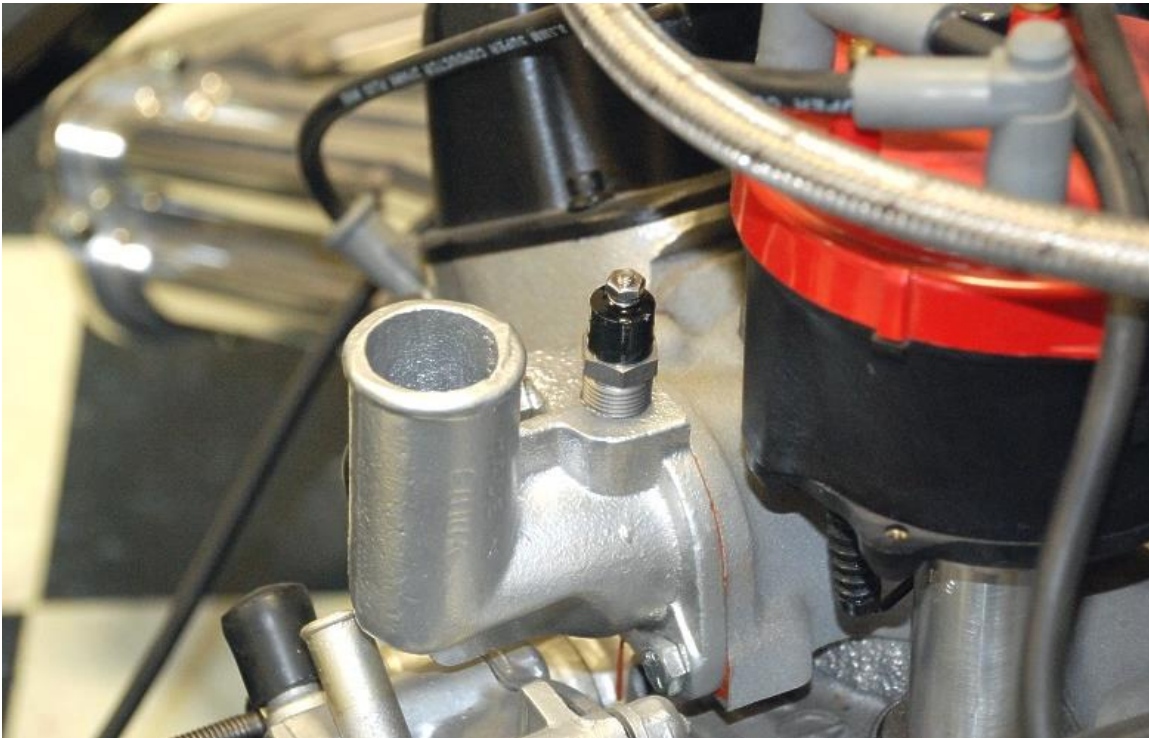

In your engine block or cylinder head locate a coolant access point to install the thermostat switch and thread it in.

Attach the “Fan Thermo switch” wire to the thermostat switch.
Follow the remaining fan wiring in the front harness.

Radiator location



Insert the electric fan thermostat switch in a threaded bung on the radiator.

If installed, connect the green thermo switch wire located with the fan wires to the thermostatic switch.

Front Harness

Find the front harness in the box.



Pull the front harness all the way through the small right hole in the front of the footbox.



Pass the entire front harness connector through the hole and insert the grommet into the hole in the plate.



Attach the two harness plugs to the correct plugs on the main harness and use one of the kit insulated clips to hold the harness up above the moving pedal parts.

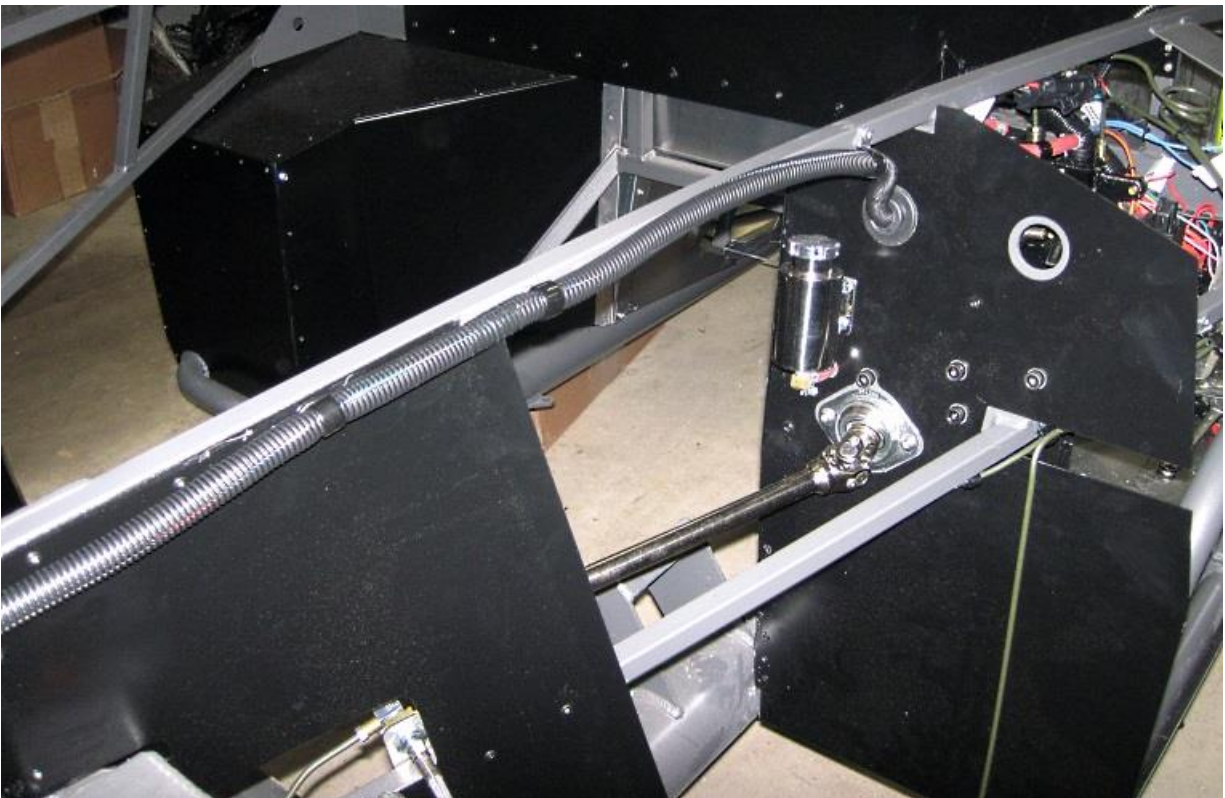

Using zip ties to hold the harness in place, run the front harness along the outside top $\frac{3}{4}$ " tube to the front of the frame. Make a notch in the top of the "F" panel for the harness to pass through.

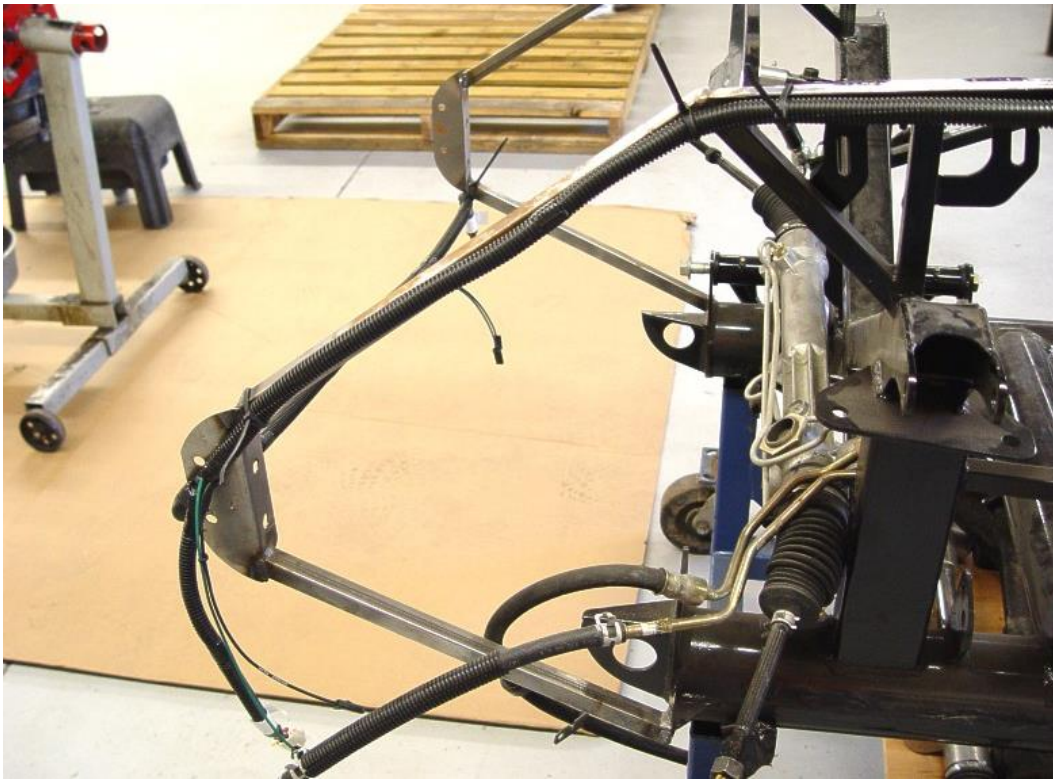

Front harness going down to the front of the frame.

Attach the harness to the channel along the bottom of the radiator.



Attach the harness to the front of the frame on the passenger side.

Permanently attach the harness to the frame using the insulated clips and 3/16" rivets in the kit.

HEADLIGHTS/TURN SIGNALS

Twist the running lights for the lights together and solder to the brown wire

Twist the grounds for the lights together and solder to the correct wire

ELECTRIC FAN

Connect the fan to the wires in the harness.

Dash Harness/Gauges

- ✎ Additional holes will need to be drilled in order to install the high/low beam switch and turn signal switch in the dash. Keep in mind when locating the switches, how hard it is to reach them and if they will interfere with your hands when they are on the steering wheel. It is easier to drill these holes before covering the dash or at least before installing the gauges.
- ✎ Factory Five has a padded vinyl dash with glovebox available as an option for use with the Vintage gauges.
- ✎ This harness is set-up to use the turn and high beam indicator lights when positioned above the steering column if not using the Factory Five Vintage gauges with built in indicators.
- ✎ The ignition switch and headlight switch have longer wires and can be located in other positions that the ones used in this layout. The headlight switch can go on the other side of the speedometer if desired.
- ✎ The dash harness has the connections for the Vintage gauges, If using the Autometer gauges cut the connectors off and use the connectors provided with the gauges. Use the instructions provided with them, the installation is much easier.

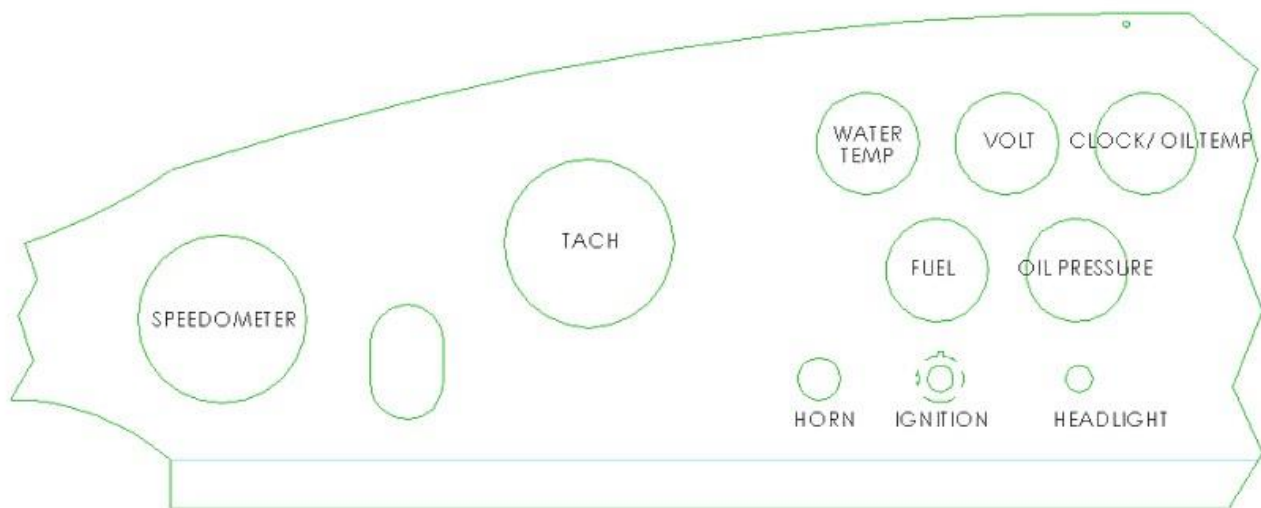

Standard Roadster laser cut gauge layout.



Possible switch/key layout.

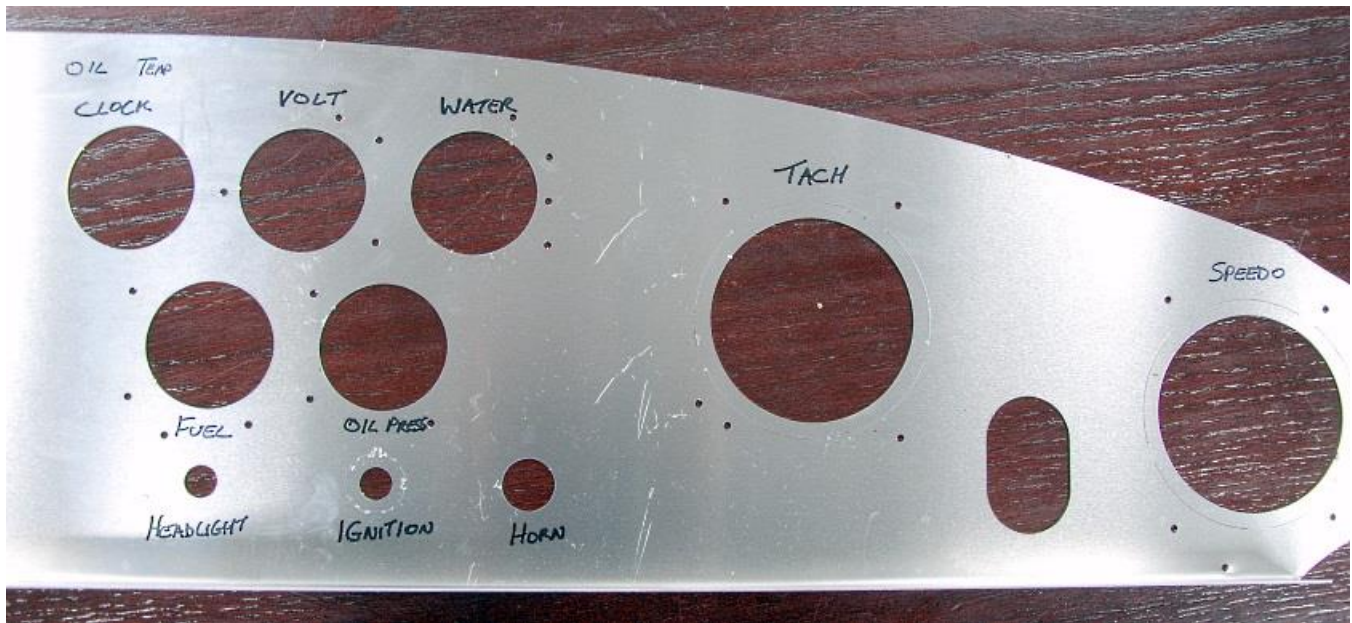

Write the names of the gauges next to their holes on the backside of the dash for easier and correct installation

AUTOMETER GAUGE INSTALL

- 🚗 Autometer gauges, gauge install components, kit cable ties
- ✂ Wire strippers, Wire crimpers



Install the gauges in the dash using the gauge instructions and the standard layout.

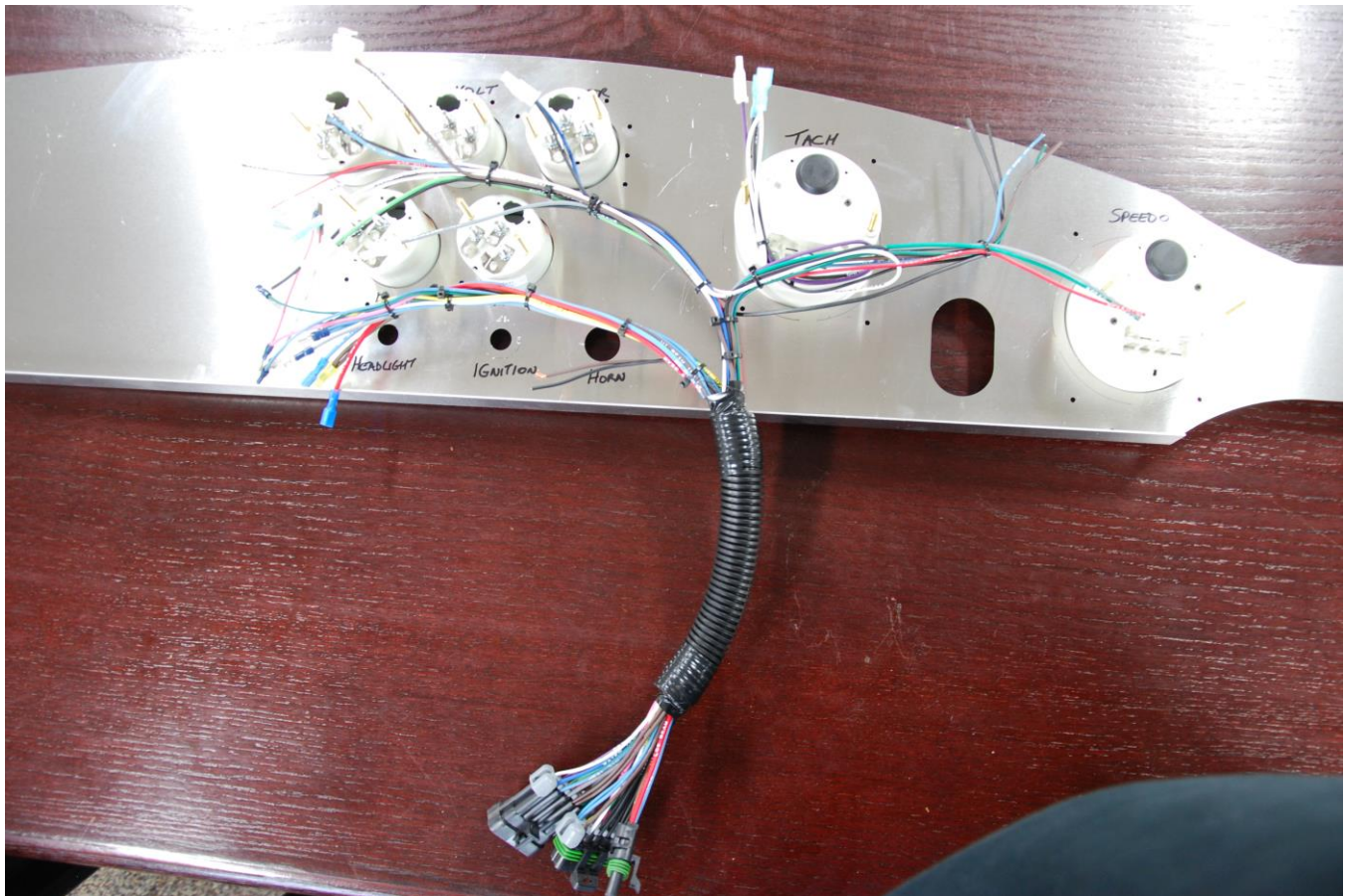

Lay the gauge harness around the gauges as shown.

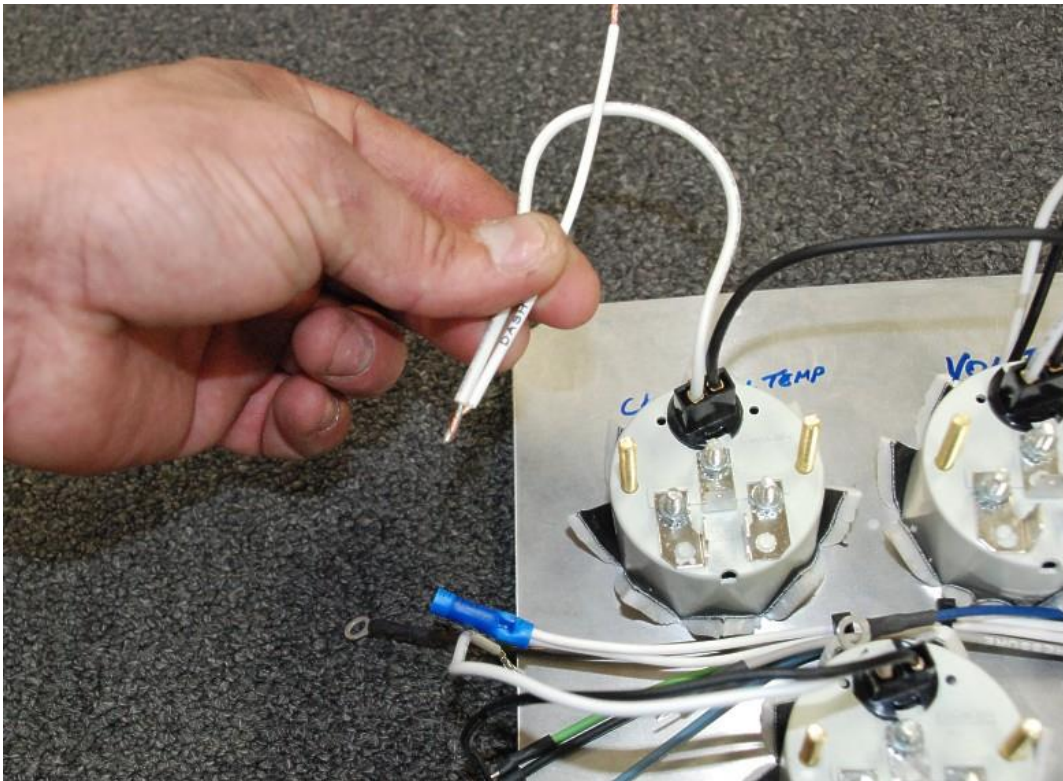

Twist the gauge light power wire from the Oil Temp gauge with one of the small white jumper wires.

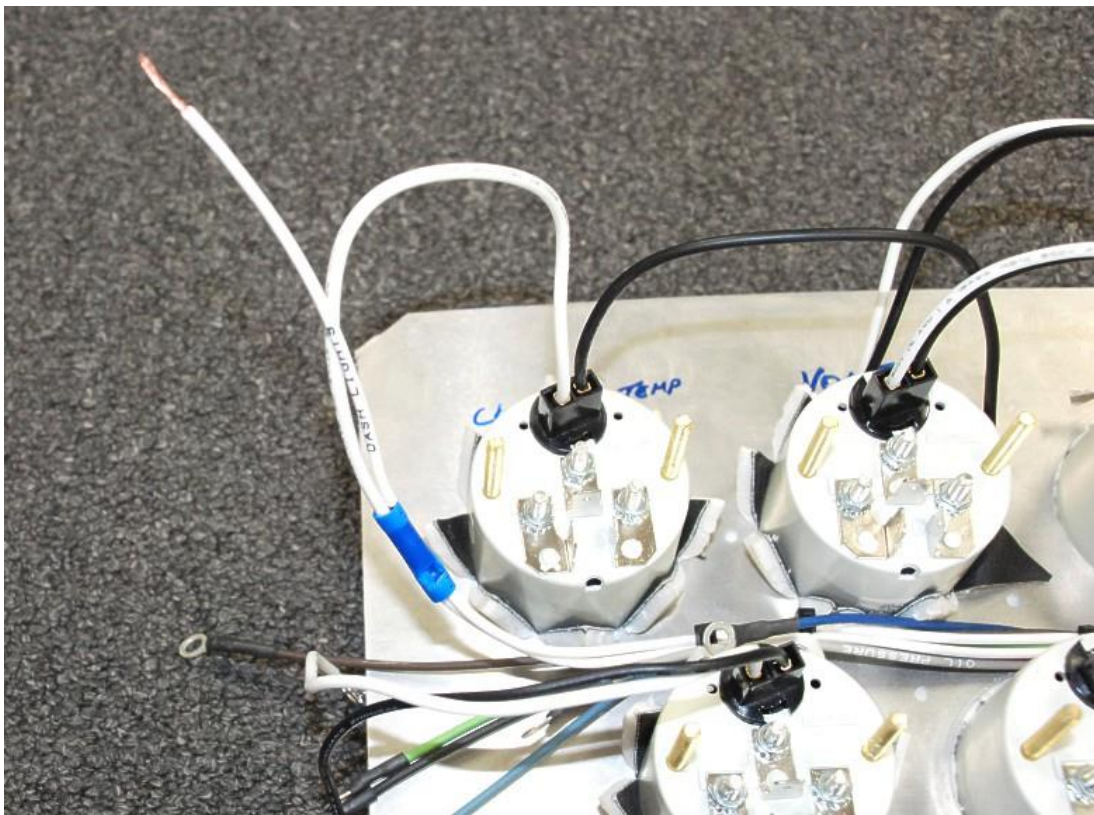

Connect the twisted wire to the white gauge light power wire.



Connect the remaining small gauges in series using wire included with the gauges. Solder the wire connections or use butt connectors. If necessary, use the butt connectors from the misc. electrical components assembly in the Factory Five main kit pack. If using Butt connectors, twist the small jumper wire from the oil temp/clock with the light wire from the volt gauge and insert into one side of the butt connector and twist the gauge light wire from the water temp gauge and another jumper together and insert into the other side of the butt connector then repeat for the other small gauges.

Cut the ground wire from each of the sending unit connectors.

For each gauge, twist the sending unit ground and the light ground wires together and attach with ¼" female connectors and put each of them on the "GND" (ground) stud of each gauge.

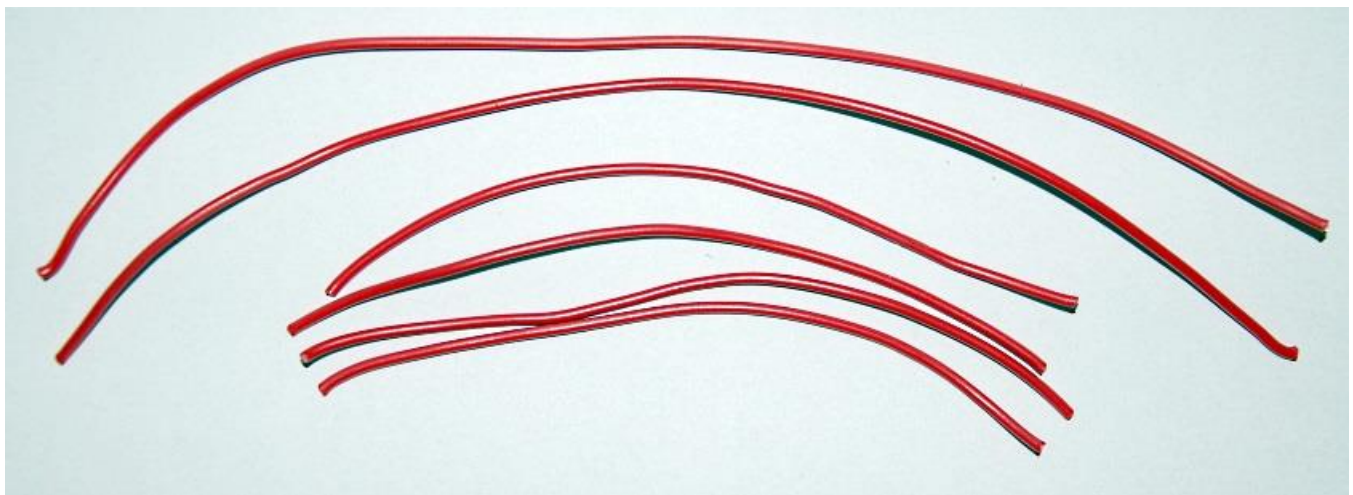

Cut the red wire that comes with the gauges into (4) 7" pieces and (2) 12" pieces.

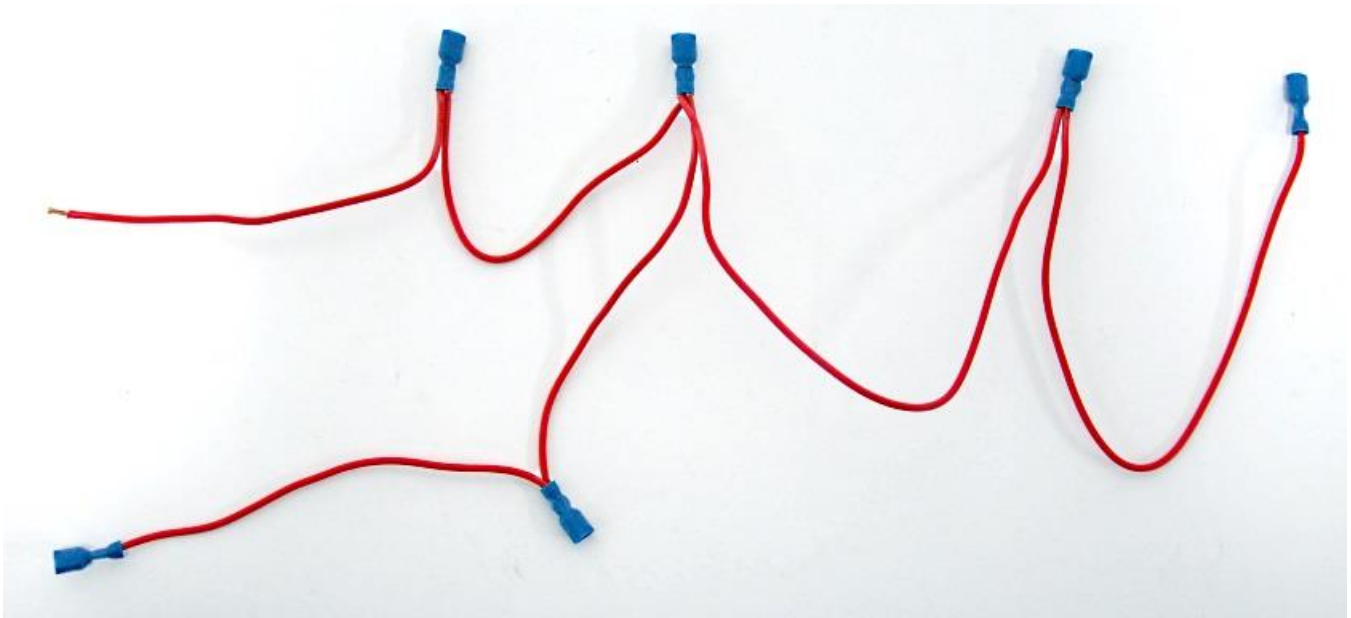

Connect the wires together as shown using ¼" female connectors.

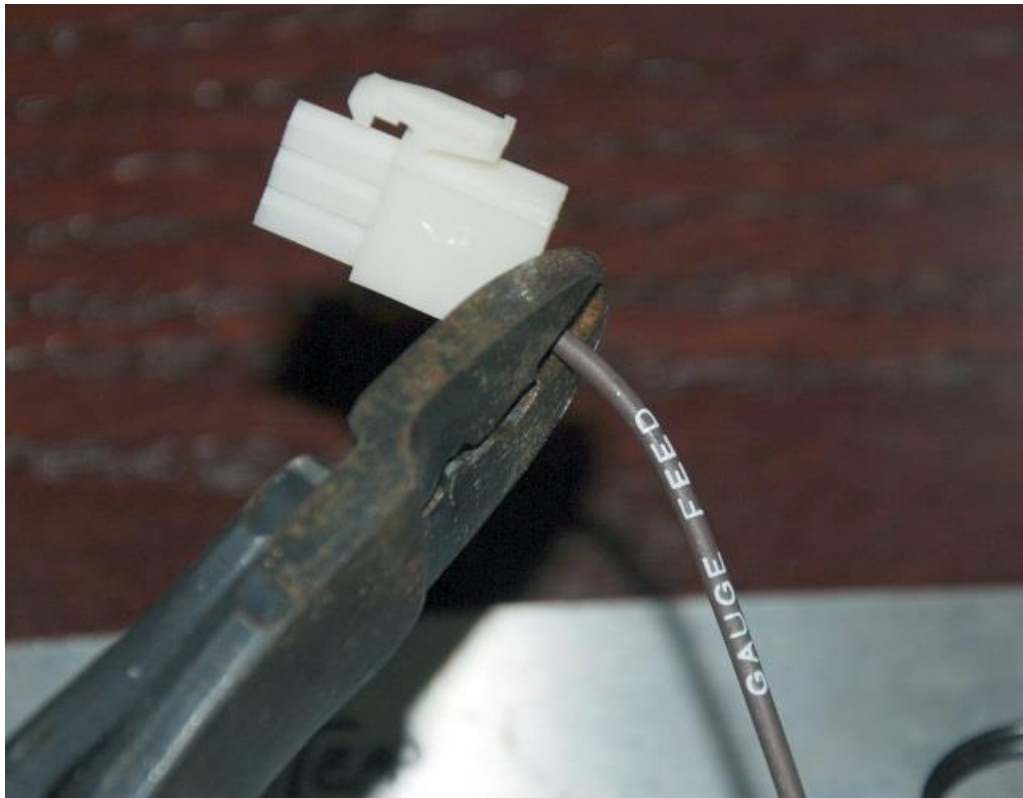

Cut the connector off the brown gauge feed connector near the volt gauge.

Twist this wire together with the end of the red jumper wire and connect with a ¼" female connector. Connect the red wires to the "I" (ignition) terminals starting with the Oil Temp. Attach each of the gauge sending unit wires to the correct "S" (signal) terminal on each of the gauges using a ¼" female terminal connector.



Connect the green speedo wire to the Speedometer using a ¼" female connector.

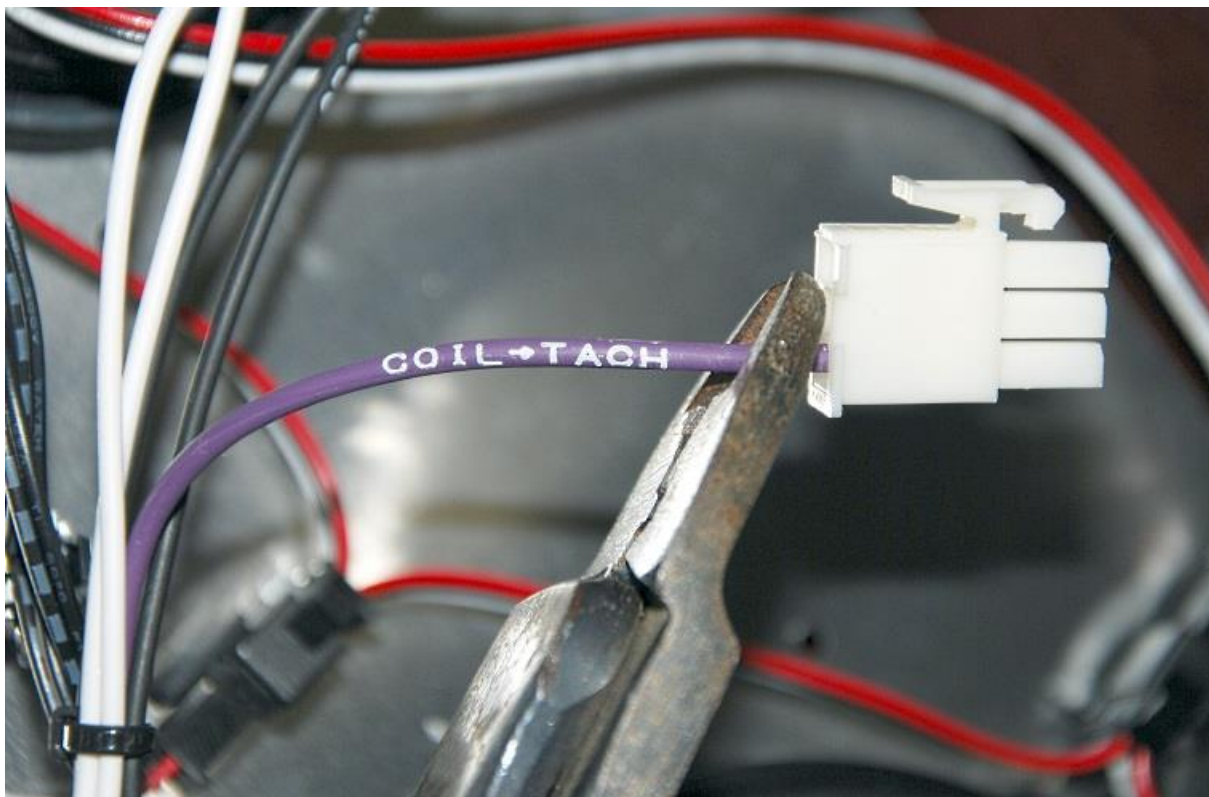

Cut the purple Tach wire from the connector.

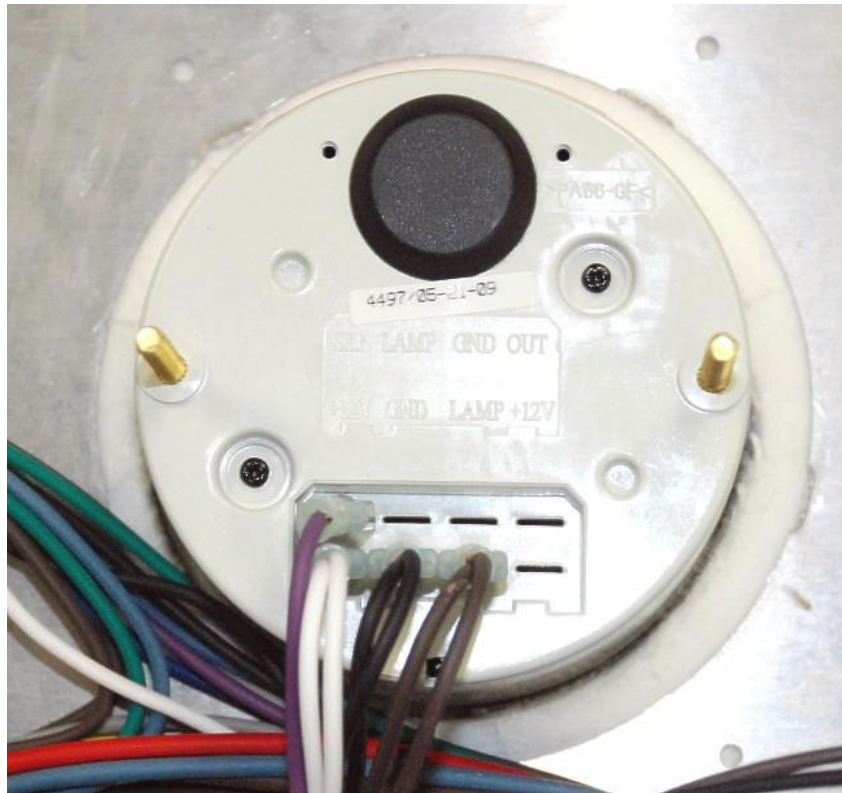

Connect the harness wires to the Tach using a 1/4" female connector.



Insert the Horn button into the dash and attach the wires to each terminal.

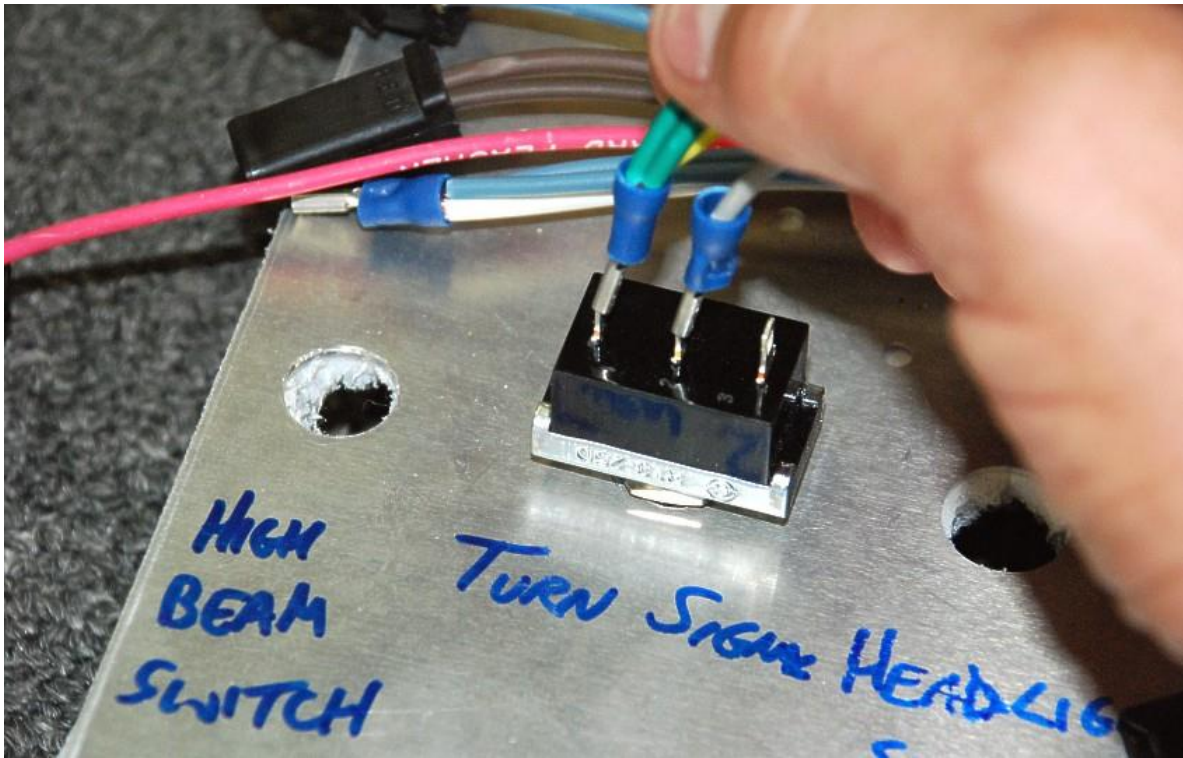

Insert the Turn signal switch into a hole in the dash and connect the wires to the terminals. Gray feed wire in the middle and the signal wires on the sides. Left turn wires on the left post and right on the right post.

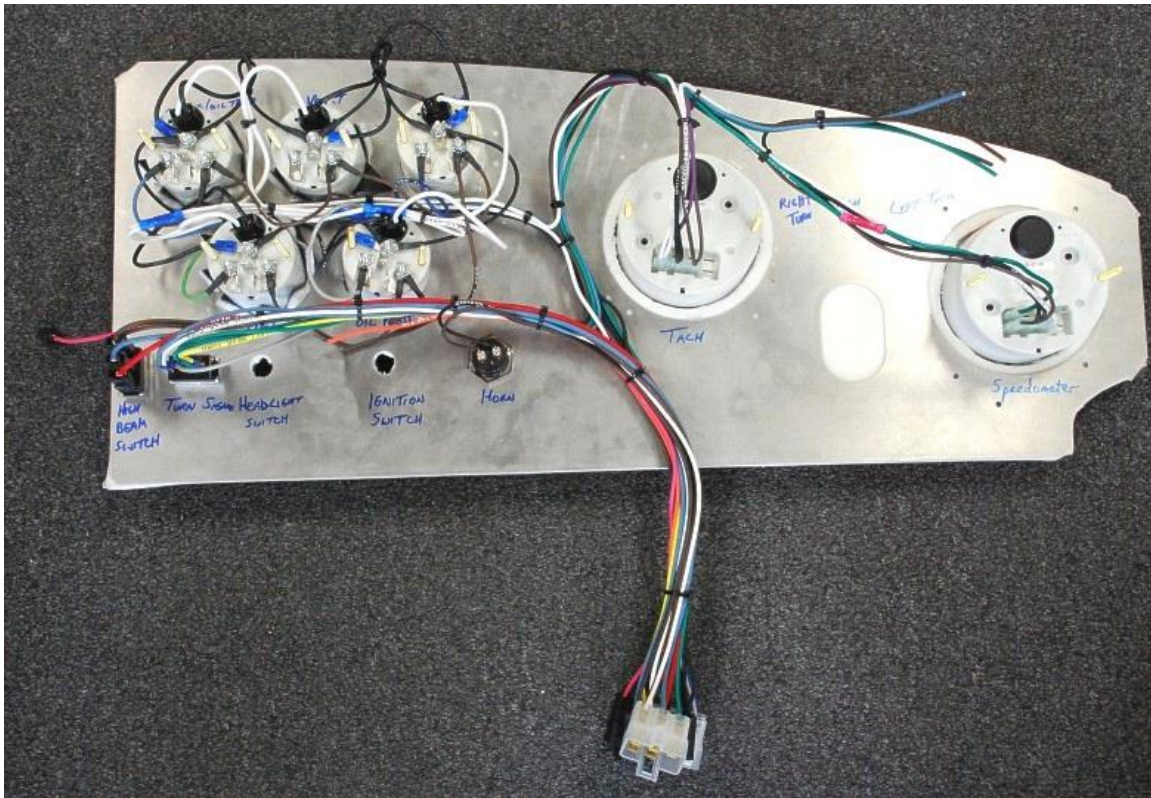

Insert the high/low beam dimmer switch into the correct drilled hole in the dash and connect the wires to the terminals. Light blue wire in the middle with the red low beam wire on the top and the brown High Beam wire on the bottom.

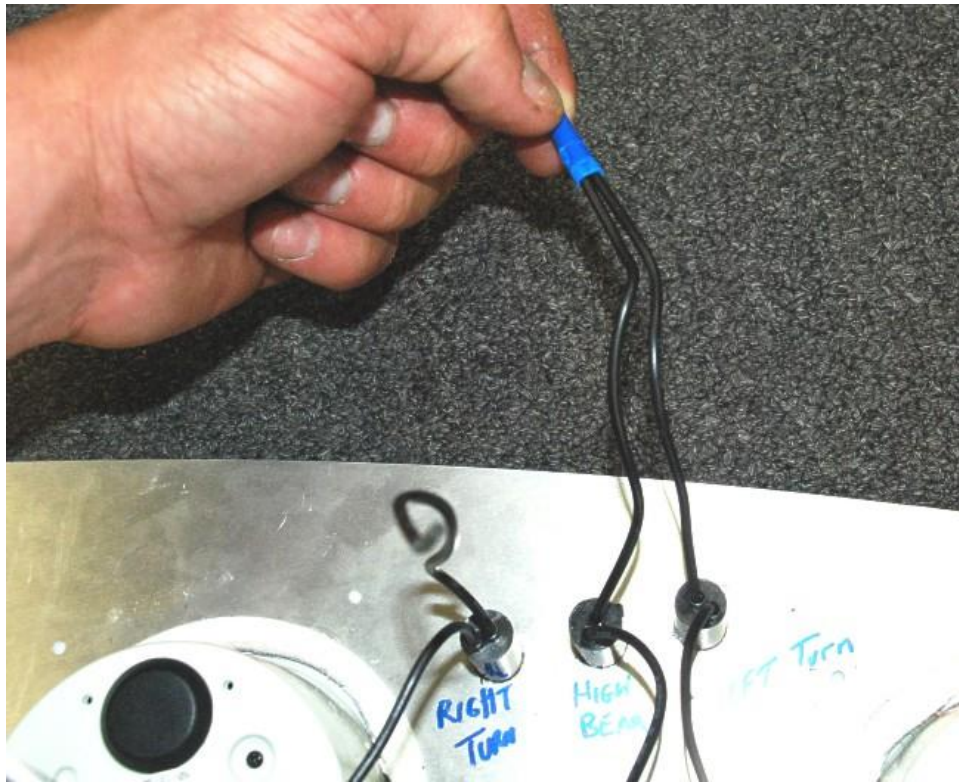

Insert the high beam and two indicator lights into the dash and twist two of the ground wires together for the lights and insert them into one side of a Butt connector.

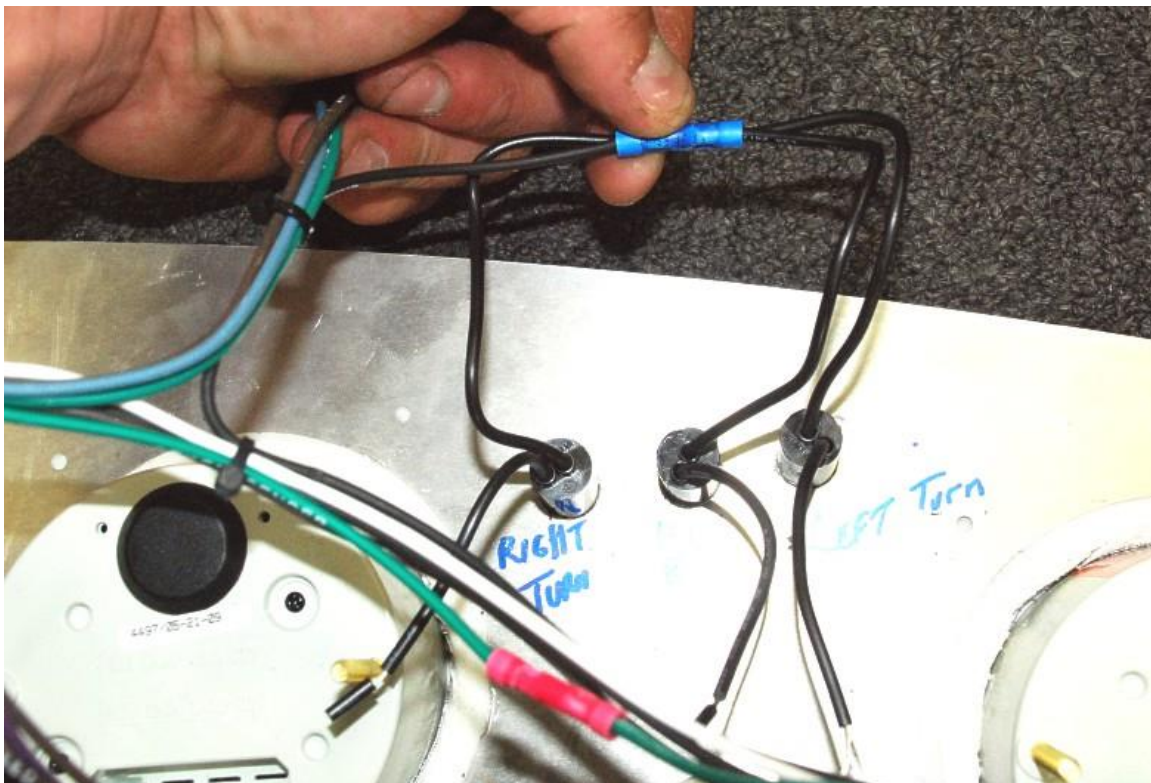





Twist the other light ground wire together with the harness indicator light ground wire and crimp it in the other side of the same butt connector.

Connect the correct signal wires to the correct indicator light.

Zip tie all of the wires together so that they do not rattle or hang down from the dash.
Position the dash on the frame using masking tape to temporarily hold the dash in place.
Position the ignition switch and headlight switch on the dash.
Remove any fuses from the fuse panel for components/circuits that are not used. This will eliminate any electrical shorts in wires that are not connected (i.e. Wiper, heater, radio, etc...)

GPS VINTAGE GAUGE INSTALL

-  Vintage gauges, kit cable ties, kit butt connectors
-  Wire strippers, Wire crimpers
-  Refer to the instructions provided with the gauges for any gauge information or calibrating instructions.
-  The knob on the gauge dial light cable adjusts the light coming through the gauge face. We recommend turning the knob clockwise all the way and zip tie the knob with other wires on the back of the dash. Use the headlight switch to dim the gauge lights.
-  The pictures show white connectors, the connectors are now black.

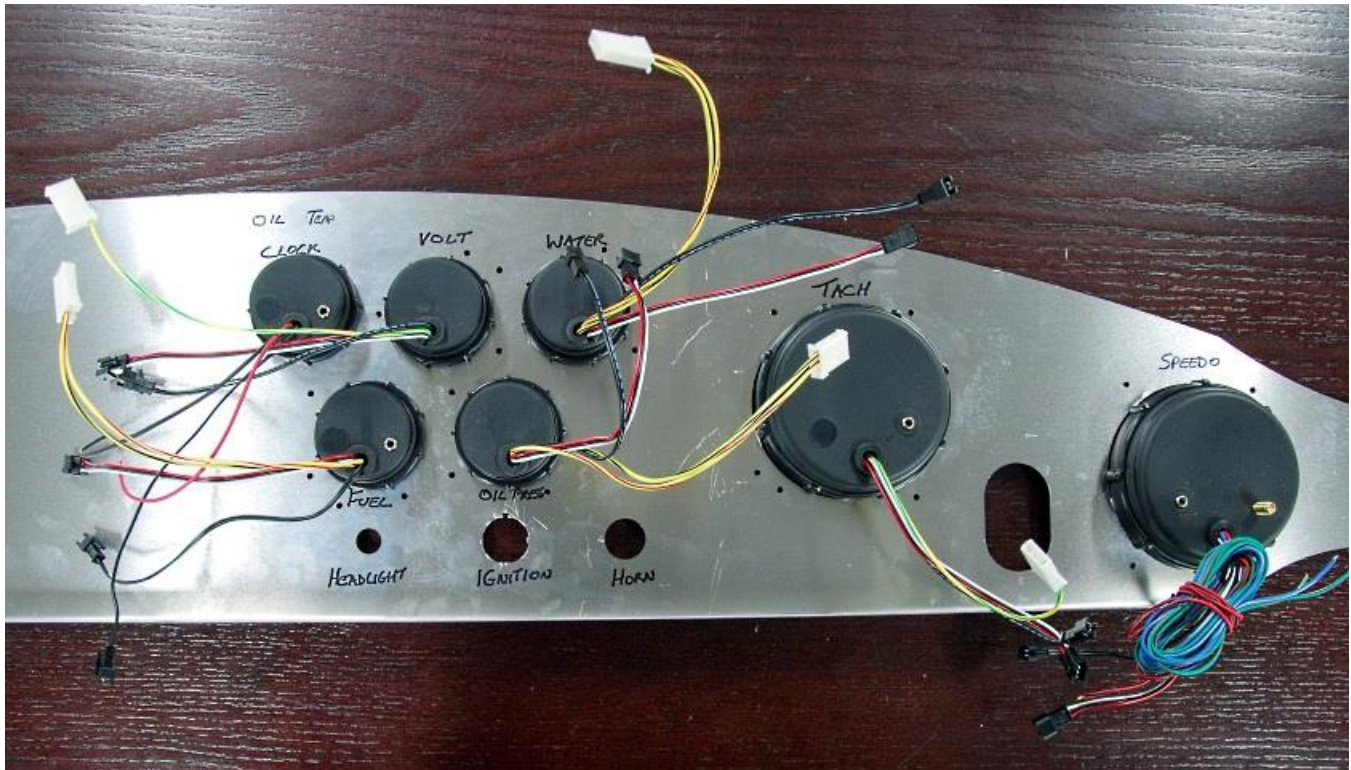

Insert the gauges into the dash with the screw-on retaining rings.

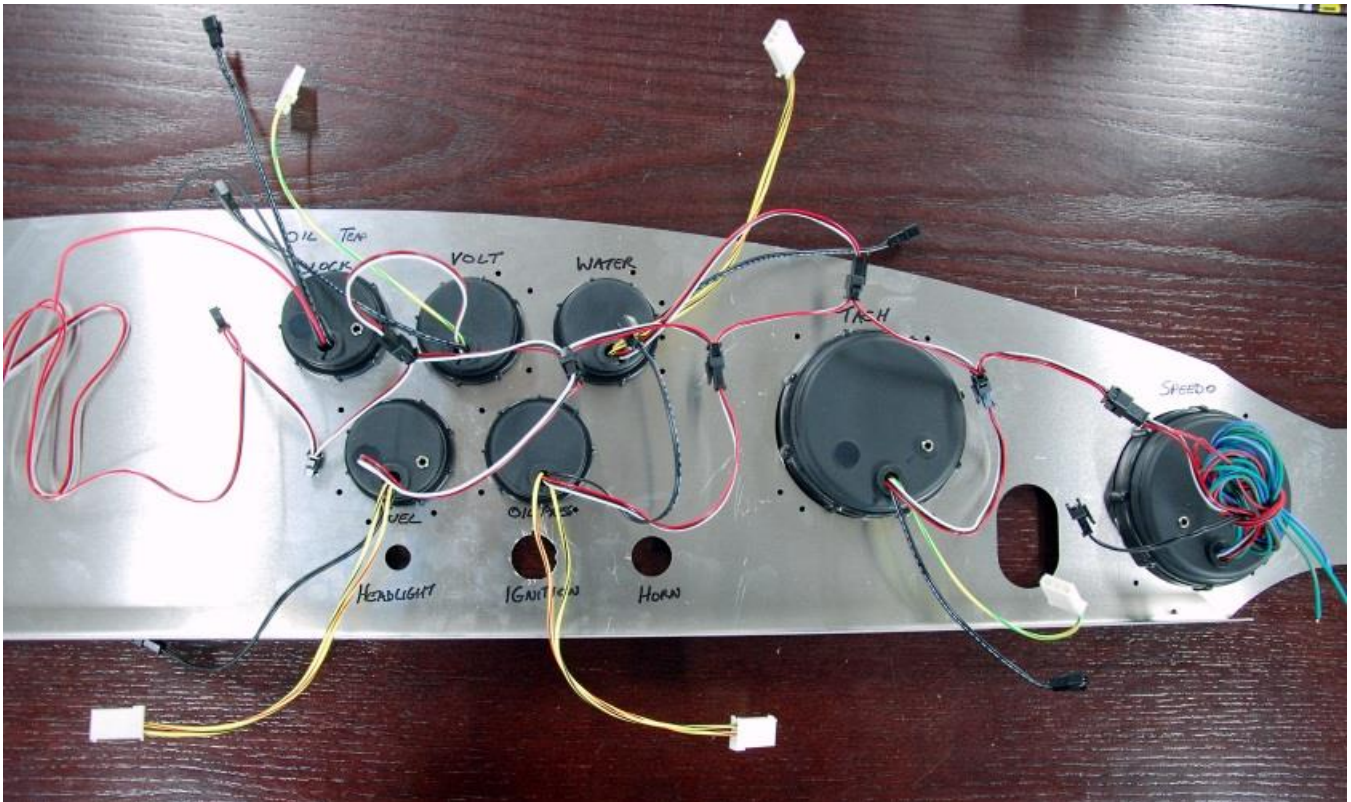

Connect the multi-color power distribution cable to all of the gauges starting with the end connector on the Speedo.

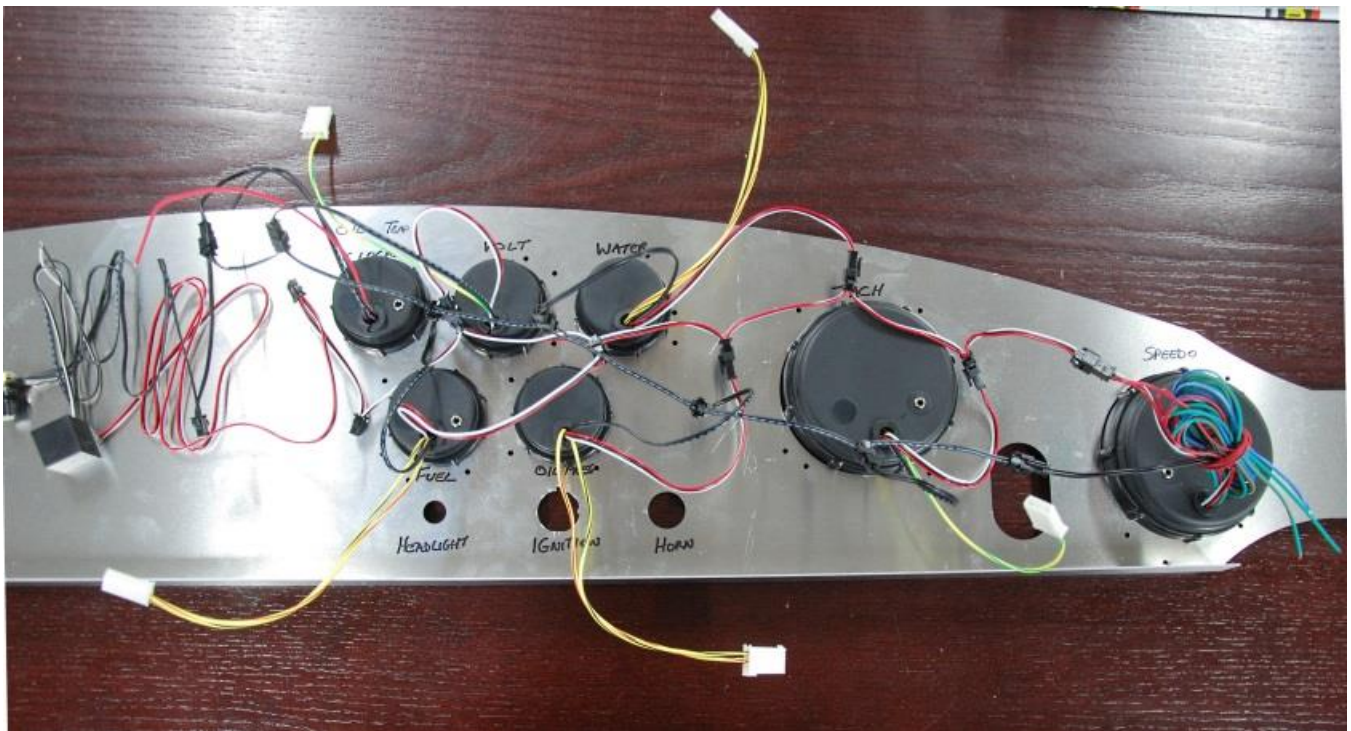

Connect the black gauge dial light cable to all of the gauges starting with the end connector on the speedo.

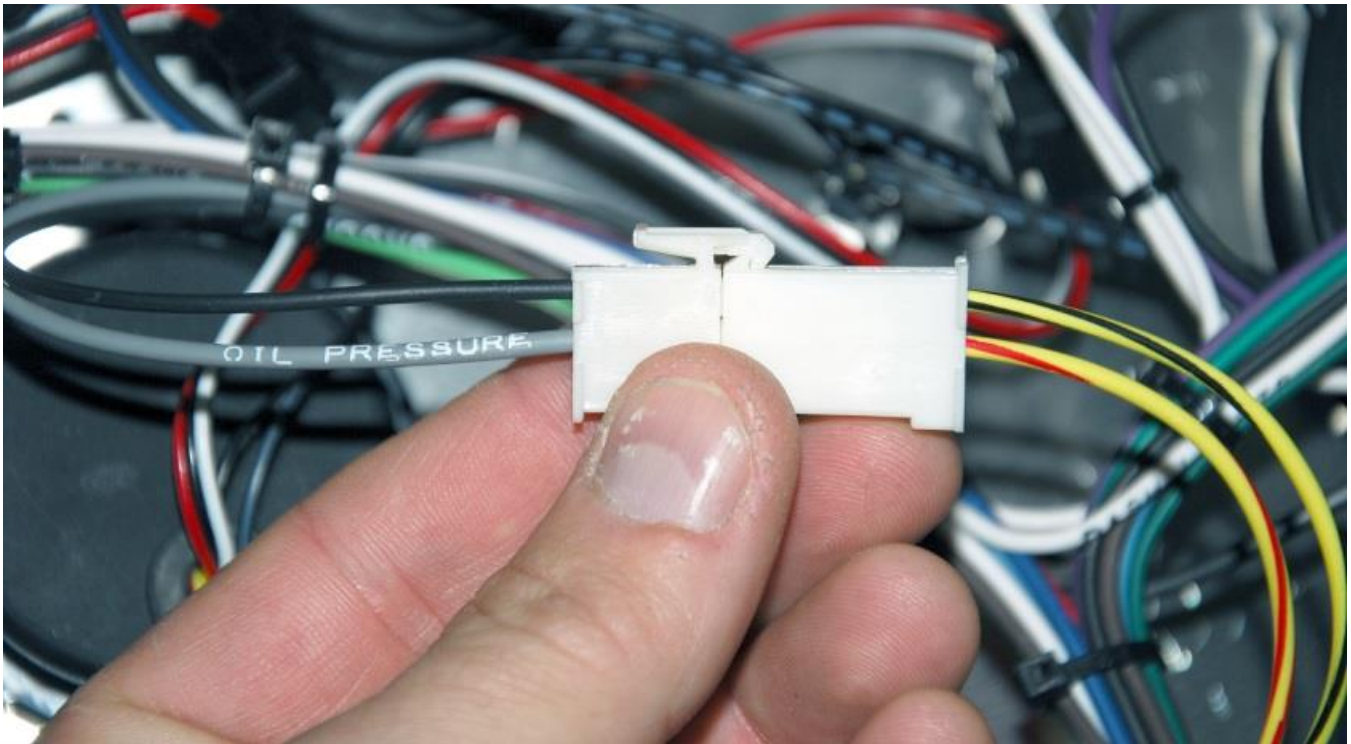

Connect each of the gauges to the correct sending unit wires.

Gauge power

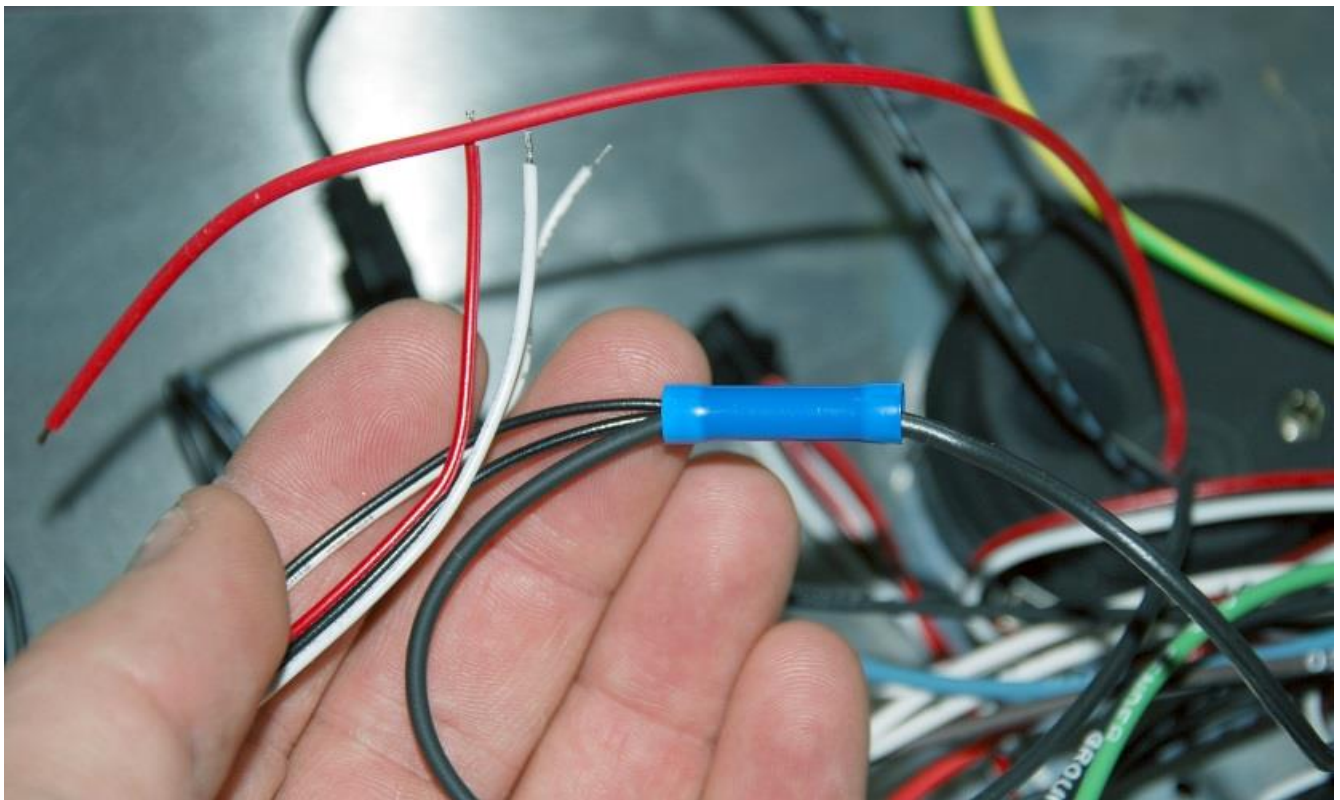

Twist the ground wires from the power distribution cable, gauge dial light cable and the clock together and butt connect or solder this to the black ground wire.

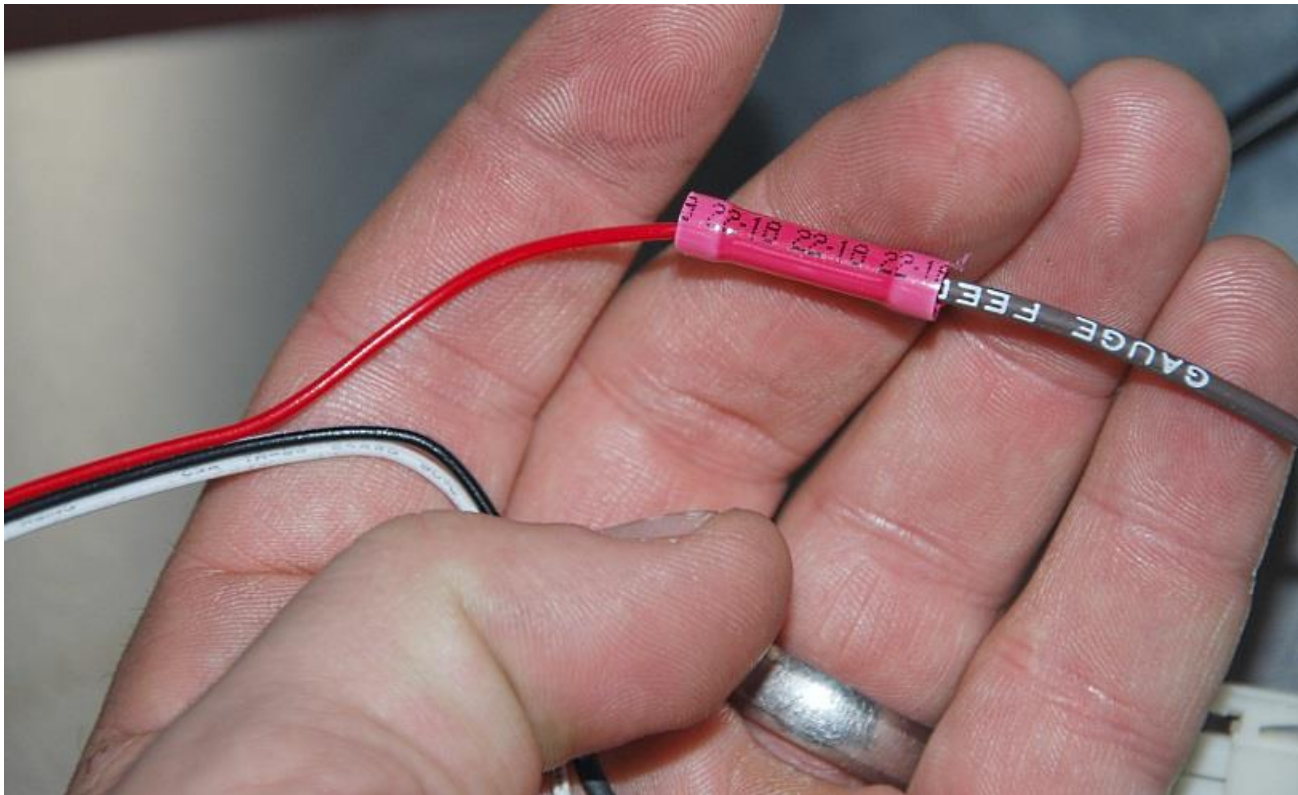

Connect the red power distribution wire to the brown gauge feed wire.



Cut the female connector off the end of the white dash lights wire.

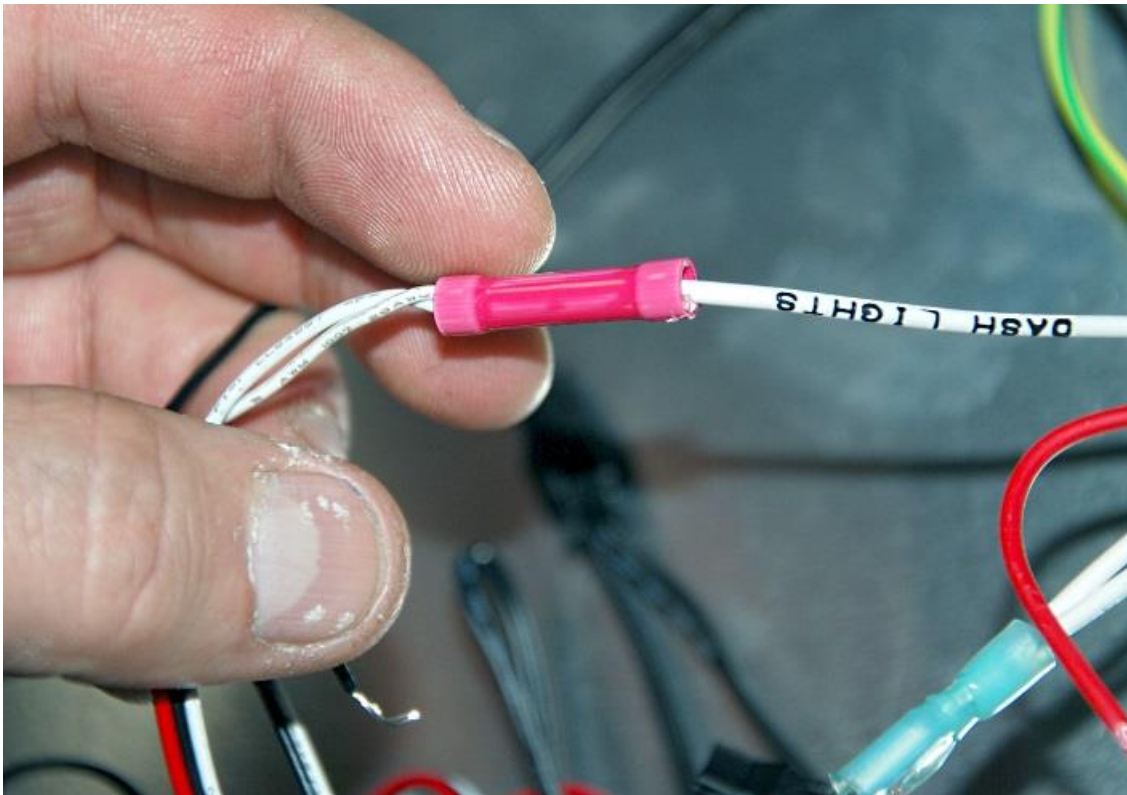

Twist the white power distribution wire and white gauge dial light wire together and connect to the white dash light wire.



The knob on the gauge dial light cable adjusts the light coming through the gauge face. We recommend turning the knob clockwise all the way and zip tie the knob with other wires on the back of the dash. Use the headlight switch to dim the gauge lights.

Clock

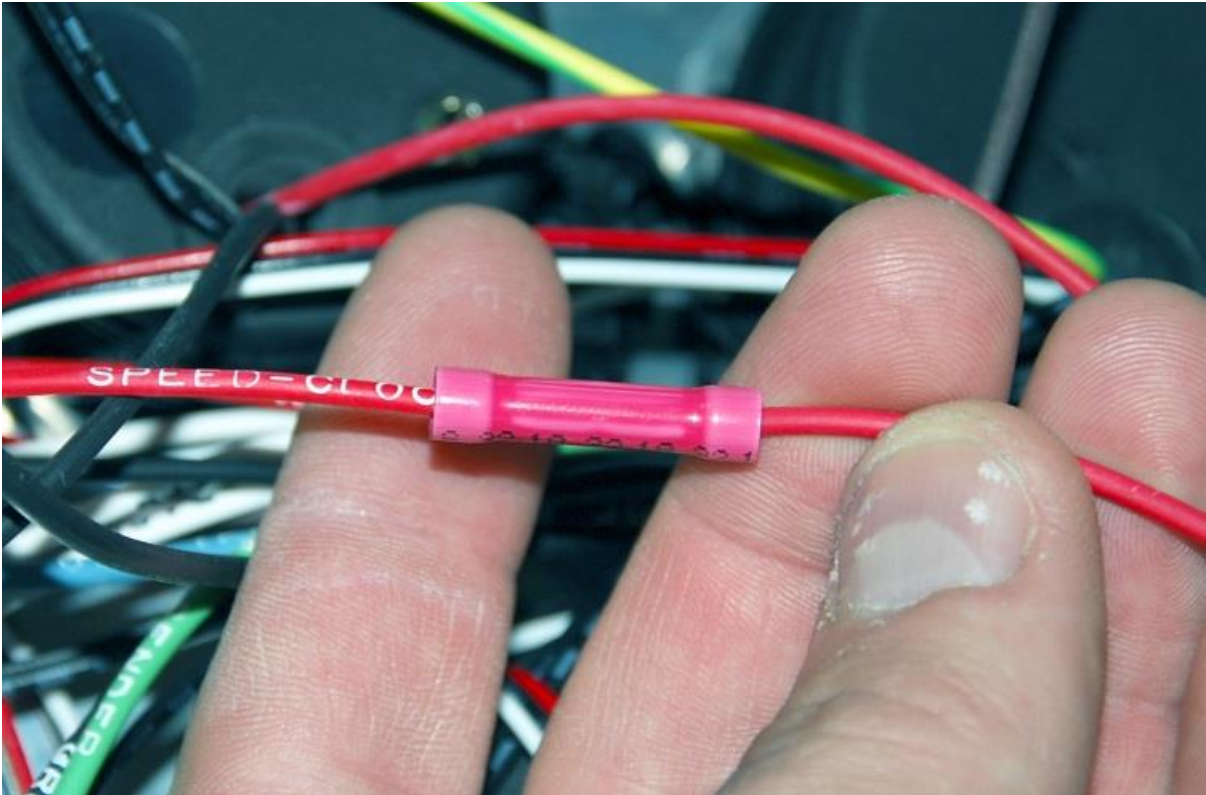

Connect the harness clock power wire to the red clock wire.

Speedometer/Indicator lights



At the Speedo, connect the harness speedo memory wire to the red/black speedo wire.



Connect the blue right turn indicator wire to the gauge green/red wire.

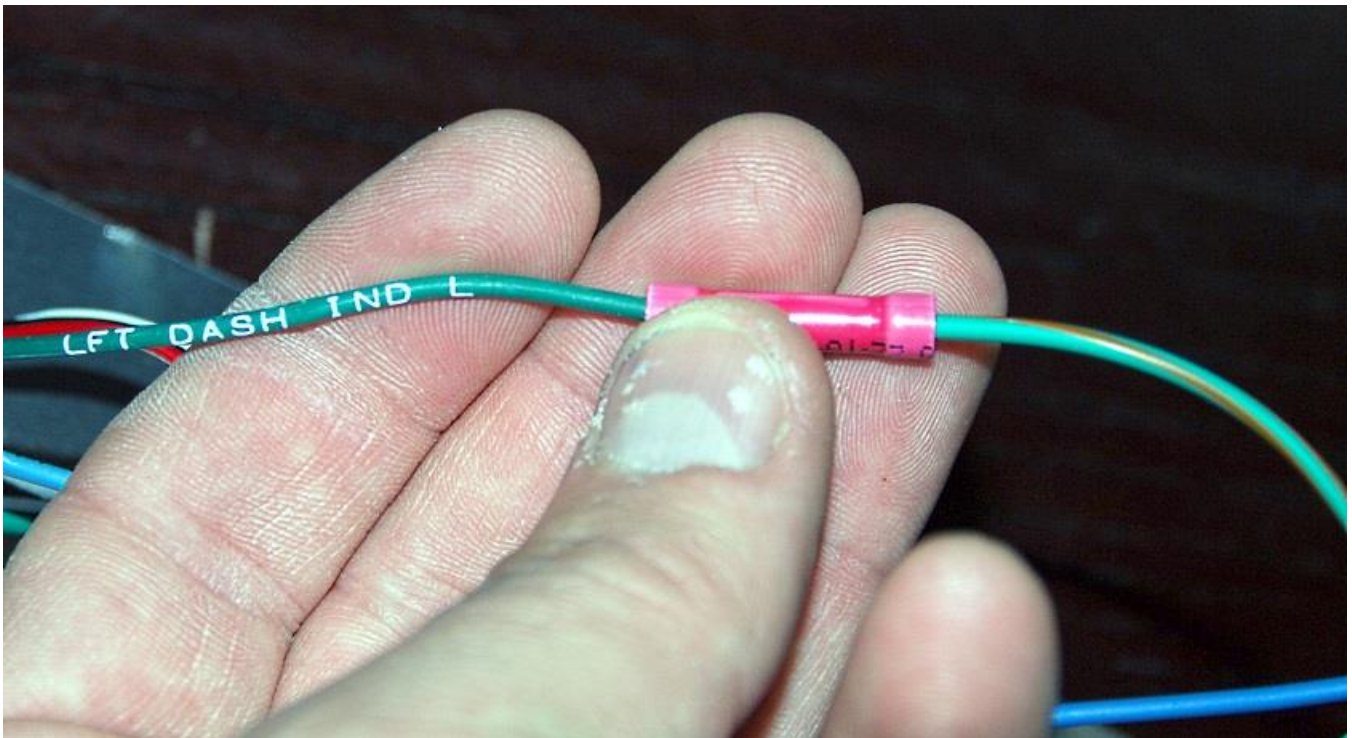

Connect the green left turn indicator wire to the gauge green/yellow wire.



Connect the brown high beam indicator light wire to the gauge blue/white wire.

Zip tie all of the wires together so that they do not rattle or hang down from the dash.

Position the dash on the frame using masking tape to temporarily hold the dash in place.

Position the ignition switch and headlight switch on the dash.

Remove any fuses from the fuse panel for components/circuits that are not used. This will eliminate any electrical shorts in wires that are not connected (i.e. Wiper, heater, radio, etc...)

Troubleshooting

Some of the areas that can cause problems are:

Inertia Switch – This switch can cause a “no start” problem. Make sure that the button is pushed down.

Wire connections – Tape connections are not recommended. The best connection is a soldered connection that has heat shrink tubing over it. If this is not possible, a well crimped connector is recommended.

Grounds – Make sure that the ground wires are connected to clean bare metal surfaces. Battery grounds must be attached to the battery.