



Factory Five Racing, Inc.

Part Number: 15471	Revision: 1F	Effective Date: 12/16/21	By: J. INGERSLEV
Document Type (indicate):			
<input type="radio"/> Bill of Material	<input type="radio"/> Drawing (may be attached)	<input type="radio"/> Specification	
<input checked="" type="radio"/> <b>Assembly Instructions</b>	<input type="radio"/> Operating Procedure	<input type="radio"/> Other	

# Roadster Gen 3 (2018) Coyote Engine

## Installation Instructions



- Parts needed ..... 3
  - Ford Performance Parts ..... 3
  - Ford Motor Co. Parts ..... 3
  - Summit Racing ..... 3
    - Fuel System ..... 3
    - Air Intake System ..... 3
  - Other vendors ..... 3
    - Autozone ..... 4
- Supplies ..... 4
- Information ..... 4
- Accelerator Pedal ..... 5
- Fuel pressure regulator ..... 11
- Drivetrain ..... 14
  - Engine prep ..... 14
  - Flywheel ..... 14
  - Exhaust ..... 15
  - Oil System ..... 15
    - Oil cooler ..... 16

Oil Pan .....	19
New flywheel/clutch .....	30
Torque Specs.....	40
Engine mounts.....	40
Starter.....	42
Oil Pressure sender.....	43
Water Temp Sender .....	44
Oil pressure sender.....	48
Transmission Prep.....	51
Engine/Transmission Installation.....	53
Alternator .....	54
Shifter handle .....	56
Fuel System.....	58
Fuel lines.....	58
Fuel pressure regulator vacuum .....	59
Cooling system.....	60
Lower hose.....	61
Upper hose .....	62
Intake air bleed.....	65
Heater core bypass hose .....	66
Air Intake .....	68
Mass Air Meter .....	68
Intake tube.....	70
Vacuum ports and PCV vent.....	71
Valve cover hoses .....	73
Clutch position switch.....	74
Using a Clutch cable .....	74
Using Hydraulic clutch .....	79
Wiring .....	80
Computer mounting .....	80
Roadster .....	80
Coupe .....	82
Harness Prep .....	82
Intercooler wire .....	82
CAN Bus Wires .....	83
Harness install.....	84
Engine bay .....	86
Fuse panel .....	87
Computer.....	91
Mass Air Meter .....	94
Alternator.....	94
Radiator Cooling Fan.....	97
Battery power.....	98
Fuel Pump .....	99
OBD 2 Port .....	100
Start power.....	101
Tach .....	105
Autometer gauges .....	105
FFR vintage gauges.....	106
Oil Pressure and Water temp sensors.....	110
Clutch cable .....	111
Exhaust.....	112
O <sub>2</sub> Harness .....	112
Starting the engine .....	116

## Parts needed

### Ford Performance Parts

M-6007-M50C - 5.0L Engine  
M-6017-M50B - 2018 newer 5.0L engine control pack  
M-7003-R58C - TKO transmission  
M-7771-A - Bellhousing bolt kit  
M-9680-M50B - 5.0L engine cover kit  
M-7007-A – Starter Index plate  
M-6392-M46 - Bellhousing  
M-6375-G46A - Flywheel  
M-6397-B46 - Clutch bolt kit  
M-8600-M50BALT - 5.0 Alternator Kit

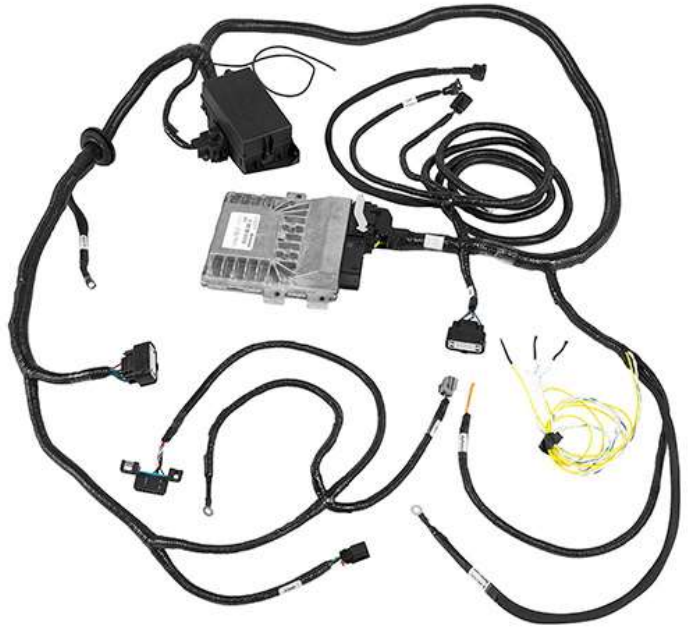

### Ford Motor Co. Parts

F3LY-6C070-A - Flywheel access hole plug  
W500310.S438 - Starter bolts (3 needed)  
BR3Z-6379-A - Flywheel bolt (8 needed)  
AL3Z-6890-A - Oil filter nipple to eliminate oil cooler spacer plate.  
GR3Z-11002-A - 2016 Starter.  
BR3Z-6710-A – Oil pan gasket

### Summit Racing

Clutch kit  
Clutch fork – If using cable clutch

### FUEL SYSTEM

👉 Ford Performance does not recommend the Corvette fuel filter/pressure regulator

AEI-13129 – 6AN Fuel pressure regulator  
SUM-220166B – 6AN O-ring to straight 6AN Adapter (2 needed)  
SUM-220701-B – 6AN to -6AN Hose Barb (1 needed)  
FRA-495110-BL – 6AN O-ring to straight -4AN Adapter (1 needed)  
SUM-220700-B – 4AN Hose Barb (1 needed)  
SUM-220711-B – 90° -6AN to -6AN Hose Barb (1 needed)  
SUM-800199 – 0-100 EFI fuel pressure gauge  
GSL392BX – Fuel Pump or VOR-8F002-265 Fuel pump  
VPN-400-939 – Fuel pump mount/barbs for GSL392BX pump

### AIR INTAKE SYSTEM

[www.treadstoneperformance.com](http://www.treadstoneperformance.com) – MAPHL4 or FFR 16941  
FFR 16942 - 90° Silicone hose with fittings  
FFR 16975 - Air filter

### Other vendors

Oil pan bolts – M6 x 20mm

Hydraulic throw-out bearing – if using a Hydraulic clutch

## AUTOZONE

Oil pan sensor plug – Dorman 65221

Morosso – Oil Pan (Coyote #20570 and pickup #24577)

Autometer Tach Adapter 9117 (Only if using Autometer Gauges)

Hoses and fittings for Vacuum lines

## Supplies

Oil – See instructions with engine - 8 quart

Coolant –2-3 gallons of **Dex-Cool concentrate**

Transmission fluid

Teflon tape



## Information

- ✎ These instructions are for Gen 3 2018+ Coyote engines only. If using an older Coyote, download those instructions from [www.parts.factoryfive.com/instructions](http://www.parts.factoryfive.com/instructions) .
- ✎ These instructions assume that the customer has the Roadster Coyote Installation kit from Factory Five Racing.
- ✎ Make sure to download the latest version of the engine controls instructions from the Ford Performance parts website: [www.performanceparts.ford.com](http://www.performanceparts.ford.com). Do a parts search for: M-6017-M50B and click on the instructions pdf.
- ✎ The ECU has a base tune, it is strongly recommended to have the car dyno tuned after completion.

Use the following diagram as a guide for harness locations.

1	Fan wire
2	Engine starter
3	Engine computer
4	Fuse
5	Black fuse box
6	OBD 2 port
7	Accelerator pedal
8	Engine connection
9	Clutch switch

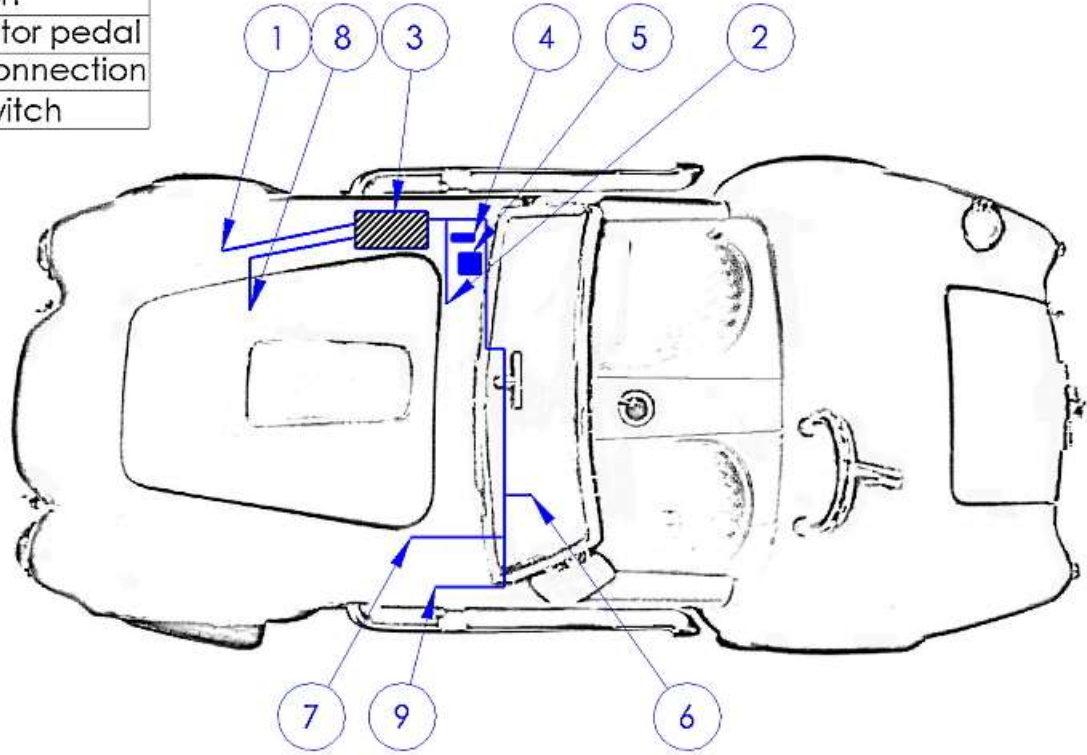

Wiring layout

## Accelerator Pedal

- ✂ Hack saw, T-25 Torx bit, ratchet,  $\frac{7}{16}$ " wrench, silver Marker, Grinder or drill bit, clamp
- 🛠 Accelerator pedal, coyote accelerator install kit

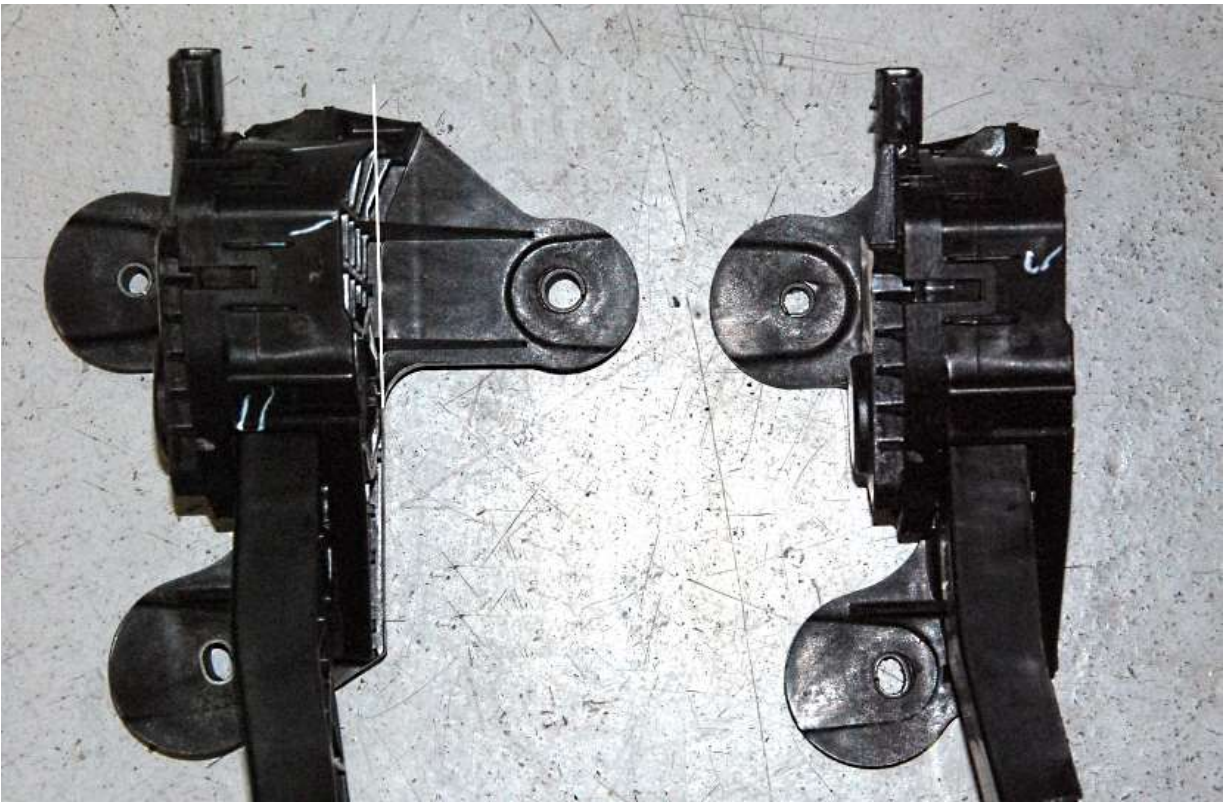

Use a hack saw to cut the right mount off the accelerator. Cut right against the flat section of the pedal so it also cuts the top Webbing off.





Turn the pedal pad around using the same screw hole.



Mark the pedal where the pad stops.



Cut the pedal with a hack saw then screw the pad back on.

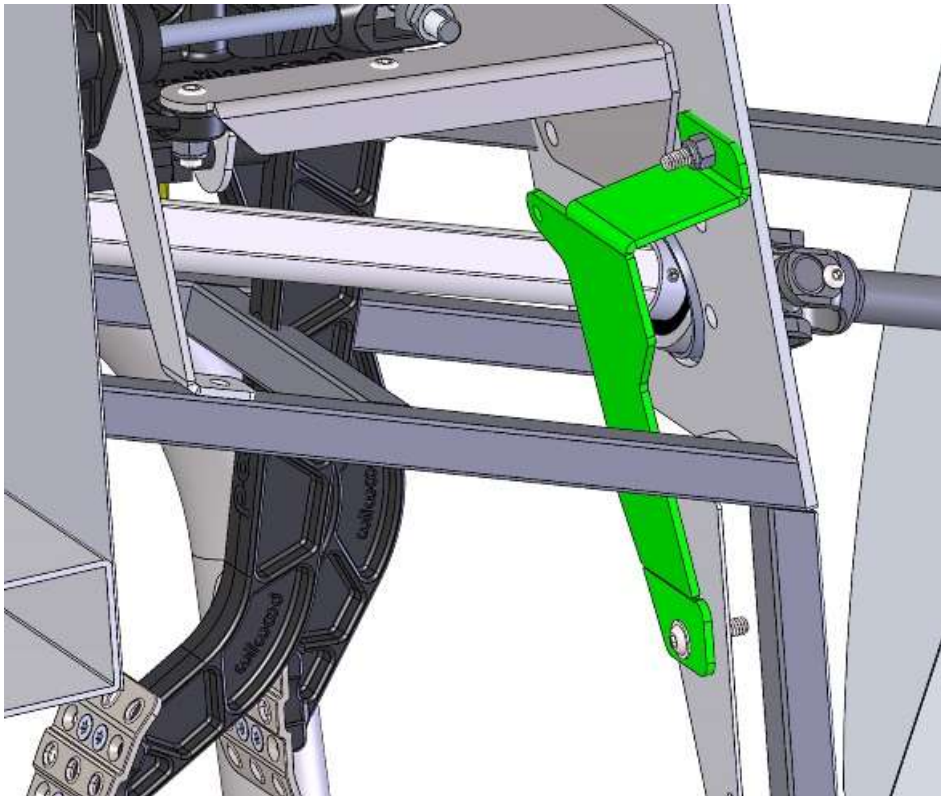

Attach the Accelerator pedal mount to the frame accelerator pedal mount using the 1/4" flange head screws, the top hole will have to be drilled through the aluminum from the inside using the front plate hole as a guide.



Mount the accelerator pedal using the remaining ¼" fasteners.

## Fuel pressure regulator



Decide where you would like to mount a fuel pressure regulator; on the firewall or the underside of the 2"x 2" tube depending on its mount.



Use a piece of tape to locate the mounting holes and make sure the regulator is not crooked then drill mounting holes.



Attach the regulator to the firewall.



Connect the appropriate fittings, the return is on the bottom.



Push the  $\frac{3}{8}$ " fuel line onto the right side of the regulator then attach a hose clamp and run it over to the engine fuel rail.

# Drivetrain

## Engine prep

- ✂ 6mm, 10mm, 13mm, 15mm 19mm sockets, 13mm deep socket, ratchet
- 🔧 Ford Racing, pipe fittings, Shallow oil pan
- 👤 Do not put the alternator on until after the engine is in.

## Flywheel



Use a 19mm socket and impact wrench to remove the flywheel that comes with the engine, it is not the correct type for the transmission used.

Discard the flywheel and bolts.

## Exhaust





Remove the Stock Mustang header.



Remove all of the header studs using a 6mm 6 point socket.

## Oil System

-  Morosso Oil pan, Oil pan sensor plug
-  Ratchet,  $\frac{3}{8}$ " hex key or socket, ratchet

- ✎ Blow the oil pan and pick-up out before assembling the pan to the engine to make sure there is nothing in them.

Use an engine hoist to lift the engine up off the shipping pallet.

## **OIL COOLER**

- ✎ This cooler is too long and will not be used again.



Place a bucket or container to catch oil under the filter, remove the oil filter and save for later.



Use an H14 hex key to remove the oil filter nipple and cooler. These will not be used again.



Insert the AL3Z-6890-A oil filter nipple.



Use the H14 Hex key to tighten the nipple in the block.



Reattach the oil filter.

## OIL PAN



Drain the oil from the engine.

## New pan prep



Screw the oil pan sensor plug into the pan with the gasket on the plug.



Put Teflon tape onto the plugs included with the oil pan.



Screw the plugs into the oil pan using a  $\frac{3}{8}$ " hex and ratchet.

## Pan removal



Use a 10mm socket to remove all of oil pan bolts.



Remove the oil pan.

## Oil pick-up

- 👉 Follow the Morosso instructions, the following are more pictures of the removal and install.
- 🔧 15mm deep socket, torque wrench, flathead screwdriver, ratchet, drill,  $\frac{7}{16}$ " drill bit.

Remove the old oil pump pick-up.

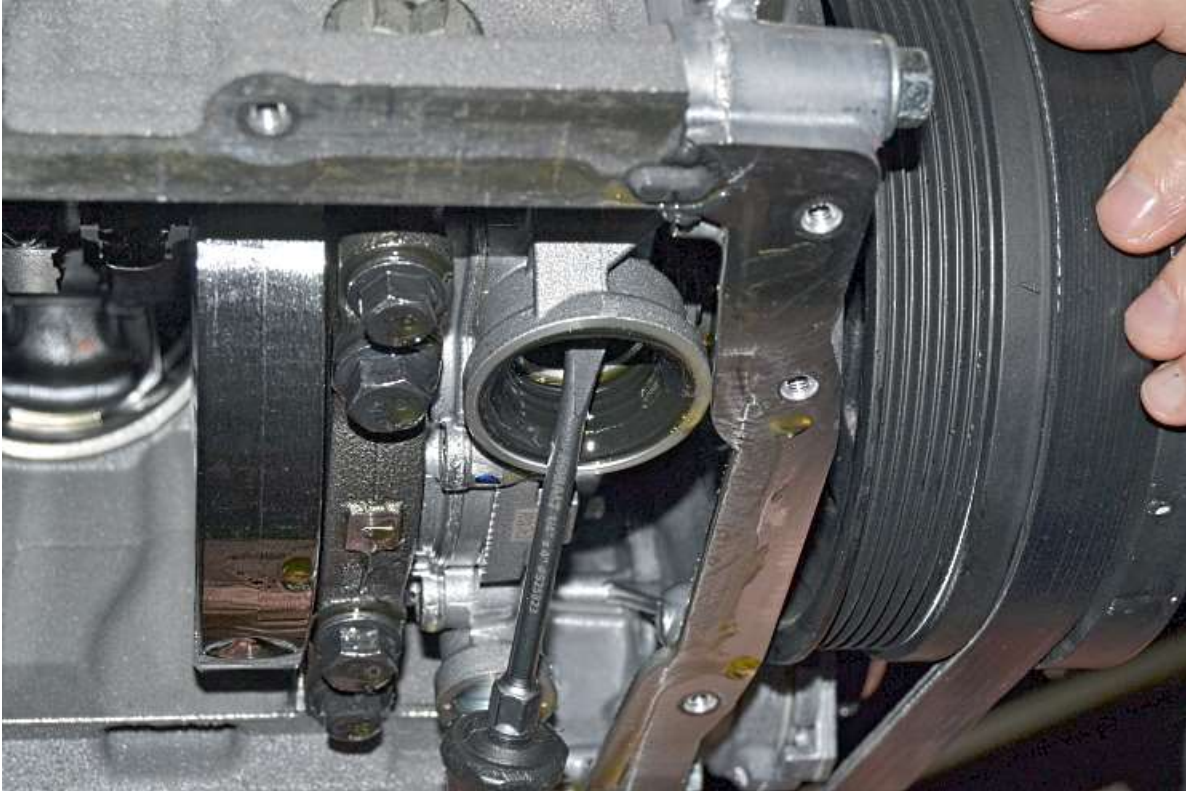

Use a flathead screwdriver to remove the old pick-up O-ring from the oil pump.



On the new pick-up, open the mounting hole on the welded bracket up to  $\frac{7}{16}$ ".



Put the O-ring included with the new pick-up onto the pick-up.



Remove the correct main cap bolt shown in the instructions using a 15mm socket.



Install the new main cap bolt with the threaded stud that is included with the pick-up and **torque to 48 Lbft (65Nm) + 90° turn.**

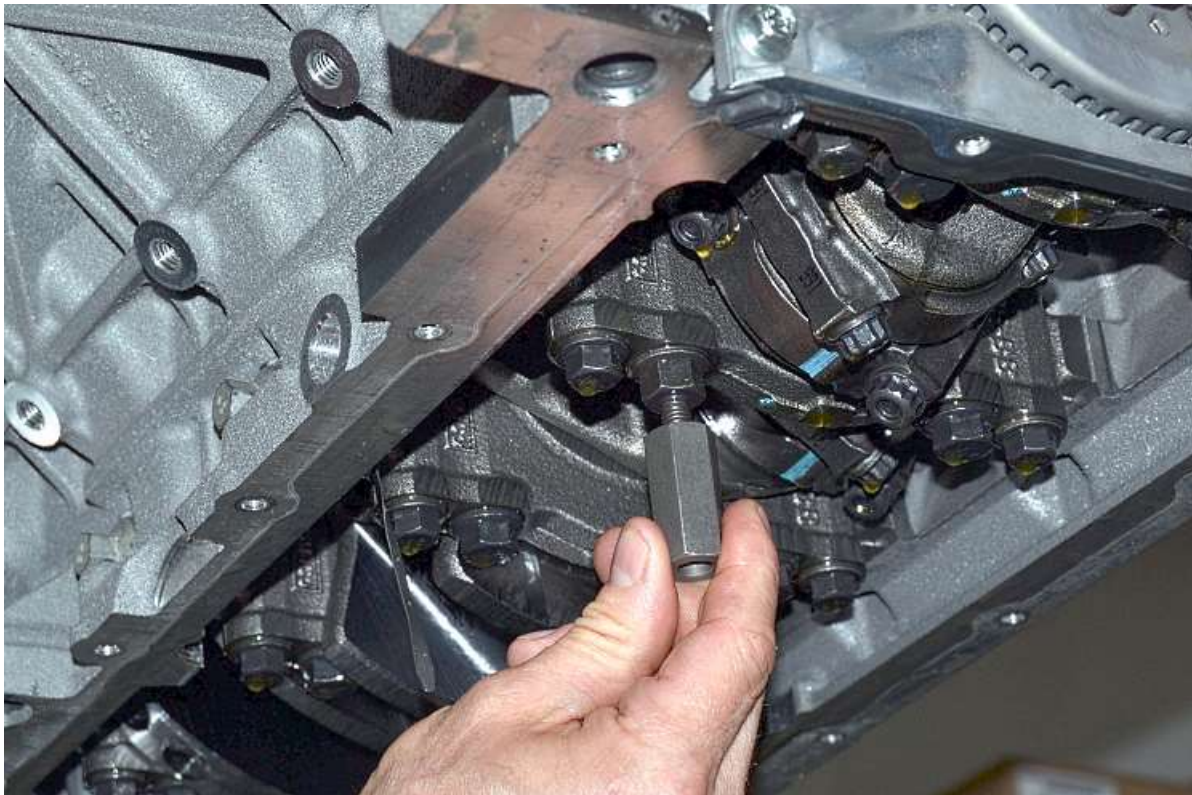

Screw the oil pick-up spacer onto the threaded stud and **torque to 20lbft (27Nm)**.



Hold the new oil pan gasket/windage tray up to the block and hold in place with a couple of oil pan bolts.



Apply some engine oil to the new pick-up O-ring.



Insert the pick-up into the pump through the windage tray, you may need to use a flathead screwdriver and plastic hammer on the pick-up flange on the pump so that it fully seats.



Attach the pick-up to the spacer using a 13mm wrench or socket and **torque to 20lbft (27Nm)**.

👉 The next step is easier with two people.



Remove the oil pan screws holding the windage tray up.



Hold the oil pan up to the block and thread all of the new bolts in by hand.

Torque all of the accessible oil pan bolts to **10 Nm +45 deg.**



For the bolts over the oil pan bump outs, use a wrench. Get the “feel” of the 10Nm by using the wrench on one of the correctly torqued bolts first then try to match this on the bolts not torqued.

## New flywheel/clutch

- 🔧 Flywheel, clutch set w/thrust bearing
- 🔨 Hammer, torque wrench, 19mm, 7/8" sockets, rag, brake cleaner.



Remove the vertical 2"x 4" perimeter frame on the pallet



Set the engine down on the pallet so that the back of the oil pan is flush with the edge of the pallet.



Use a hammer and 7/8" or 22mm socket to hit the thrust bearing into the back side of the crank.

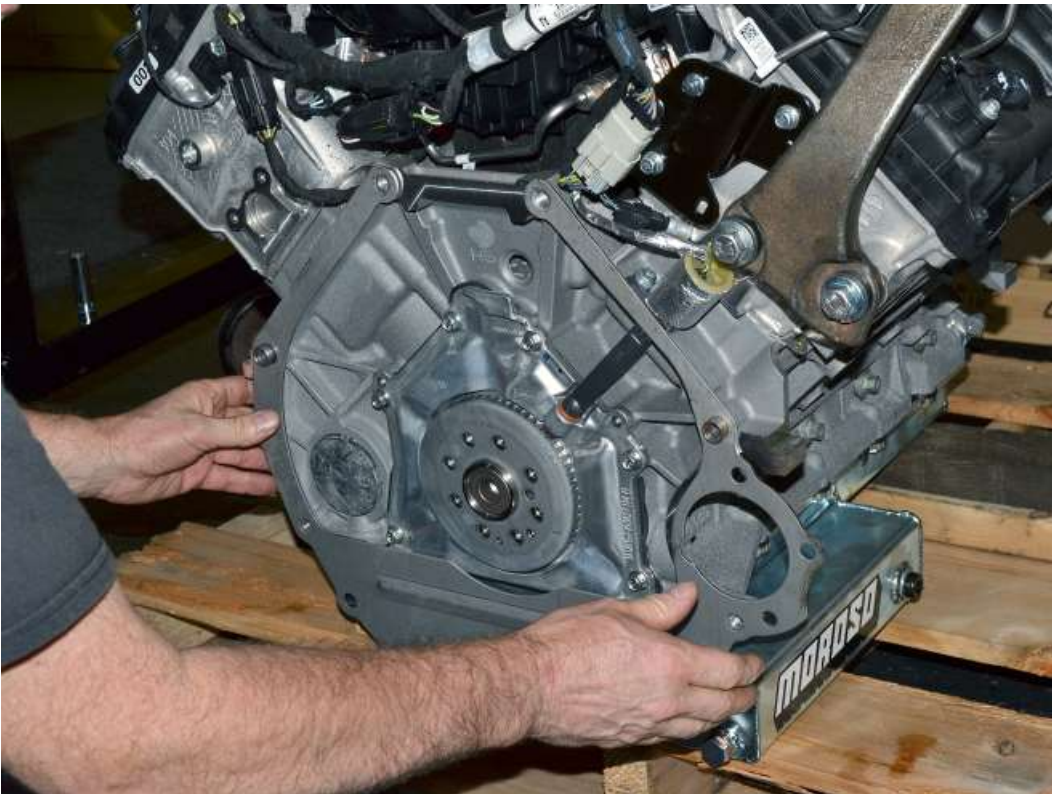

Put the inspection plate on the back of the engine.



Use a hammer to hit the clutch pins into the new flywheel.



Wipe the flywheel surface off with brake cleaner.

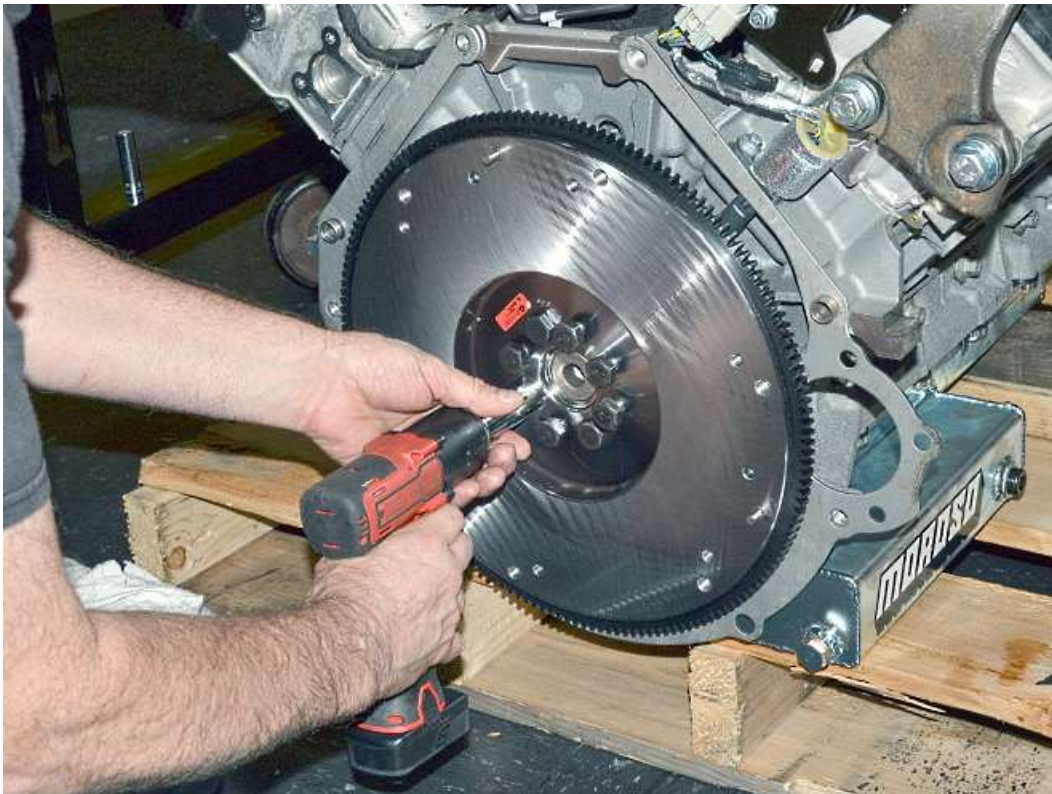

Attach the flywheel to the engine with a 19mm socket.



Use a screwdriver or punch through the flywheel into the starter opening of the inspection plate to stop the flywheel from turning while torquing the flywheel bolts to **80 Lbft.**

☞ We have found many of the aluminum bellhousings will hit the flywheel so it is important to check this in the next few steps otherwise the engine will not turn over.



Attach the bellhousing to the engine using a couple of the bellhousing bolts.



Look inside the bellhousing just above the clutch fork hole or try to turn the engine over using the crank bolt.



These marks show the interference of the flywheel and bellhousing.



Remove the bellhousing and use a grinder or file to remove material where the flywheel hits.



Use some engine oil to lubricate the thrust bearing. Make sure the oil does not leak down onto the clutch surface.



Put the clutch disc on with the alignment tool.



Put the pressure plate on the flywheel and torque the bolts to **35 Lbft** using a torque wrench.

Attach the pivot stud to the inside of the bellhousing using Loctite.  
Attach the clutch fork to the bellhousing.



Attach the bellhousing to the engine and **torque to 35 Lbft**.

## TORQUE SPECS

FLYWHEEL TO CRANK	80	Lbft
PRESSURE PLATE TO FLYWHEEL	35	Lbft
BELLOUSING TO ENGINE	35	Lbft

## Engine mounts

- 🛠 Engine mounts, Engine mount spacers, M10 x 25mm bolts,  $\frac{3}{8}$ " x 1.50" carriage bolts
- 🔧  $\frac{9}{16}$ ", 17mm sockets, ratchet, hammer.

Use a  $\frac{9}{16}$ " socket and ratchet to remove the three locknuts on each of the engine mounts and save them. Use a hammer to remove the three carriage bolts from the bottom engine mount plates. They are not used again.

ITEM NO.	PART NUMBER	DESCRIPTION	QTY.
1	4.6L left side top mount		1
2	4.6L left side bottom mount		1
3	16249	COYOTE ENGINE MOUNT 2 HOLE SPACER	1
4	16250	COYOTE ENGINE MOUNT 1 HOLE SPACER	1
5	16251	COYOTE ENGINE MOUNT 3 HOLE SPACER	1
6	RHSSNBOLT0.375-16x1.5x1-N		3
7	13964	NYLON INSERT LOCKNUT, 3/8-16 UNC	3
8	AM-M14-N		1

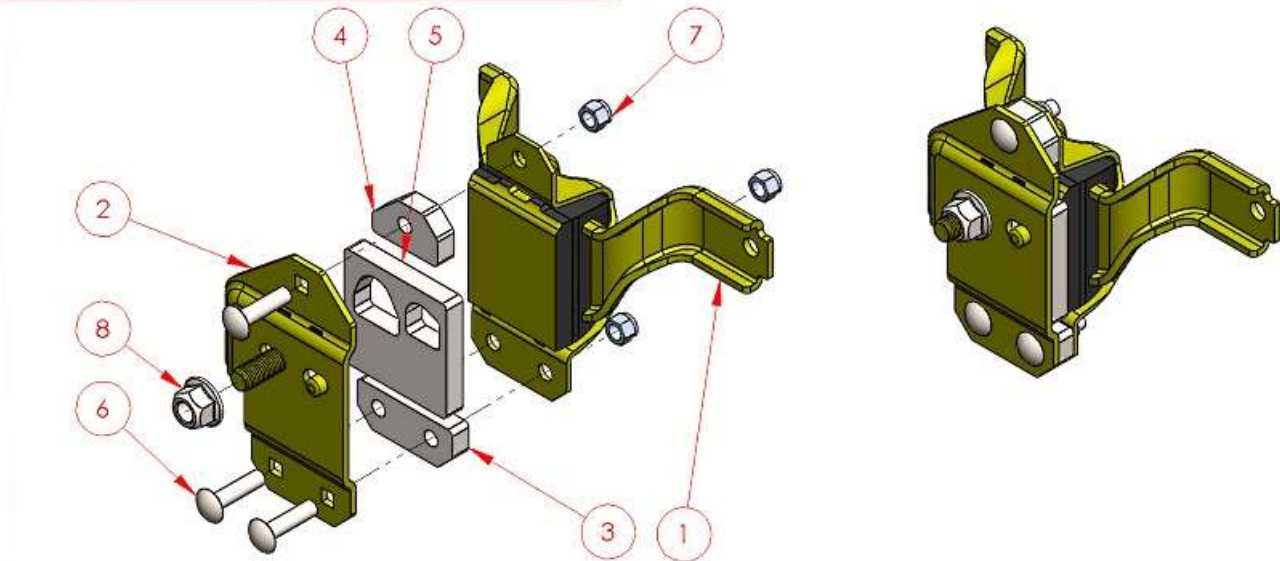

Reassemble the left engine mount using the  $\frac{1}{2}$ " thick spacers,  $\frac{3}{8}$ " x 1.50" carriage bolts and a  $\frac{9}{16}$ " socket with ratchet. Reuse the  $\frac{3}{8}$ " locknuts.

ITEM NO.	PART NUMBER	DESCRIPTION	QTY.
1	16249	COYOTE ENGINE MOUNT 2 HOLE SPACER	1
2	16250	COYOTE ENGINE MOUNT 1 HOLE SPACER	1
3	16251	COYOTE ENGINE MOUNT LARGE SPACER	1
4	4.6L right side bottom mount		1
5	4.6L right side top mount		1
6	AMMI 4-N		1
7	RHSNBOLT 0.375-1.6x1.5x1-N	16264	3
8	13964	NYLON INSERT LOCKNUT, 3/8-16 UNC	3

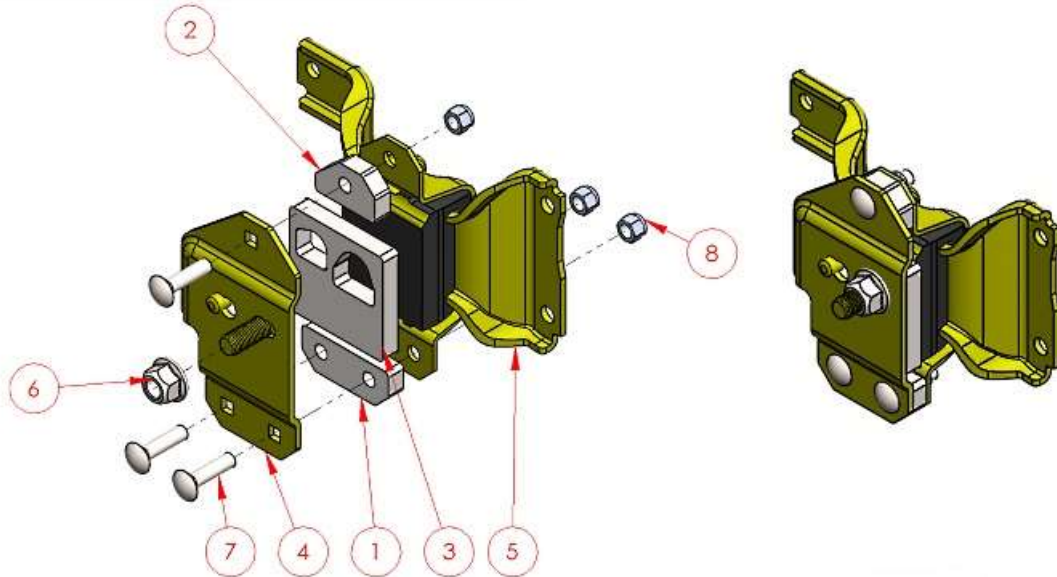

Reassemble the right engine mount using the 1/2" thick spacers, 3/8"x 1.50" carriage bolts and a 9/16" socket with ratchet. Reuse the 3/8" locknuts.



Attach the engine mounts to the engine using the M10 x 25mm bolts provided with the engine mounts and a 17mm socket with ratchet. Don't forget to attach the engine ground strap to a right-side engine mount bolt.

## Starter



Attach the starter to the engine and torque the fasteners to **15-20Lbft. (25Nm)**.



Spin the small locknut onto the small post and the flange nut onto the large post.

## Oil Pressure sender

✂  $\frac{15}{16}$ " wrench



Remove the stock oil pressure gauge sender plug from the block located on the left front side of the engine.



Remove the wiring harness connector above the sending unit.

- 👤 The oil pressure sender will get installed after the water temp sender is installed.
- 👤 The Stock oil pressure sender is still needed for the best computer operation.

## Water Temp Sender

- 🔧 H14 Hex key or socket, 1 1/16" socket, 7/8", 12mm deep socket, extension, ratchet, Teflon tape
- 🚗 Water temp gauge sending unit.
- 👤 Autometer gauge sender shown, similar install for Vintage gauge sender.



Remove the 3/4" NPT plug from the side of the block using a H14 Hex key.



Use Teflon tape on the  $\frac{1}{8}$ " NPT to  $\frac{1}{2}$ " NPT adapter included with the gauge.



Use a vise to hold the large  $\frac{3}{4}$ " to  $\frac{1}{2}$ " NPT adapter then use a  $\frac{7}{8}$ " wrench to put the two adapters together.

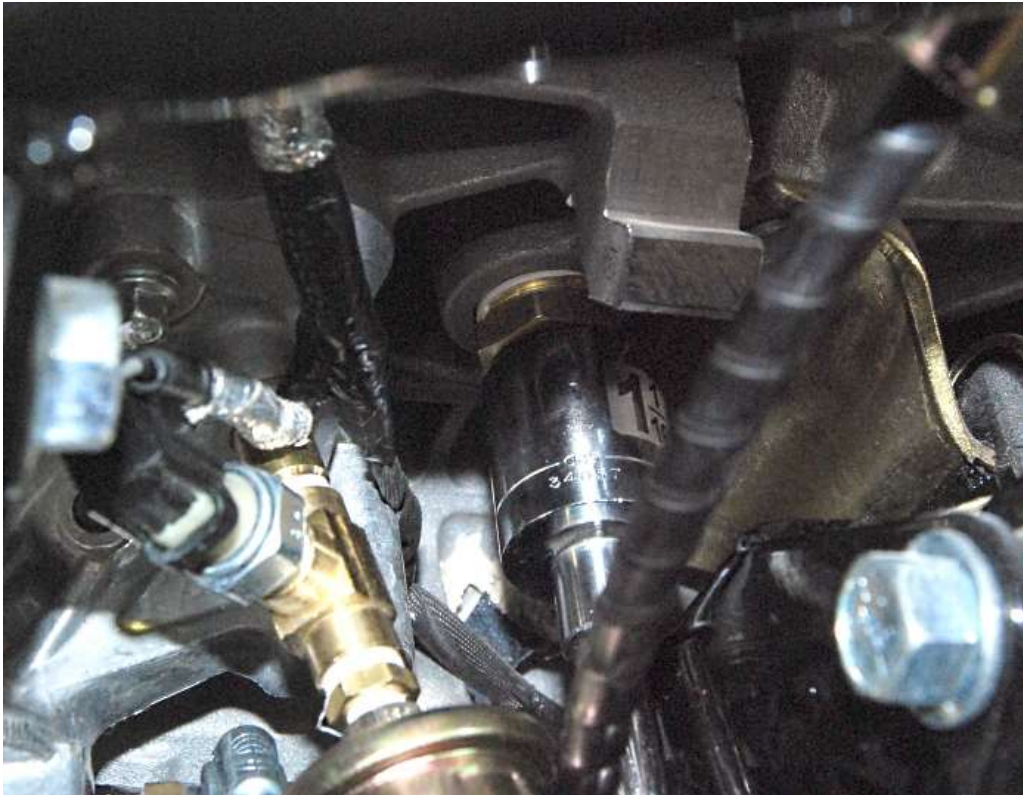

Screw the adapter into the block using a 1 1/16" socket.



Screw the adapter into the larger adapter on the block.



Put Teflon tape on the sending unit Autometer top, Vintage bottom



Use a 3/4" wrench to screw the sender into the adapters.

## Oil pressure sender

- ✂  $\frac{3}{4}$ ",  $\frac{15}{16}$ " wrenches, Teflon tape
- 🔧 NPT adapter fittings, OE stock sender, Gauges oil pressure sender.

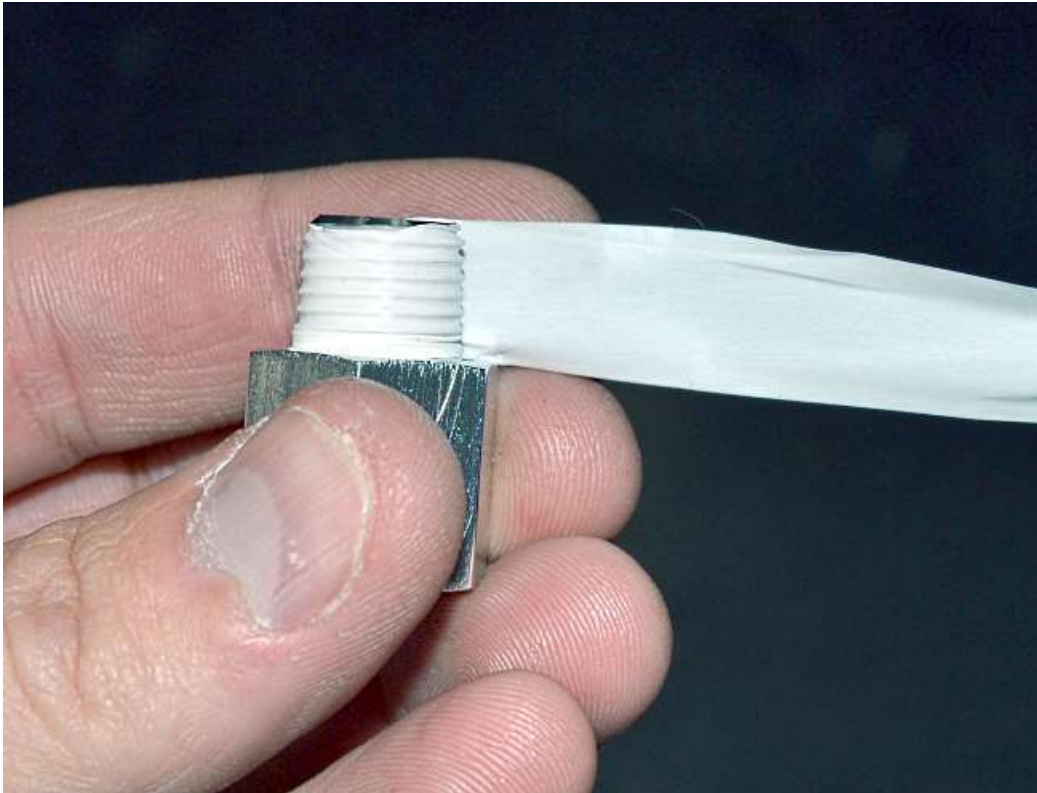

Put Teflon tape on both adapters and the brass "T".

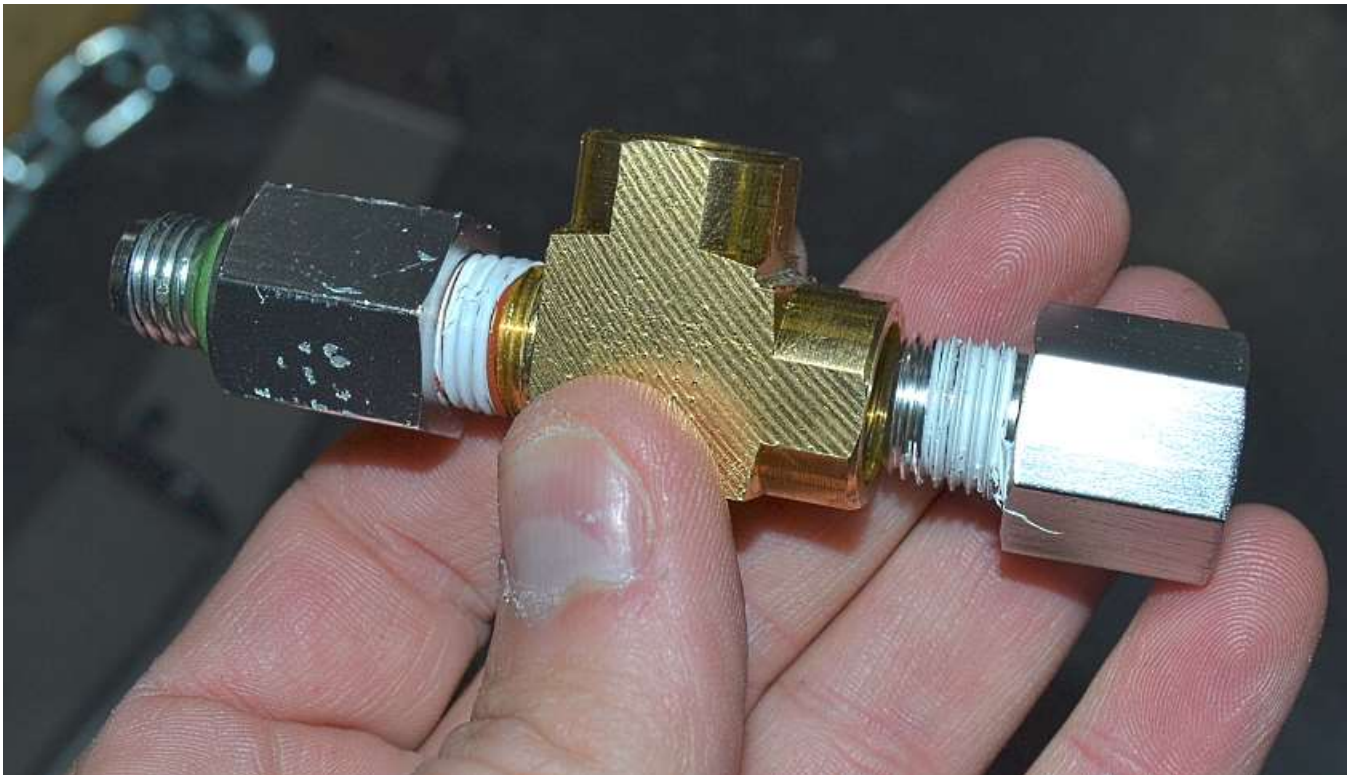

Connect and tighten the three adapters together.



Using a  $\frac{3}{4}$ " wrench, screw the adapters into the block where the stock sender was making sure to have the brass T pointed up or back so that the sender will clear the alternator.



Thread and tighten the stock oil pressure sender in the end of the adapters with a  $\frac{15}{16}$ " wrench.



Screw the gauge sender (Vintage gauge sender with adapters shown) into the side of the “T” adapter.

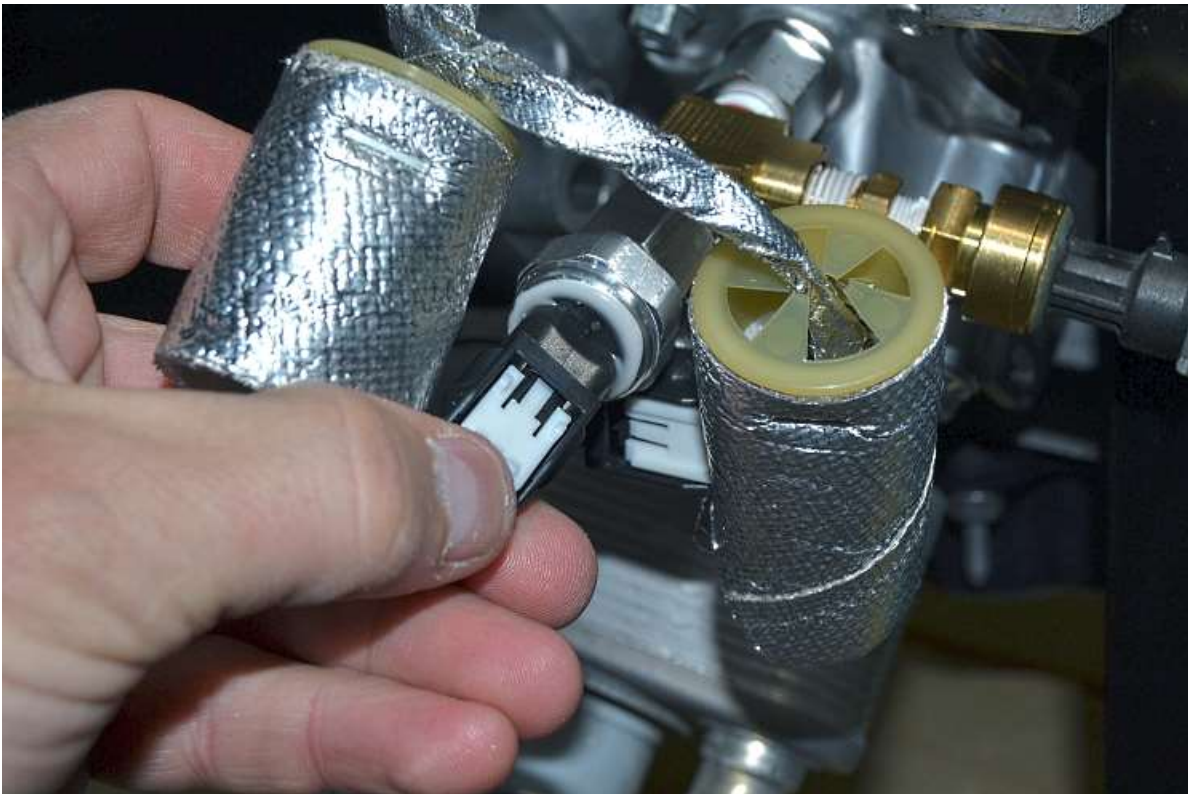

Attach the wiring connector back to the OE sender.



Push the cover back onto the stock sending unit.



Reattach the wiring harness to the block above the sending units.

## Transmission Prep

- ✂ Hack saw or Reciprocating saw,  $\frac{3}{4}$ " socket, ratchet
- 🛠 Transmission, Polyurethane engine/transmission mount kit.



15mm socket,  $\frac{5}{8}$ " ,  $\frac{3}{4}$ " socket, ratchet,  $\frac{3}{4}$ " wrench.

The FFR Coupe **does not** need the boss cut off the transmission.



If you are using a Tremec TKO 500 or, a TKO 600 you will need to trim off the unused mounting boss on the bottom of the case.



Trim it flush or just below the pad for the transmission mount.

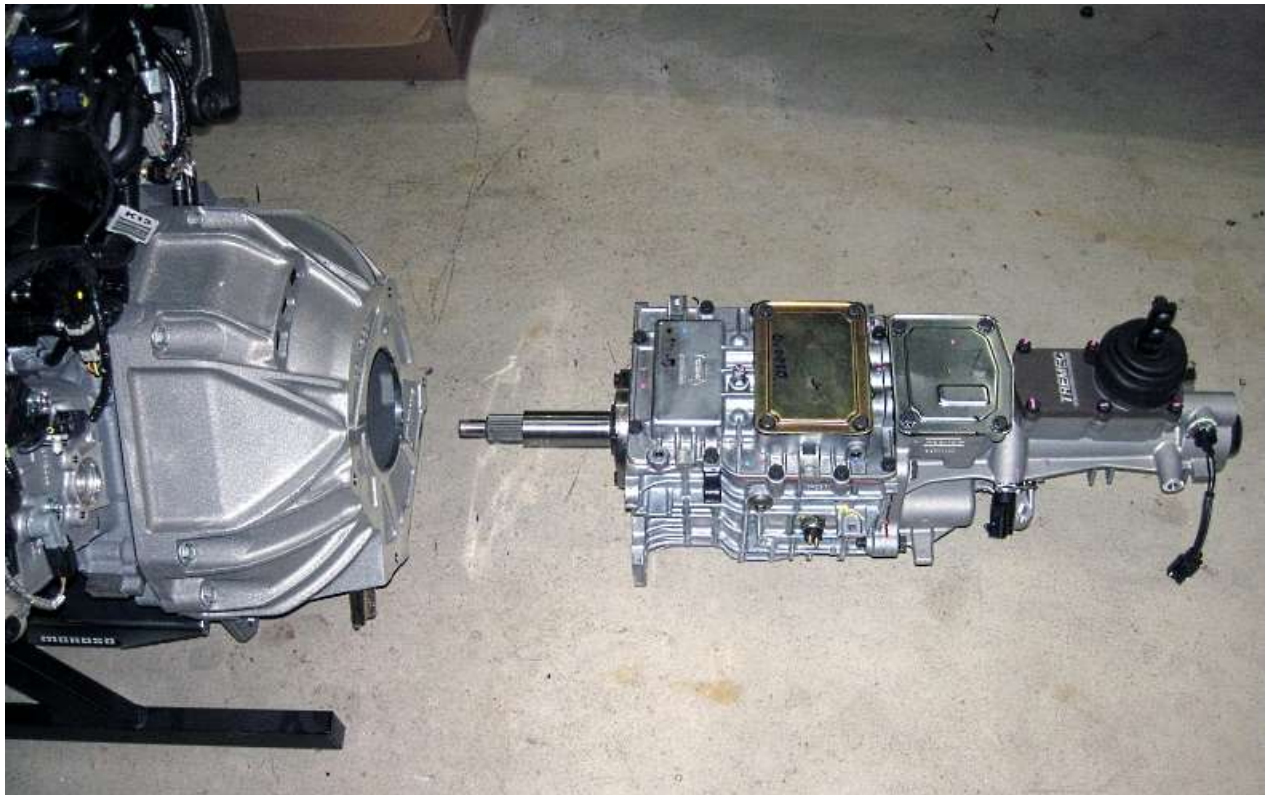

Attach the transmission to the bellhousing. Torque the bolts to **50lbft.**

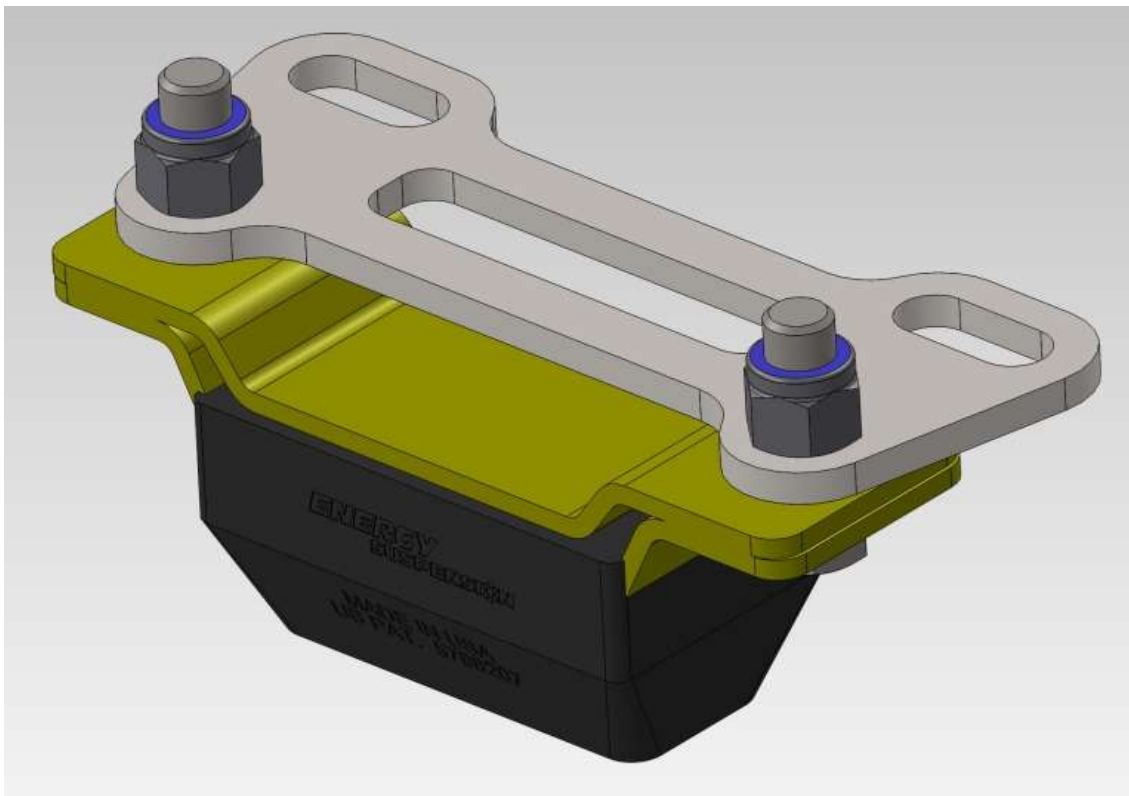

Attach the transmission mount plate to the polyurethane transmission mount using the ½”-13 x 1.50” bolts.

## Engine/Transmission Installation

Install the engine and transmission per the assembly manual.



The engine will sit low in the engine mounts.

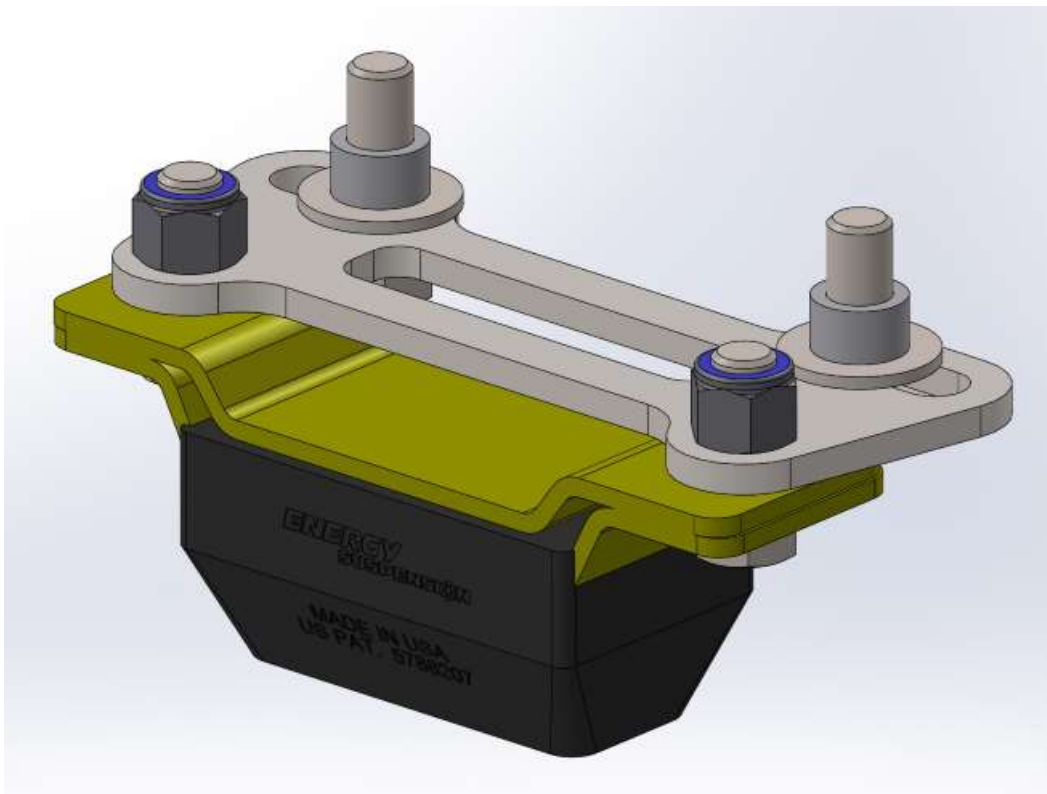

Attach the polyurethane transmission mount assembly to the transmission using the 0.40" spacers, washers and 1/2" x 1.50" bolts and 3/4" socket.

Attach the polyurethane transmission mount to the frame mount using a 5/8" socket.

## Alternator

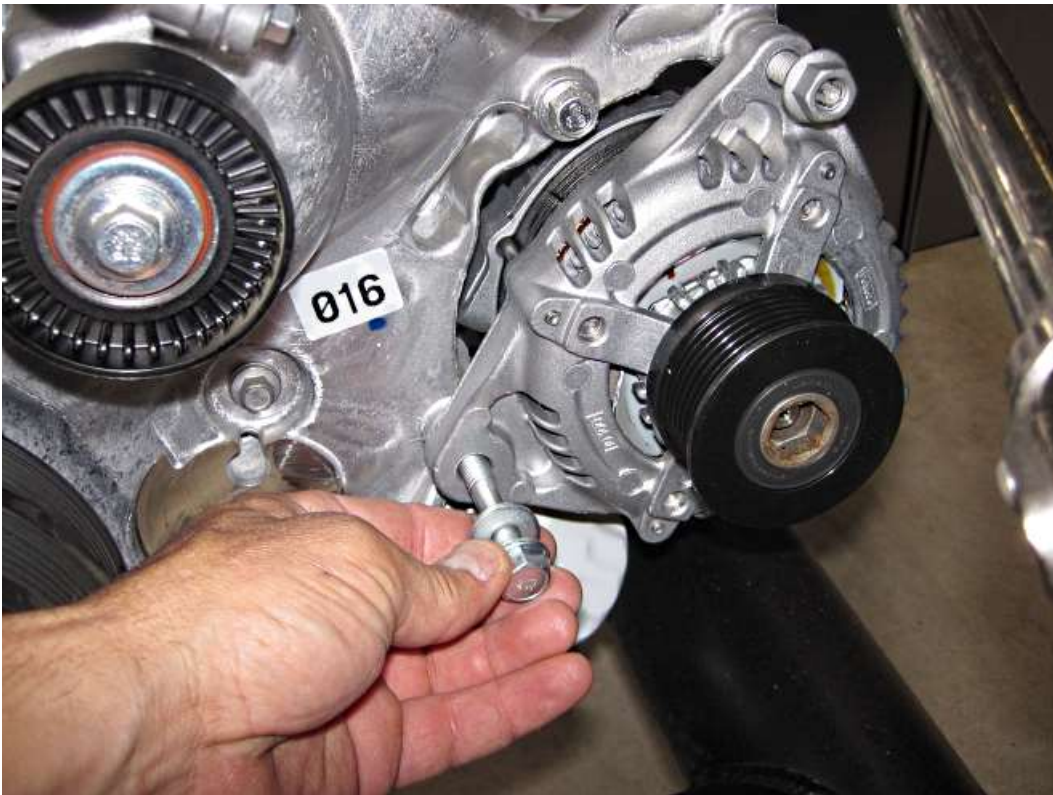

Attach the alternator first and torque the fasteners per the Ford Performance instructions.



Attach the tensioner and torque the fasteners per the Ford Performance instructions.

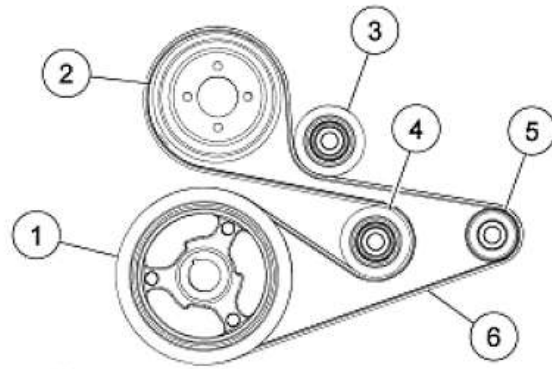

Item	Description
1	Crankshaft pulley (on engine)
2	Coolant pump pulley (on engine)
3	Accessory drive belt idler pulley (on engine)
4	Accessory drive belt tensioner pulley
5	Alternator and pulley
6	Accessory drive belt

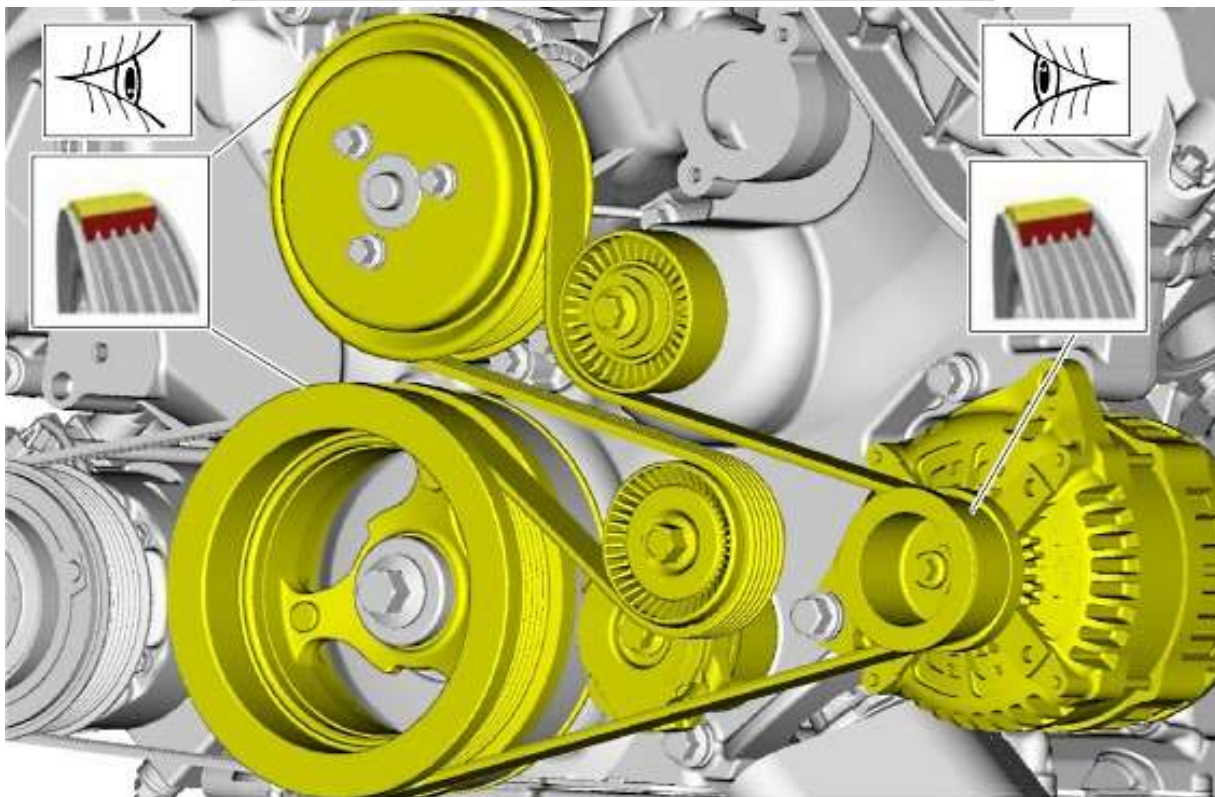

Route and install the serpentine belt.

## Shifter handle



The Factory Five Coyote install kit includes a short shifter handle that can be used.





Sit in the driver seat and decide how you want to hold and shift the shifter handle, we have found that with the Coyote transmission location a vertical shifter works better.



Drill a hole  $\frac{7}{8}$ " above the bottom hole on the handle. Start with a small  $\frac{1}{8}$ " bit and work your way up. The handle is forged so it is hard and will take a while.

The handle usually gets final mounted after the carpet is installed.

## Fuel System

-  Fuel pressure regulator, fittings, fuel hose, hose clamps, high pressure fuel pump
-  The Coyote engine requires a 255 lph high pressure fuel pump such as the Summit Racing SUM-G3138 Fuel Pump. Either an inline pump or in-tank pump can be used depending on preference.
-  Factory Five offers a complete fuel system for the Coyote including fuel pump, AN fuel lines, fittings, regulator and charcoal canister.

## Fuel lines



Push the white fuel line connector onto the fuel rail.

Hold the fuel line up to the connector and cut it to length with a razor knife.

Remove the fuel line connector.

Slide a hose clamp onto the hose then push the fuel line connector into the hose and tighten the clamp.



Push the white connector onto the fuel rail.

## Fuel pressure regulator vacuum



Push the 90° fitting with the small barb onto the smaller connection behind the throttle body.

Push the vacuum line onto the barb.



Run the vacuum line to the fuel pressure regulator then cut and push it onto vacuum barb.



Use one of the small kit zip ties to make sure there is a good seal on the regulator vacuum hose.

## Cooling system

✂ Razor knife, flat head screwdriver, wire cutters, hack saw, marker,  $\frac{5}{16}$ " socket, ratchet.

 Radiator hoses.

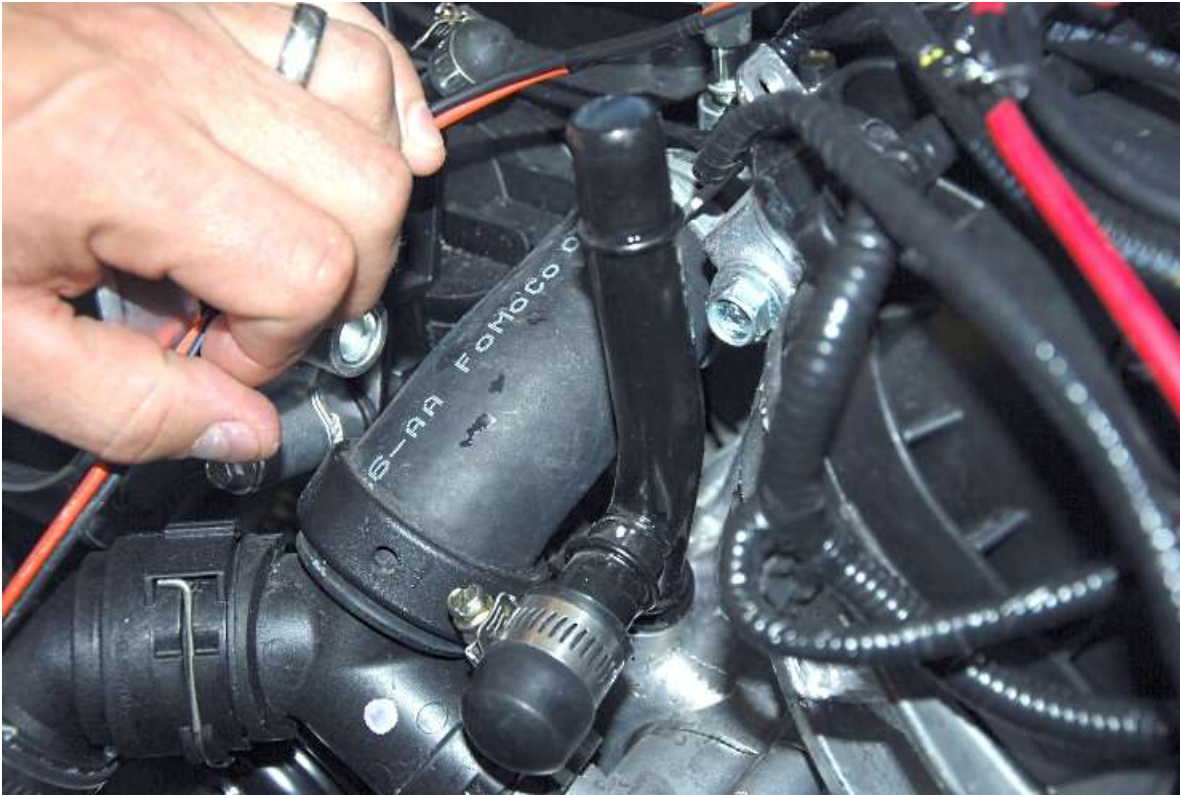

Push the  $\frac{3}{4}$ " bypass cap onto the lower tube to the left of the throttle body and hose clamp it.

### **LOWER HOSE**



Push 90 degree bend of the long radiator hose onto the thermostat housing.



Route the hose under the steering rack and over to the left side lower radiator outlet and mark the hose for cutting.

#### UPPER HOSE

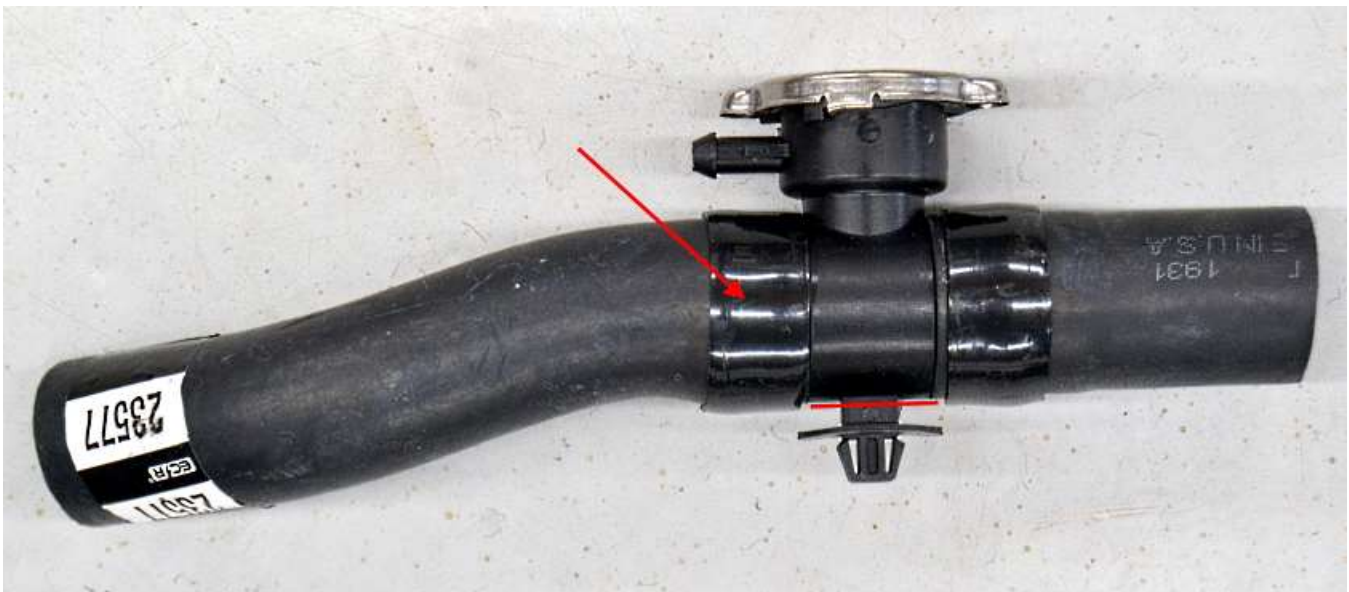

Locate the kit in-line filler assembly and cut the bottom plastic piece off along with a saw.

Use a razor knife to carefully cut the plastic clamp off the long tube side of the filler.



Push the inline filler onto the top radiator inlet making sure to have a hose clamp on the hose.



Push the Ford supplied hose onto the outlet under the throttle body.



Hold the hose up to the inline filler and decide where you would like to join them.

Cut the webbing off the hose where it will join using wire cutters or remove it completely.



Tighten the inline filler neck to the radiator.



Tighten the upper engine radiator hose to the inline filler.

#### **INTAKE AIR BLEED**



Push and hose clamp the small coolant barb behind the  $\frac{3}{4}$ " coolant tubes.

## HEATER CORE BYPASS HOSE

- ☞ If running a heater or A/C, do not push the spacer into the tube in the next step.
- ☞ If running a heater or A/C, this is the tube that the heater core would get plumbed into.

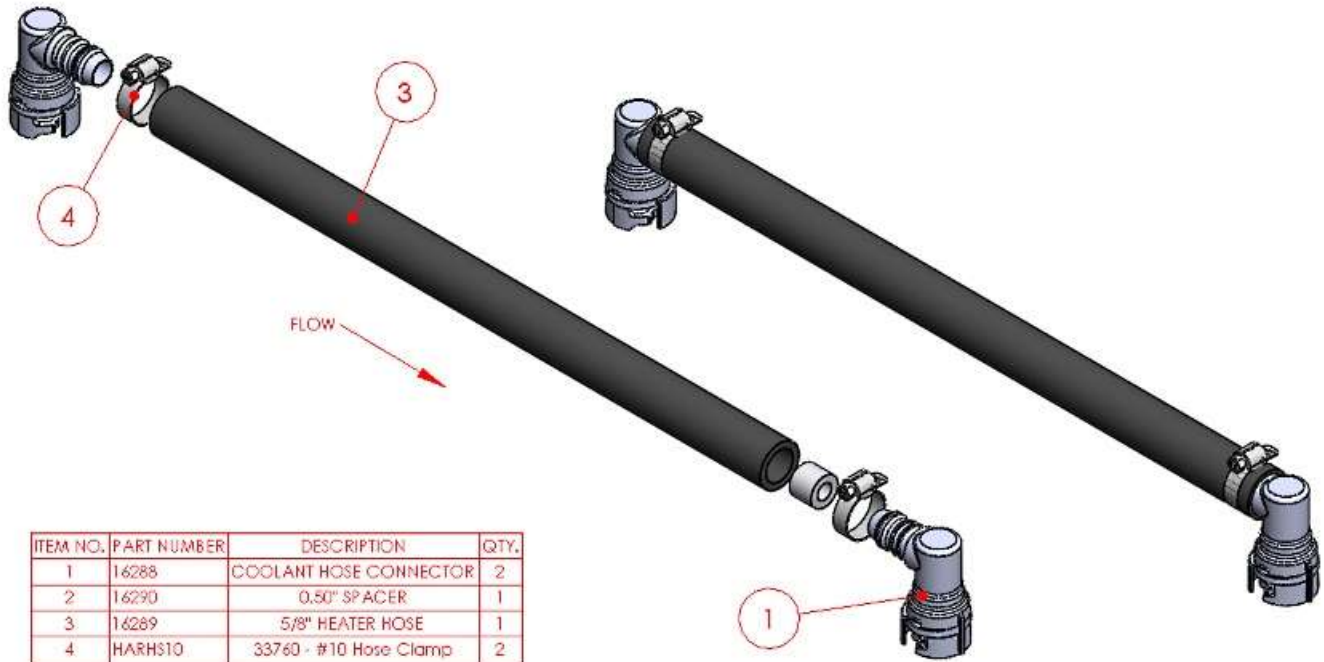

Assemble the right side of the heater bypass hose, insert the 0.50" aluminum spacer into the 5/8" heater hose followed by a hose clamp then push one of the 90° plastic coolant hose adapters.

Tighten the hose clamp using a 5/16" socket and ratchet.



Push the hose onto the top of the tube to the left of the throttle body.

Push the other adapter onto the tube on the right side of the intake then measure and cut the  $\frac{5}{8}$ " heater hose so that it will connect to the adapter and route where desired.



Put a hose clamp on the hose, push it onto the coolant adapter and tighten the hose clamp.

- ✎ For air bleeding later, remove the 90° plastic coolant hose adapter to the left of the throttle body until coolant starts going up the tube then recap and hose clamp.

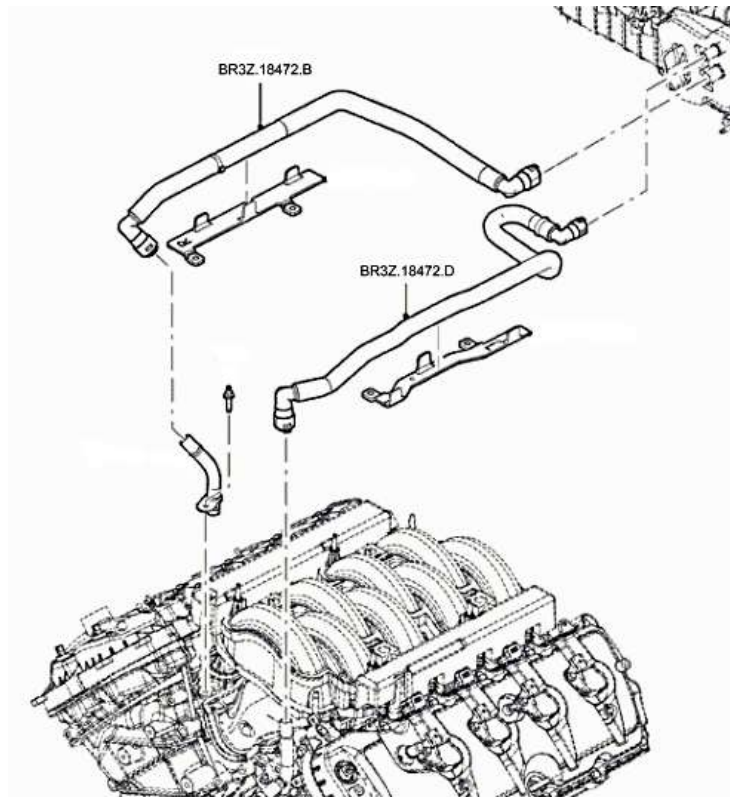

☞ If running a heater, use the bypass hose connectors and some heater hose to connect to the heater.

## Air Intake

### Mass Air Meter

- ☞ Mass air meter, silicone hoses, intake tubes, air filter
- ☞ T-20 Torx driver, Flat head screwdriver, Philips head screwdriver, sensor safe RTV silicone



Unscrew the mass air sensor from the Ford intake using a T-20 Torx driver



Remove the sensor and note the direction of the curved part of the sensor, on the engine side.



Install the sensor on the mount using the short screws so the flat side of the sensor will face the air filter.

## Intake tube



Make sure the Mass Air meter is pointed in the correct direction.



Push the FFR filter onto the Mass Air meter making sure that the meter is facing the correct direction.

Slide hose clamps onto the 90° Silicone hose.



Push the small end of the silicone hose onto the throttle body.

Push the mass air meter into the silicone hose.

Adjust the Mass air meter so that the mass air plug is on the side close to the engine as the Ford Performance instructions recommend.

Tighten the hose clamps.

## Vacuum ports and PCV vent

- ✂ Flat head screwdriver, razor knife, WD40
- 🛠 Vacuum plugs, PCV lines, ½” rubber hose, T connector



On the front of the intake manifold, push the  $\frac{3}{8}$ " Vacuum cap onto the vacuum barb.



Block off the  $\frac{1}{2}$ " large vacuum port just behind the throttle body.

## Valve cover hoses



If not already done, connect the right side stock PCV hose from the valve cover to behind the throttle body.





Attach the fitting to the left side valve cover.



Attach the other end of hose to the intake tube fitting.

## Clutch position switch

-  Ford Performance bottom travel switch, coyote clutch switch components.
-   $\frac{1}{2}$ " ,  $\frac{9}{16}$ " wrench,  $\frac{1}{2}$ " socket, Ratchet,  $\frac{3}{16}$ " ,  $\frac{5}{16}$ " hex keys.
-  The install is shown outside the footbox for better pictures.

### USING A CLUTCH CABLE

Remove the clutch cable from the quadrant.



On the clutch pedal, remove the last  $\frac{1}{8}$ " clutch quadrant end plate and replace it with the stainless bottom switch clutch quadrant plate.



Tighten the locknuts.

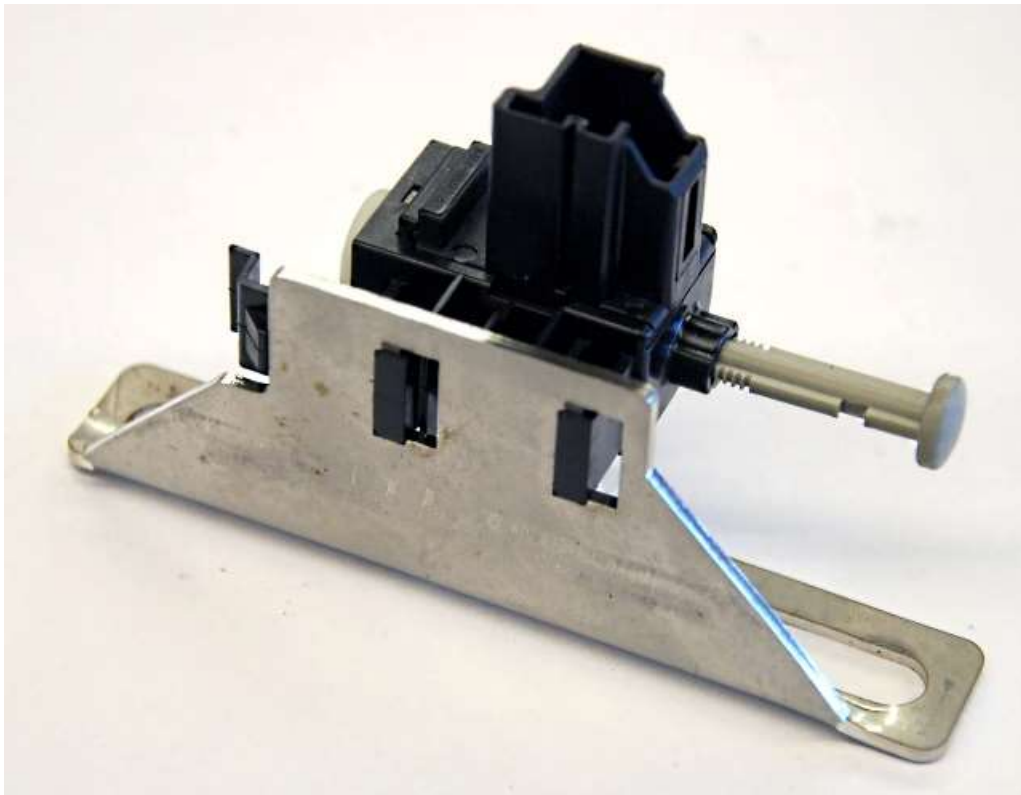

Attach the Bottom travel (gray plunger) clutch switch to the bottom travel switch mount as shown.

Remove the bolts holding the left side of the pedal box to the mount bracket.



Insert the new  $\frac{5}{16}$ " x 1.25" bolts through the bottom travel switch mount then through the pedal box bracket and pedal box.

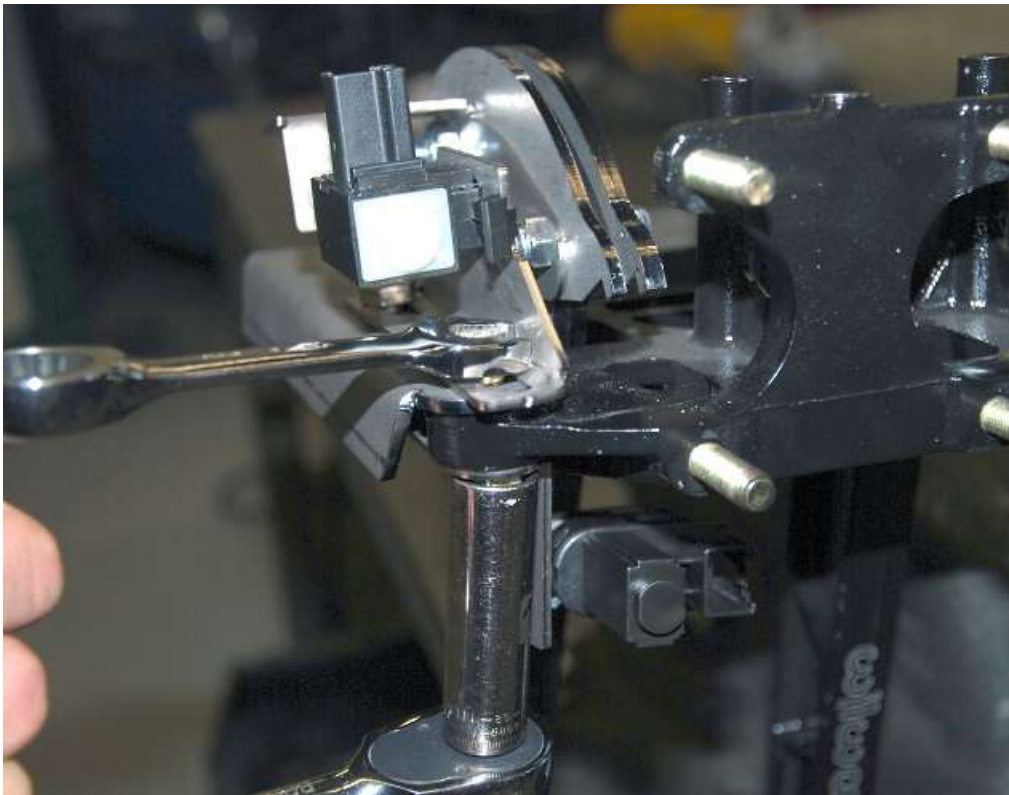

Snug the bolts up with a 1/2" wrench and socket so the bottom travel switch bracket can still move.

Reattach the clutch cable to the quadrant.

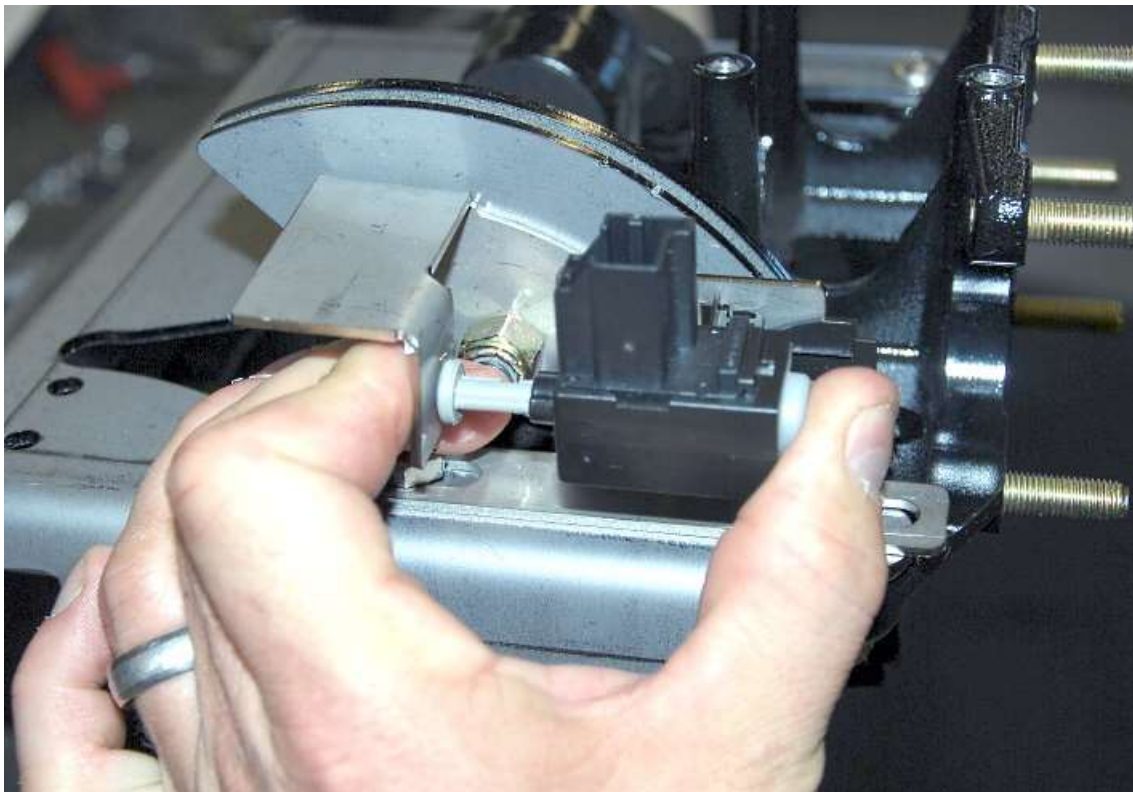

Have someone push the clutch pedal all the way in then slide the bottom travel switch mount so that the bottom travel switch is pressed in all the way against the quadrant plate. Hold the switch mount so that it

does not move and let the clutch out then tighten the pedalbox mount screws with a ½” wrench and socket making sure the switch mount does not move.

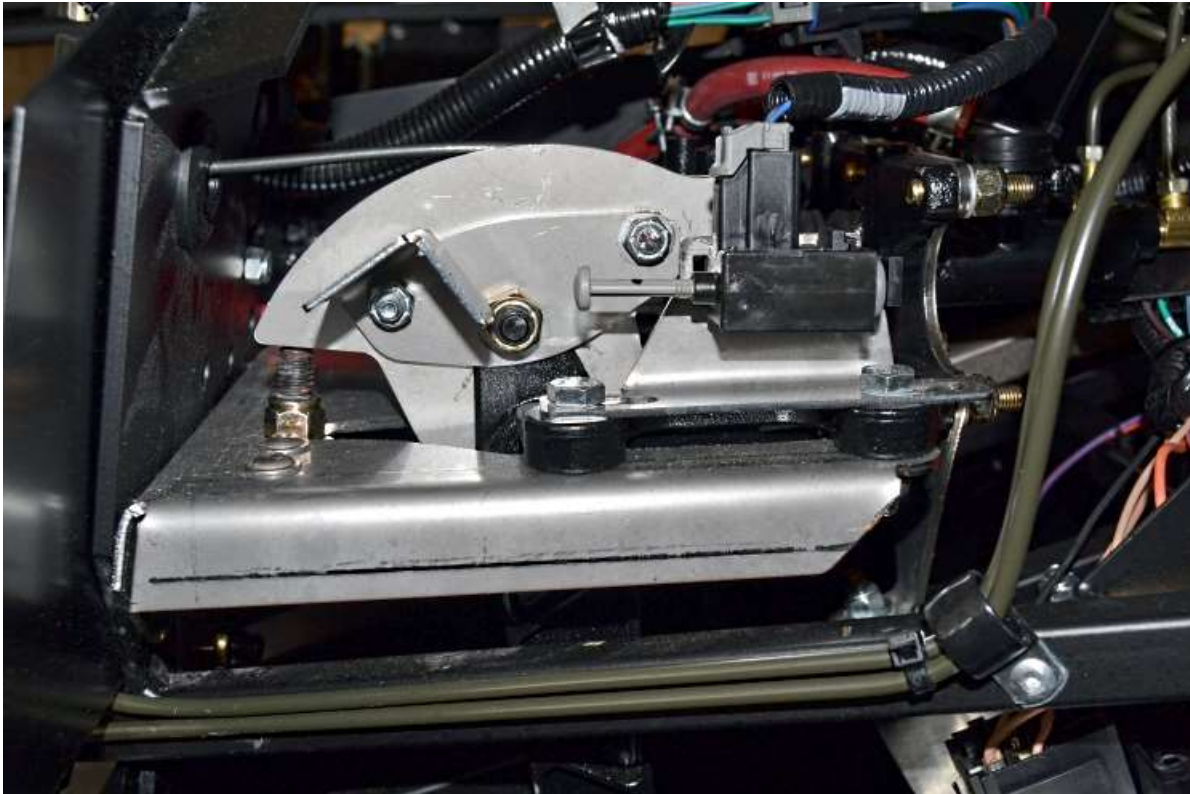

Check the throw of the clutch pedal again carefully. The switch should get pressed in all the way but should not get pushed hard enough to stress/move the body of the switch.

## USING HYDRAULIC CLUTCH

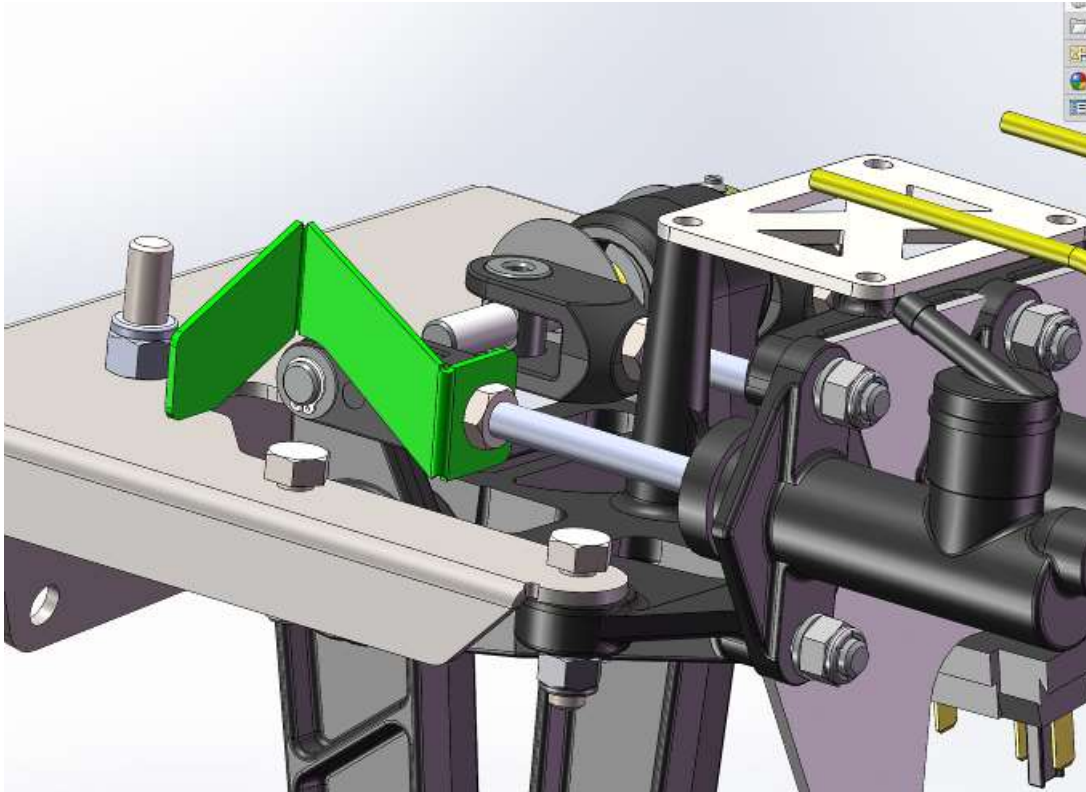

If already installed, unthread the clutch Master cylinder rod from the pedal then place the Hydraulic clutch switch plate on the rod then reinsert the rod into the pedal and tighten the jam nut against the plate.

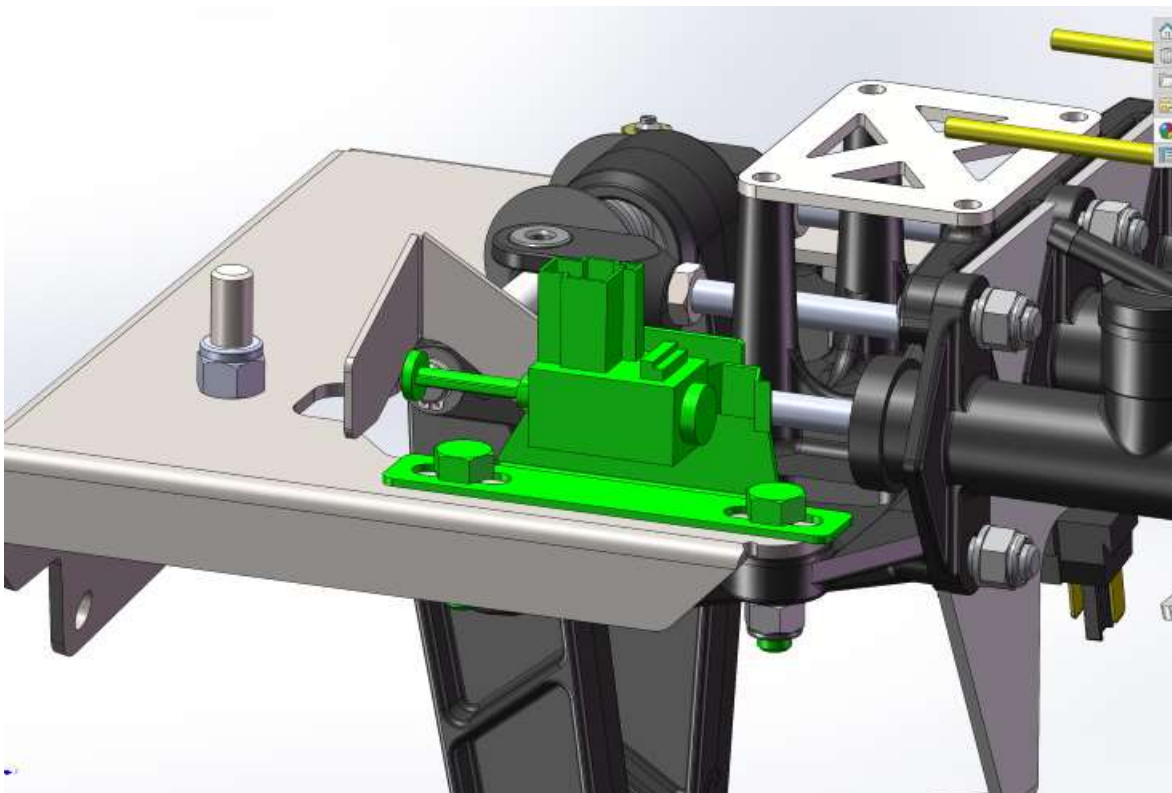

Insert the new  $\frac{5}{16}$ " x 1.25" bolts through the bottom travel switch mount then through the pedal box bracket and pedal box.

Snug the bolts up with a 1/2" wrench and socket so the bottom travel switch bracket can still move.



Have someone push the clutch pedal all the way in then slide the bottom travel switch mount so that the bottom travel switch is pressed in all the way against the switch plate. Hold the switch mount so that it does not move and let the clutch out then tighten the pedalbox mount screws with a 1/2" wrench and socket making sure the switch mount does not move.

Check the throw of the clutch pedal again carefully. The switch should get pressed in all the way but should not get pushed hard enough to stress/move the body of the switch.

## Wiring

### Computer mounting

#### ROADSTER

-  Aluminum computer mounting bracket, 3/16" rivets
-  Drill, 1/4" driver bit, 3/16" drill bit, rivet tool, 1/2" wrench, ratchet, 1/2" socket.



Attach the computer to the aluminum bracket using the 3/16"x 1.25" bolts and nuts provided along with a 1/2" wrench, ratchet, 1/2" socket.



Locate the aluminum computer bracket so that it spans between the upper and lower  $\frac{3}{4}$ " tubes that go down to the front suspension on the right side of the chassis behind the vertical  $\frac{3}{4}$ " tube.

Drill and rivet the bracket to the frame using the  $\frac{3}{16}$ " rivets provided.

## COUPE



The computer can get mounted behind the engine to the 1.50" frame cross tube if the front ground and throttle body wires are extended.

The computer can get mounted after the engine is in place using a 90° drill.

## Harness Prep

### INTERCOOLER WIRE



Cut the red and black Intercooler pump wires back to the Y in the harness. They are not needed or used. Tape the ends separately so they will not ground then tape them to the harness.

### **CAN BUS WIRES**

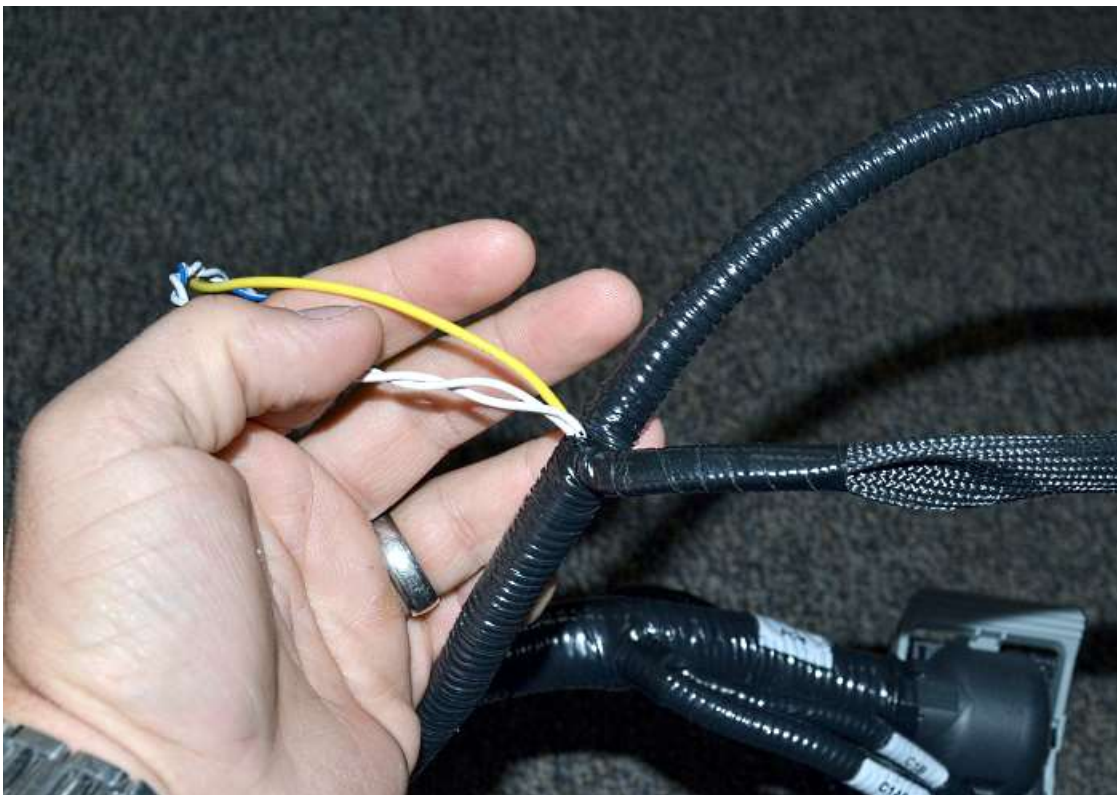

Next to the starter wire, cut the yellow and twisted CAN Bus wires back to the harness. They are not needed or used.

## Harness install

👉 Use the diagram at the beginning of these instructions for general routing and component location.



Use a 2.00" hole saw to cut a hole in the firewall just to the left of the dash support tube with the center 1.50" up from the 2" x 2" tube.



From the engine bay, push the harness leg with the grommet on through the firewall into the cockpit.

In the cockpit, run the wires across to the driver's footbox.



Connect the Accelerator pedal lead (APPS) to the pedal.



Connect the clutch pedal travel switch lead to the switch.



Connect the 6-way connector on the harness to the 6-way connector pigtail with the green wire.

## **ENGINE BAY**



Run the wires to the top of the right footbox. The other holes shown are: Right: rear and sending unit harnesses. Middle: Alternator and starter harnesses.

## FUSE PANEL

### Roadster

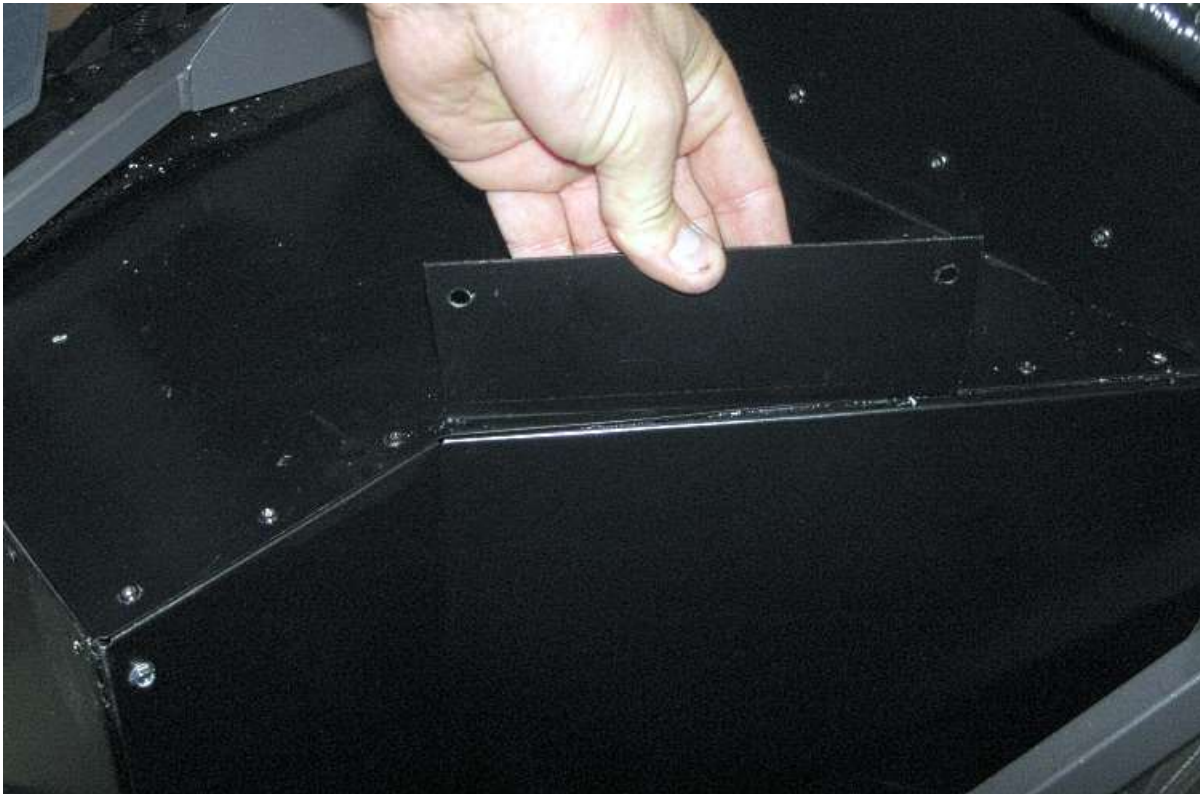

Locate the fuse panel mount (logo on it) and align the front edge with the kink in the right footbox.



Drill  $\frac{3}{16}$ " holes through the footbox and use three of the  $\frac{3}{16}$ " rivets to attach it to the footbox.



Attach the fuse panel to the mounting bracket using a  $\frac{5}{32}$ " hex key,  $\frac{7}{16}$ " wrench,  $\frac{1}{4}$ " washer head screws and locknuts.

## Coupe



The fuse panel can get mounted in the same area as the Roadster.

Drop the Engine and transmission into the chassis.



Note the location of the throttle body wires and ground ring.



Disconnect the ground ring and throttle body wires.



Pull the harness back on itself.

Attach the engine harness plug to the center location on the computer.



Locate the computer on the frame and mark the mounting holes.

Remove the computer, drill and tap the frame for the  $\frac{5}{16}$ "-18 mounting bolts.

Attach the computer to the frame.

Lengthen the 6 wires for the throttle body and ground wires so that they reach back to the correct locations on the engine.

## COMPUTER

### Roadster



Connect the Control pack plug to the computer.



Connect Engine harness plug to the computer.



Connect the 16 pin Engine harness plug to the control pack plug next to the computer.



Run the Alternator/Mass Air long harness leg across to the engine with the engine harness then to the back of the engine.



Run the harness leg across to the left side then to the front of the engine on the left side.

## MASS AIR METER



Plug the mass air meter connector into the mass air meter.

## ALTERNATOR



Run the engine controls alternator plug down to the alternator.



At the back of the engine run the **chassis** harness alternator wire to the left side of the engine.



Run the chassis harness wires under the engine mount to keep them away from the header.

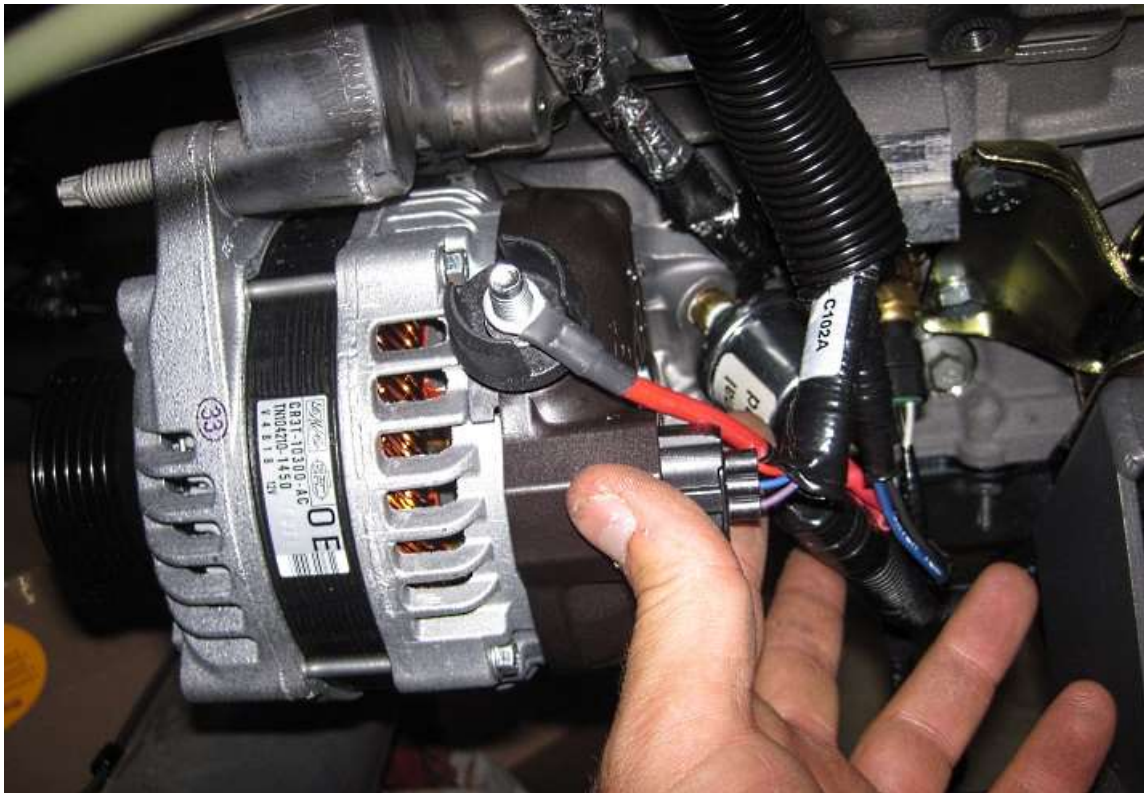

Attach the chassis harness alternator red wire to the post on the alternator.



Attach the engine harness alternator plug to the alternator.

## RADIATOR COOLING FAN

- ✎ It is best to let the engine control the radiator fan. If you do not want to do this, do not use the control pack wires and remove the correct radiator fan fuse from the black box.



From the computer area, run the harness with the orange fan wire forward.

Connect the orange fan wire to the 14ga blue wire included and run it forward to the fan and connect to the blue fan wire.

Ground the black fan wire.

## Battery power



Mount the inline fuse near the fuse panel using  $\frac{3}{16}$ " rivets then run the short battery cable from one side of the inline fuse to the fuse panel stud.



From the other inline fuse stud run a battery cable to the starter battery cable or to a battery cut-off switch.

## Fuel Pump

- 👉 The fuel pump wire is in the Ford Performance 16 pin connector.
- 👉 This set-up allows the engine computer to control the fuel pump instead of the chassis harness but still uses the fuel inertia cut-off switch.

Route the Coyote harness fuel pump green wire to the back of the chassis harness fuse panel.

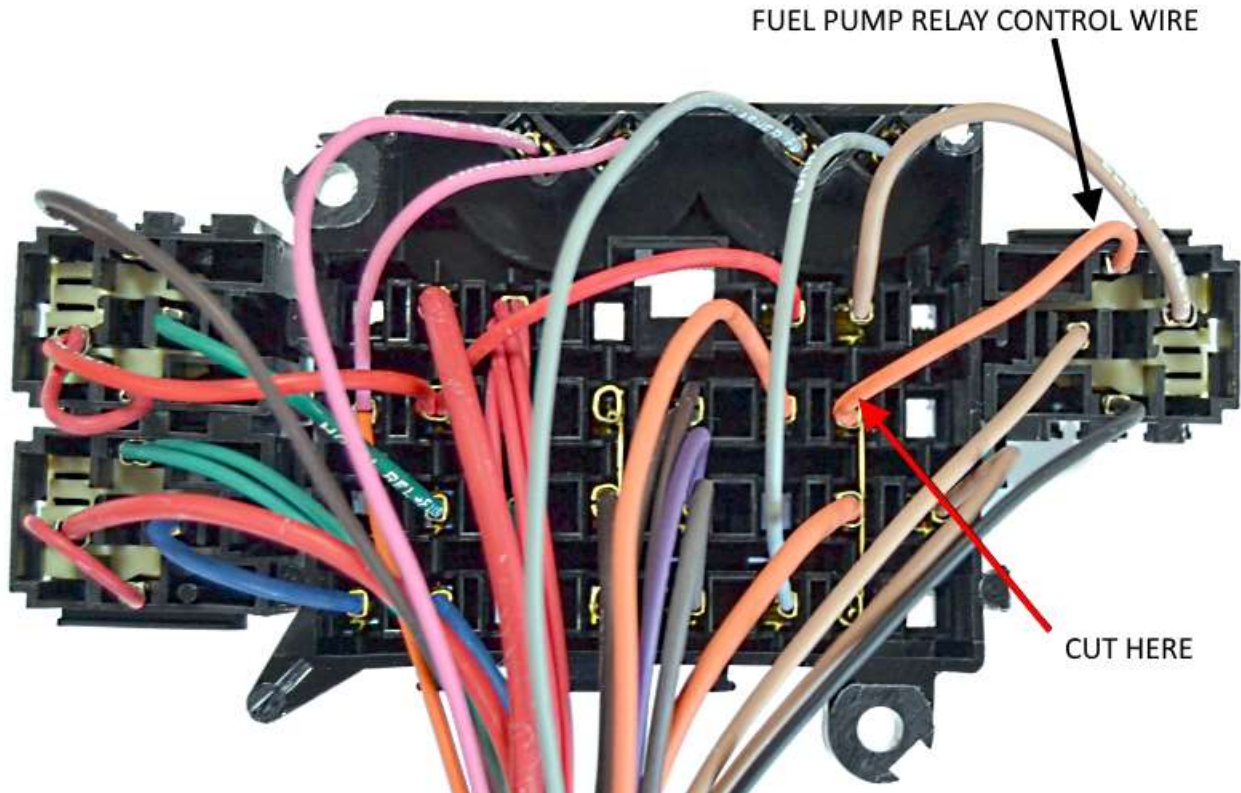

On the chassis harness, cut the small ORANGE jumper wire close to the buss bar that it jumpers from and connect the fuel pump wire from the EFI harness to the orange relay wire. This will use the EFI computer to turn the relay on/off.

The Inertia switch grounds the relay so this wiring still uses the inertia switch. Use a Blue Butt connector or Solder and tape the green wire and Fuel pump relay wires together. Make sure the wires and harness are out of the way of the steering shaft.

## OBD 2 Port



Locate the OBD 2 port on the 2"x 2" tube to the right of the steering wheel.

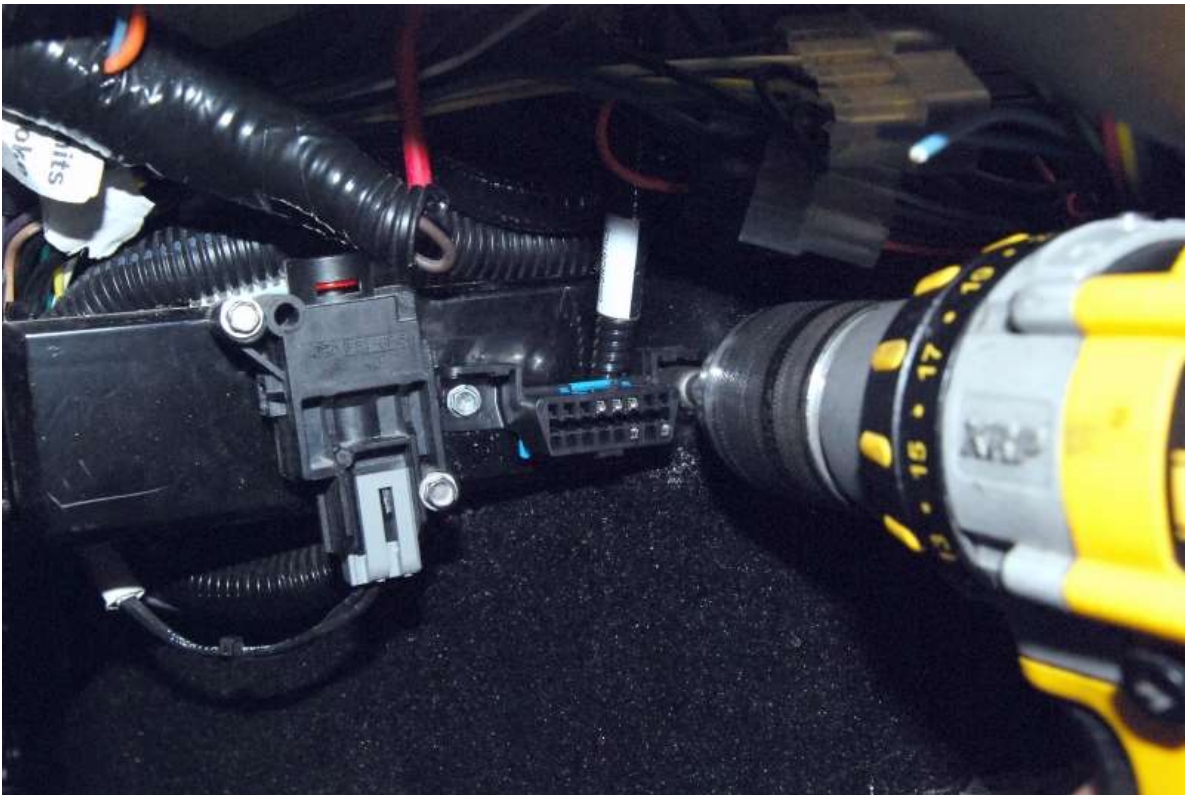

Use some of the aluminum panel #6 screws to attach the OBD 2 plug to the frame.

## Start power

✂ Soldering iron, wire cutters/strippers, electrical tape



Attach a ring connector to the black ground wire and ground it to the chassis.

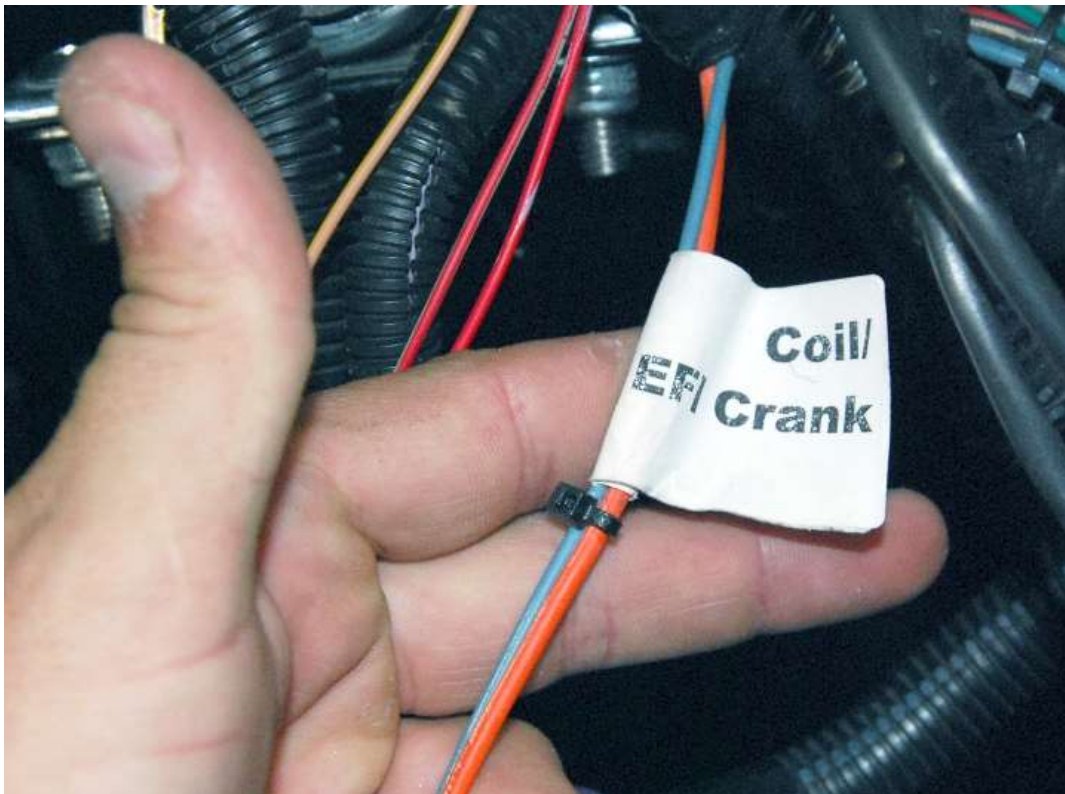

Locate the EFI/crank and coil wires in the chassis harness.

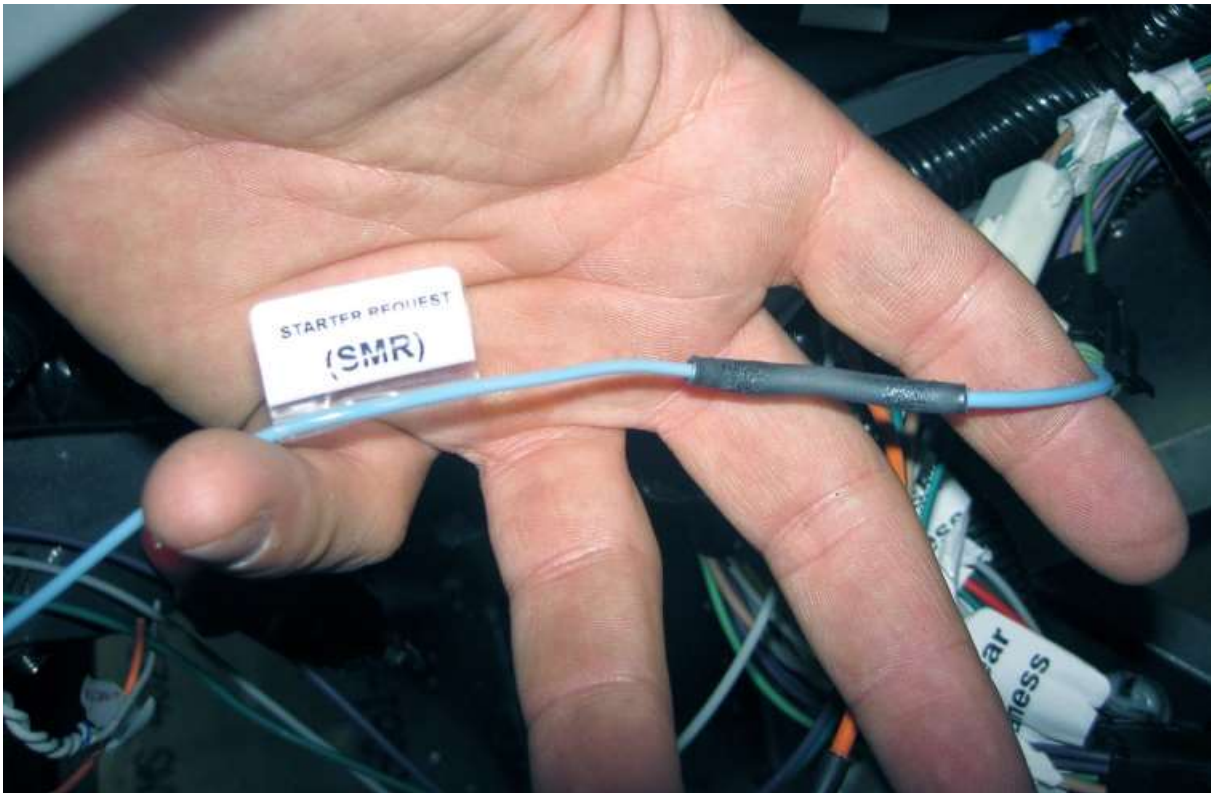

Attach the blue starter wire to the blue EFI wire in the harness using a red butt connector.

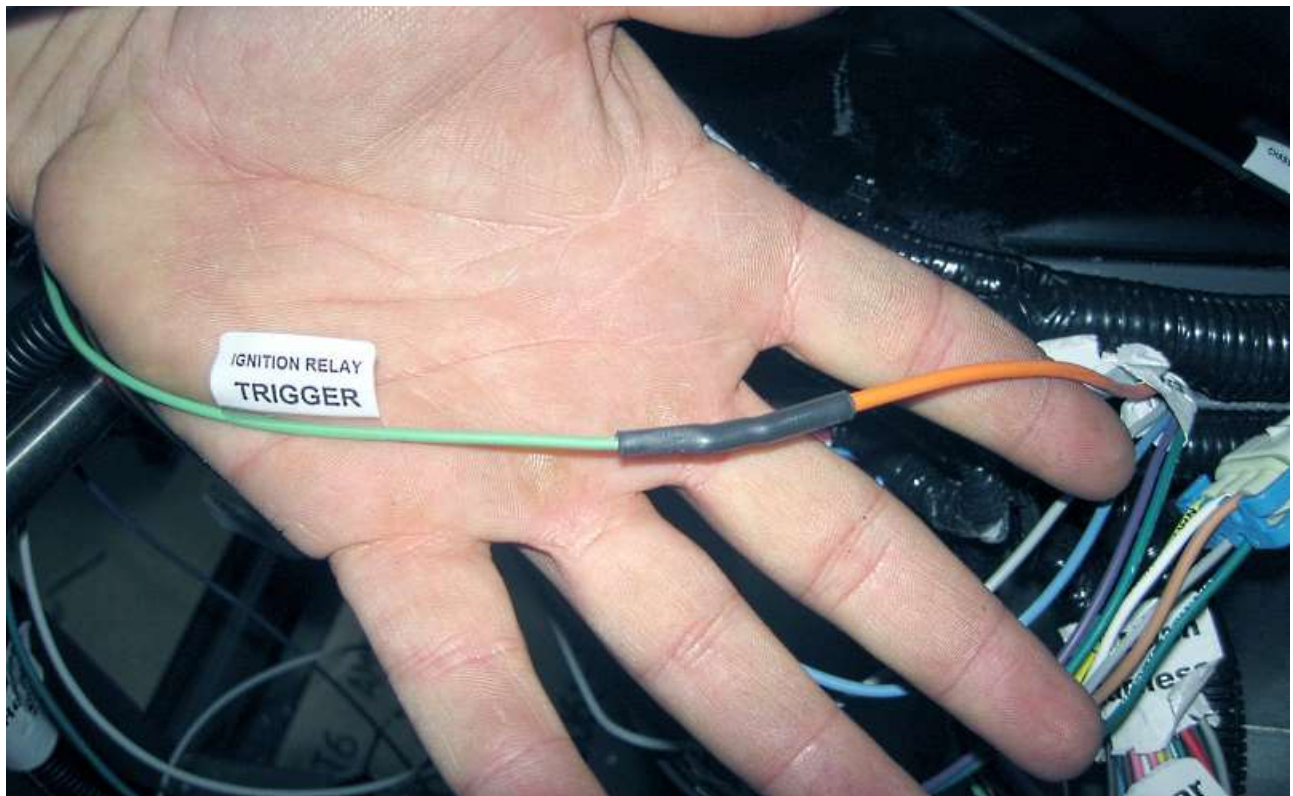

Attach the light green ignition trigger wire to the orange EFI wire in the harness using a red butt connector.

👉 We use the PCM engine starting directions in the Ford Performance instructions. This uses the engine harness starting wire to engage the starter.

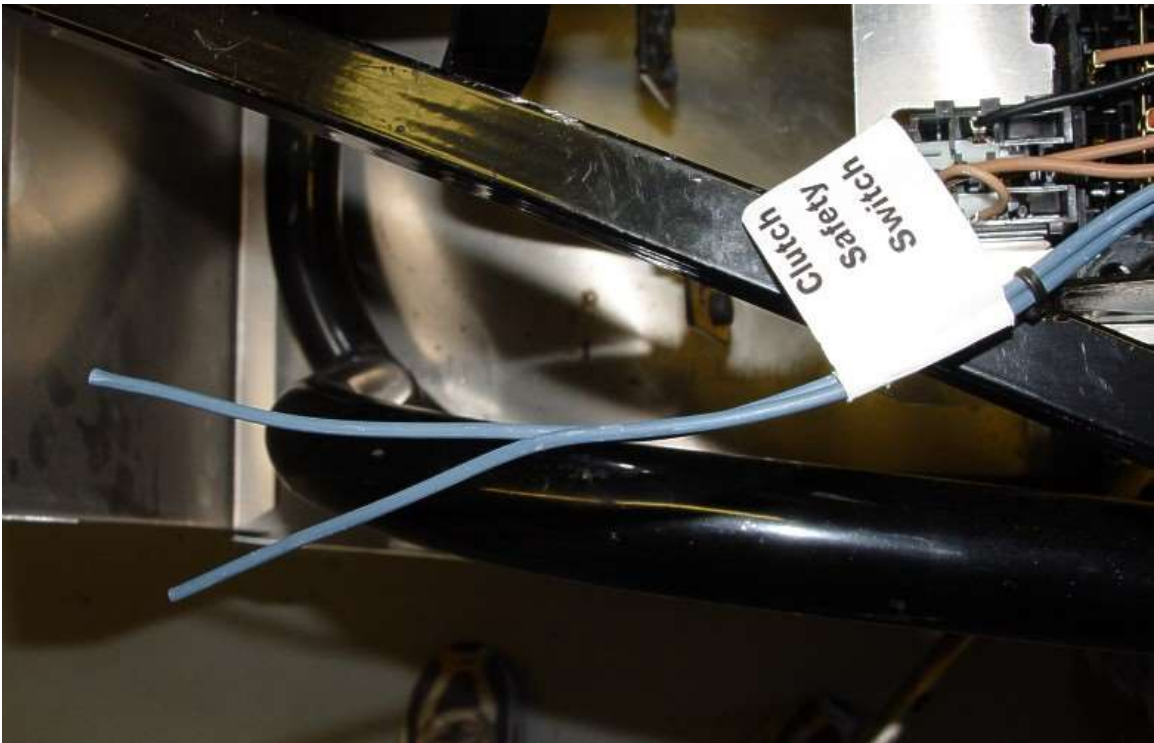

Find the clutch safety switch wires in the left footbox.

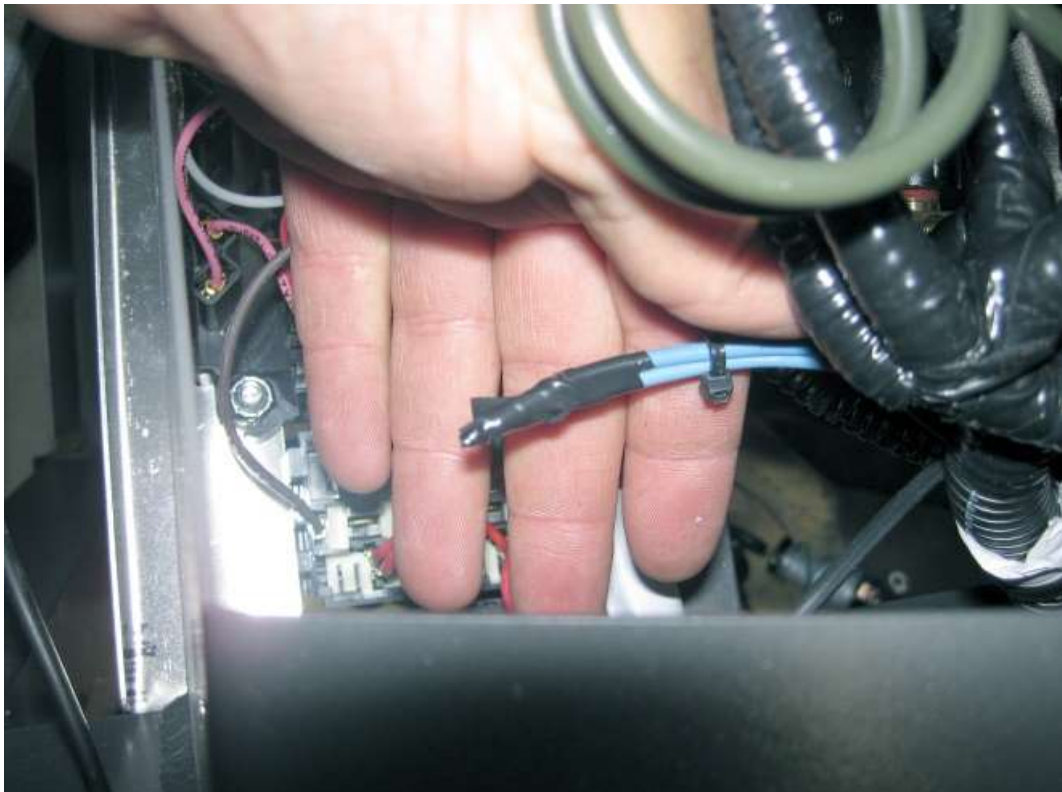

If a neutral safety switch is not going to be used, cut one of the two blue chassis harness wires slightly shorter than the other so the ends do not touch and electrical tape the end.



In the chassis harness on the starter wires leg, cut the blue starter wire end off.



Pull the loom back further down the leg then pull the blue wire out so it does not stick out for the harness and cut it off.



Electrical tape the end to the other wires.

## Tach

- ✂ Soldering iron, wire cutters/strippers, electrical tape.
- 👉 There is no tach wire in the engine harness. The tach will need to get connected to a coil wire.
- 👉 The Tach wiring depends on the gauges being used. If using the Autometer Platinum gauges, they will require a Tach Adapter, FFR# 25284

## AUTOMETER GAUGES

- 👉 The Tach adapter must be hooked up to the main wire feeding all of the coils, not an individual coil

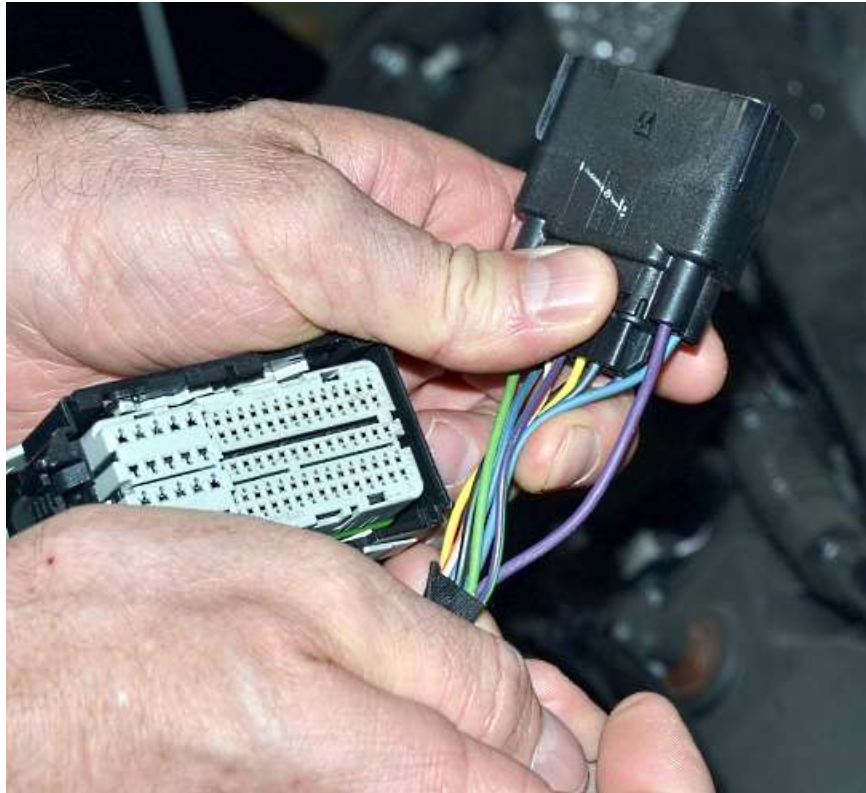

Splice the tach adapter red/green wire to the purple wire in the engine control harness small plug that is on the engine.

Connect the tach adapter red wire to +12v, black wire to ground, and gray wire to the tach.

### **FFR VINTAGE GAUGES**

- ✎ The tach will need to get connected to a coil wire as shown in the gauge instructions according to the Type #3 Coil on plug description.



Run the sending unit harness along the left top side of the engine.



At the #4 cylinder, pull the chassis harness tach wire (purple) out of the harness and remove the tape covering the coil plug wires.



Use a razor knife and wire strippers to remove a short section of the wire insulation on the blue/red wire.



Solder the tach wire to the blue/red wire.

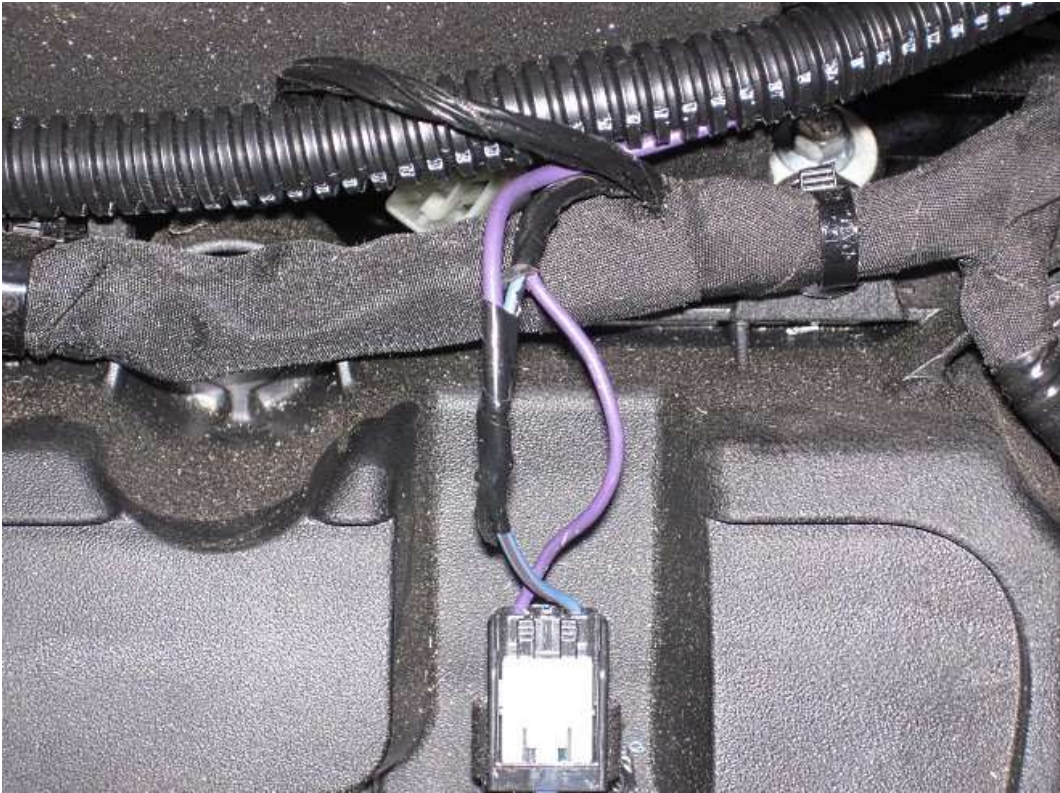

Wrap the connection in electrical tape.



Re-wrap the coil plug wires.

## Oil Pressure and Water temp sensors



Run the chassis sending unit harness to the front left side of the engine.



Use some of the kit 3/4" loom to cover a couple of the smaller looms to declutter the wiring.

Run the wires down the front of the engine to the sending units.



Attach the gauge sensor wires to the correct sensor.

## Clutch cable



Attach the clutch cable to the quadrant and to the clutch fork.

## Exhaust

- ✂ 15mm, 17mm sockets, 15mm wrench
- 🚗 Coyote headers, straight pipes
- 👤 Insert and tighten all of the bolts by hand before tightening any with a wrench.

Attach the headers to the engine.

## O<sub>2</sub> Harness

- ✂ 18mm wrench.
- 🚗 Transmission harness, O<sub>2</sub> sensors
- 👤 The left and right side O<sub>2</sub> sensor wires are different lengths, the long one is for the right side.



Locate the transmission harness bag in the control pack box.

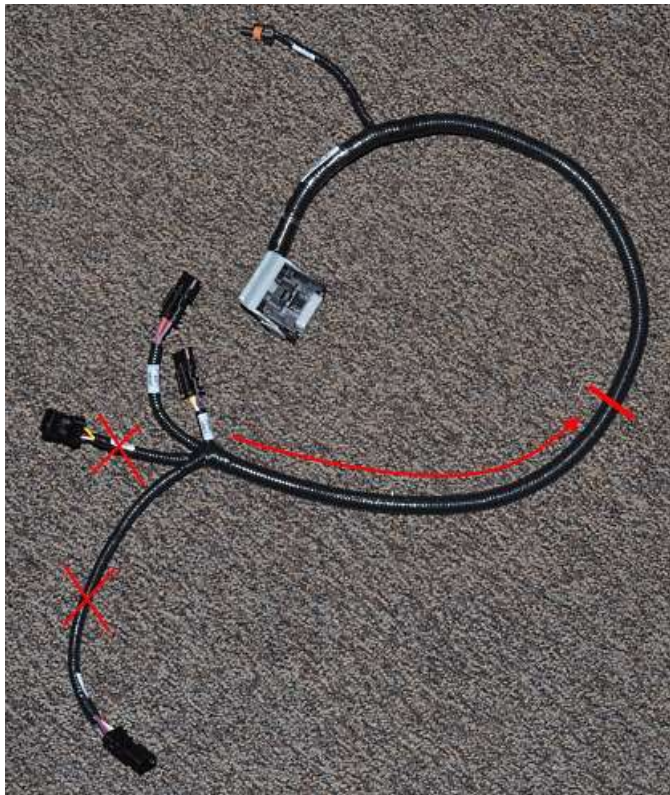

The harness needs to be unwrapped from the end with the four plugs to half way up the length to the computer plug in order to reach both O<sub>2</sub> sensor locations.

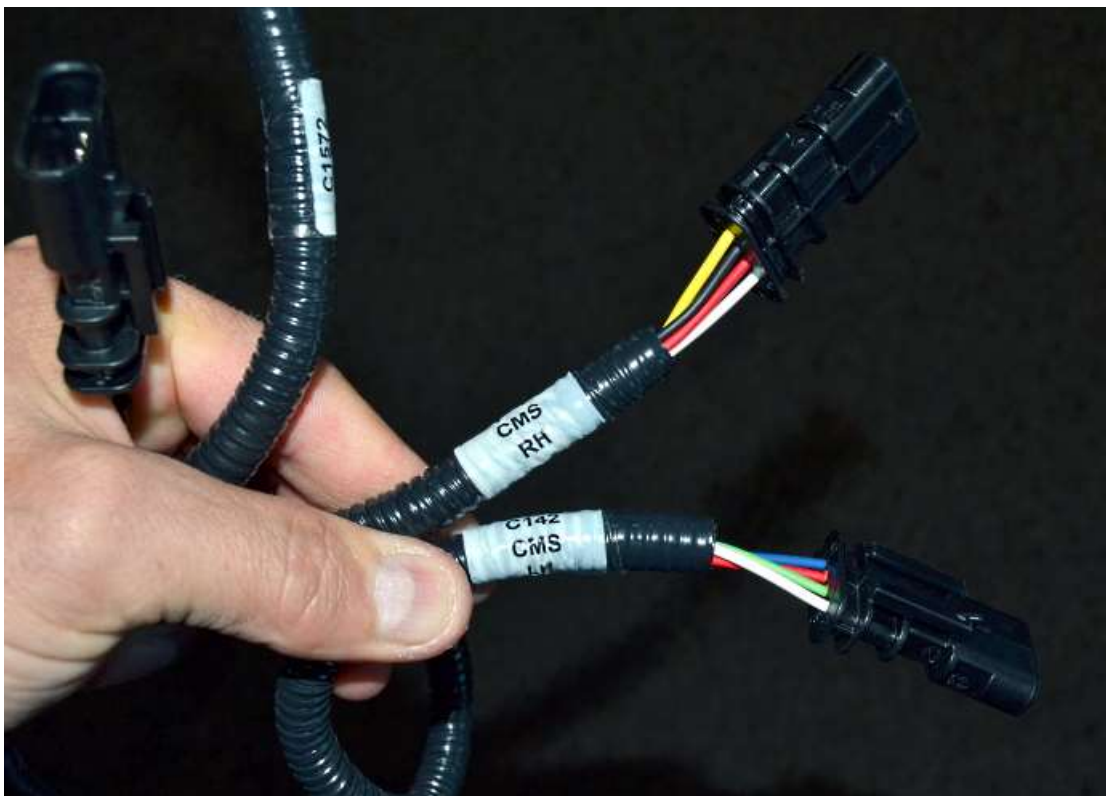

The two CMS 4-wire plugs are not used so the wires can be cut back to where the harness is unwrapped.

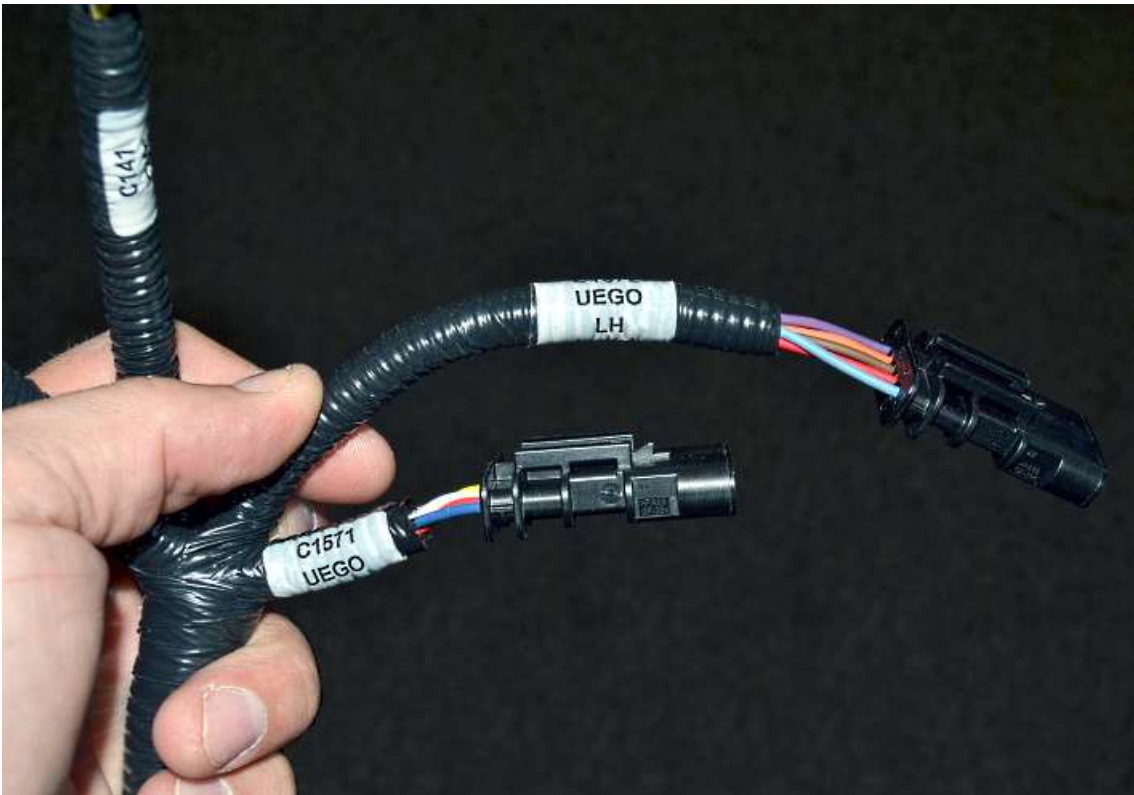

The UEGO 5-wire plugs are the O<sub>2</sub> sensor plugs. Separate these wires out and use some of the kit ½" wire loom to cover the wires up.



Connect the "Transmission" harness plug to the computer.



Connect the single wire connector on the transmission harness to the plug on the engine main harness.



Locate the O<sub>2</sub> sensors in the control pack box.



Screw the O<sub>2</sub> sensors into the exhaust.

Run the left O<sub>2</sub> sensor wires either under or around the engine to the O<sub>2</sub> sensor. Connect the right O<sub>2</sub> sensor wires to the sensor.

## Starting the engine

☞ Oil, Coolant

If not already done, fill the engine with 8 quarts of the correct oil.



If not already done, fill the engine with coolant through an inline filler or radiator cap. To help remove air from the system, remove the top cap until coolant starts going up the tube then recap and hose clamp.

Fill the coolant overflow container.

Set the Fuel pressure regulator to the correct pressure as described in the Ford Performance engine control instructions.

Start the engine and allow the engine to get up to 195°F- 200°F then allow to cool completely, it will suck coolant from the overflow.

- ☞ Cooling fan is switched on at 195°F, turns off at 190°F. This is based on inferred engine coolant temperature. Engine coolant temperature is inferred from the cylinder head temperature. Inferred coolant temperature may not be the same as actual coolant temperature.

Once cool, check the radiator/inline filler neck and coolant overflow container. Top up with coolant if necessary.

- ☞ The ECU has a base tune, it is strongly recommended to have the car dyno tuned after completion.